

OWNER'S MANUAL

XL 390 DIESEL

Land Yacht series

by **Airstream**

TABLE OF CONTENTS

A. WARRANTY AND SERVICE

- Warranty
- Warranty Explanation
- Service
- Reporting Safety Defects
- Maintenance Schedule

B. DRIVING

- Wide Body Limitations
- Loading
- Safety Check List
- Pre-Travel Check List
- Dash Controls & Instruments
- Trailer Towing & Driving Tips

C. CHASSIS

- Engine
- Tires/Wheels
- Air Conditioner/Heater
- Electric Step

D. CAMPING

- Camping Safety
- Smoke Alarm
- Overnight Stop
- Winter Traveling
- Extended Stay
- Slide-Out Room

E. EXTERIOR

- Cleaning
- Roof Ladder and Storage
- Main Door Lock

F. INTERIOR FURNISHINGS & ACCESSORIES

Lounges & Tables
Fabric Care
Features & Fixtures

G. PLUMBING

LP (Liquid Petroleum) Gas
Water System
Water Pump
City Water Hookup
Water Filter
Faucets
Storage and Winterizing
Drainage System
Toilet

H. ELECTRICAL

12 Volt system
TV Antenna
Solar Power
110 Volt System
Generator

I. APPLIANCES

Air Conditioner
Furnace
Refrigerator
Range/Oven
Microwave Oven
Water Heater
Power Roof Vent

J. SPECIFICATIONS

AIRSTREAM, INC.

LIMITED WARRANTY

AIRSTREAM 390/395 DIESEL MOTORHOME

Warranty Coverage

When you buy a new Airstream Motorhome from an authorized Airstream dealer, Airstream, Inc., warrants the motorhome from defects in material and workmanship as follows:

Basic Warranty Period

The warranty is for 15,000 miles (20,000 Kilometers) or one year, whichever comes first, beginning when the vehicle is delivered to the first retail purchaser or first placed into demonstrator service. This warranty must have been started prior to the accumulation of 4,000 miles in order to be valid.

Items Covered

Any part of the motorhome or assembled by the factory is covered by the basic **Airstream Limited Warranty** *except* the following items, which are covered by the individual manufacturers.

Two-year Major Component Warranty

The following major components have two-year warranties provided by their individual manufacturers. Warranty matters will be handled by their respective service points and according to their written policies.

- | | |
|----------------------------|---------------------|
| * Refrigerator | * Power convertor |
| * Range | * Water pump |
| * Furnaces | * Toilet |
| * Water heater | * TV antenna |
| * Microwave | * Stereo |
| * Roof air conditioner | * Tires (pro-rated) |
| * LP tanks | * Awnings |
| * Slide-out room mechanism | * Generator |

This two-year manufacturers' component warranty only applies to vehicles purchased from an authorized dealer, and is only valid to the first retail owner.

Other Individual Manufacturers' Warranties:

The following items are covered by their individual manufacturers' warranties and will be handled by their respective service points and according to their written policy.

- | | |
|------------------|---------------------------------------|
| * Batteries | * Automotive chassis and power plants |
| * Video recorder | * Backing monitor |

These limited warranties do not include failure caused by accident, abuse, normal wear, overload or any cause not attributable to a defect in original material or workmanship of the motorhome or component equipment as installed by the factory.

Limited Structural Warranty

For a period of 24 months or 24,000 miles, whichever comes first, from the date of purchase from an authorized dealer by the first retail purchaser, Airstream warrants the motorhome to be free from substantial structural defects in materials and workmanship.

For the purposes of clarity, "Structural" shall be limited to the structure of the sidewalls, front and back walls, roof and floor.

All other stipulations in the Basic Airstream Limited Warranty shall apply.

Limitation of Implied Warranties

All warranties of merchantability and fitness for a particular purpose, whether written or oral, express or implied, shall extend only for a period of one year from the date of original purchase, or 15,000 miles, whichever comes first. There are no other warranties which extend beyond those described on the face hereof and which expressly excludes conditions resulting from normal wear, accident, abuse, exposure or overload. Some states do not allow limitation on how long an implied warranty lasts, so the limitation may not apply to you.

Airstream's Responsibility

The basic **Airstream Limited Warranty** applies for a period of one year from the date of original purchase, or 15,000 miles, whichever comes first, and the application date of all warranties is that indicated on the owner's identification card. Defects in items covered under this warranty will be corrected without cost upon the return, at the owner's expense, of the motorhome or defective part to an authorized Airstream dealer.

Care and Maintenance

This warranty covers only defective material and/or workmanship; adjustments and checking are excluded. All adjustments are made at the factory prior to shipment, and rechecked by the dealer prior to delivery to the customer. Adjustments thereafter become a customer responsibility.

The owner is also responsible for following all recommendations, instructions and precautions contained in the Airstream Owner's Manual and the individual manuals furnished by the chassis, appliance and other manufacturers.

Installations not Covered

Airstream, Inc., does not accept any responsibility in connection with any of its motorhomes for additional equipment or accessories installed at any dealership or other place of business, or by any other party. Such installation of equipment or accessories by any other party will not be covered by the terms of this warranty.

If Repairs are Needed

If your motorhome needs repairs under the terms of the Airstream Limited Warranty, you should:

1. Take your motorhome to your selling dealer or other Authorized Airstream dealer.
2. If the dealer is incapable of making the repair, request that he contact the Service Administration Department at Airstream, Inc., for technical assistance.

3. If repairs are still not made, the customer should contact Airstream, Inc., 419 W. Pike Street, Jackson Center, Ohio 45334, Attention: Owner Relations Department, and furnish the following information.
 - * The complete serial number of the motorhome
 - * Mileage
 - * Date of original purchase
 - * Selling dealer
 - * Nature of service problem and steps or service which have been performed. (The owner may be directed to another dealer at the owner's expense.)
4. If, after taking the above steps, repairs are still not complete, the Airstream owner may request the motorhome be allowed to be brought to the Factory Service Center at the owner's expense.

Dealer Representation Excluded

The full extent of Airstream's Limited Warranty is set forth in detail in the warranty folder, and in the Explanation of Airstream Limited Warranty covered in the Airstream Motorhome Owner's Manual. Airstream, Inc., will not be responsible for additional representations or implied warranties made by any of its dealers to the extent those representations are not a part of, or are contrary to, the terms and conditions of the Airstream Limited Warranty.

Consequential and Incidental Damages

Airstream, Inc., will not be responsible for any consequential or incidental expenses or damages resulting from a defect. Incidental expenses include, but are not limited to, travel expenses, gasoline, oil, lodging, meals, telephone tolls, loss of work and loss of use of the motorhome. Some examples of consequential damages would be: stained curtains due to rain leaks or delaminated floor caused by a plumbing leak. *Some states do not allow the exclusion or limitation of incidental or consequential damages, so the above limitation or exclusion may not apply to you.*

Warranty Transfer

The basic **Airstream Limited Warranty** is transferable to subsequent owners for the duration of the warranty period. Warranty transfer application forms are available from your dealer or Airstream, Inc., Service Administration Department.

Changes in Design

Airstream, Inc., reserves the right to make changes in design and improvements upon its product without imposing any obligation upon itself to install the same upon its products theretofore manufactured.

This warranty gives you specific legal rights, and you may also have other rights which vary from state to state.

Thor Industries
Airstream, Inc.
419 West Pike
Jackson Center, Ohio 45334
(937) 596-6111

WARRANTY EXPLANATION

Along with your new Airstream motorhome you have purchased the Airstream Limited Warranty. Read your Limited Warranty carefully. It contains the entire agreement with respect to Airstream's obligation on the Limited Warranty on your new vehicle. The terms of the Limited Warranty, and only those terms, will define Airstream's responsibility. When you receive your Limited Warranty file it for safekeeping.

Upon proof of purchase date to any Airstream Dealer Service Center, defects in materials or workmanship will be repaired or replaced without cost to the owner for a period of twelve (12) months from the original purchase date, or 15,000 miles, whichever occurs first. Written warranties of some manufacturers of components of the motorhome will be honored by Airstream for the duration on that manufacturer's warranty.

Items such as motorhome chassis, engine, tires, batteries and generator are serviced by their respective manufacturers and will be handled by their service centers according to the terms of their written policy. Any warranty forms from these manufacturers should be completed promptly, preferably at time of purchase.

Your motorhome chassis is prechecked by its manufacturer before delivery to Airstream. All service to the chassis must be performed by the manufacturer according to the manufacturer's warranty and service policies. Literature is supplied with each Airstream motorhome which gives important information concerning its warranty coverage; however, the Airstream Limited Warranty covers the chassis heater, defrosters, windshield wiper blade, motor, washer, LP gas bottle and gas regulator.

Paint and appearance items which show imperfections should be brought to the attention of your dealer at the time of delivery and during pre-delivery inspection. Normal deterioration by use and exposure is not covered by the Airstream Limited Warranty.

Damage to enameled or porcelain surfaces resulting from abrasion, collision or impact, and broken window glass is not covered by the Airstream Limited Warranty.

The Airstream Limited Warranty Excludes:

Normal Wear:

Items such as water purifier packs, curtains, upholstery, floor coverings, window, door and vent seals may show wear within the one year Limited Warranty period depending upon the amount of usage, weather and atmospheric conditions.

Accident

Damage caused by accident is usually visible, and we strongly urge our dealers and customers to inspect the motorhome upon delivery for any damage caused by accident while being delivered to the dealer, or while it is on the dealer's lot. Damage of this nature becomes the dealer's or your responsibility upon acceptance of the motorhome. GLASS BREAKAGE, whether obviously struck or mysterious, is always accidental and covered by most insurance policies.

Abuse

Lack of customer care and/or improper maintenance, including failure to comply with the terms of the Owner's Manual, or failure to heed proper vehicle operation shown by the dash instruments are not covered by warranty.

Exposure

Deterioration by sunlight is possible to such items as tires, curtains or upholstery. Steel or metal surfaces are subject to the elements, causing rust and corrosion which is normal and beyond the control and responsibility of Airstream.

Overload

Damage due to loading beyond capacity or to cause improper balance is not covered by the Airstream Limited Warranty. The Airstream motorhome body is engineered to properly handle any normal load. There are limits to the amount of load that can be safely transported depending upon speed and road conditions. If these limits have been exceeded the Airstream Limited Warranty will not cover resulting damage. For additional information on the load capacity of your motorhome consult your Owner's Manual or gross vehicle weight rating plate. The motorhome alignment is checked during the last quality inspection. These tolerances will only change if the motorhome is subjected to abuse, such as dropping off a sharp berm, striking a curb, or hitting a deep hole in the road. Such damage would be considered as resulting from an accident which risks are not covered under the warranty. Abnormal tire wear and/or wheel alignment resulting from such damage is not covered under the terms of the warranty.

Automotive chassis manufacturers recommend the owner have the alignment redone after the coach has made a couple of trips and a "normal load" determined. This allows the alignment to be set for your particular usage pattern.

SERVICE

The Airstream Silver Key Delivery Program is an exclusive Airstream program. Before leaving the factory each and every vital part of the motorhome is tested for performance. Each test is signed and certified by an inspector. After the motorhome arrives on your dealer's lot all of these vital parts and systems are again tested. When you take delivery of your new motorhome you will receive a complete checkout.

Please contact your dealer if you need service. Major service under your Airstream Limited Warranty is available through our nationwide network of Airstream Dealer Service Centers. An up-to-date list of Dealer Service Centers has been provided with your new motorhome. This list is current as of the date of publication.

Occasionally dealerships change, or new dealers are added who may not appear on this list. For this reason, it is suggested that you contact your local dealer from time to time and bring your list up to date. He can also provide you with additional copies if you need them.

ALL CENTERS OPERATE ON AN APPOINTMENT BASIS FOR THE UTMOST EFFICIENCY.

When you require service from the Airstream Factory Service Center or a Certified Dealer Service Center please contact the service manager for an appointment, and kindly inform him if you are unable to keep the appointment date or wish to change it.

Service may be arranged at the Factory Service Center by contacting the Service Coordinator at:

Airstream Factory
Service Center
419 W. Pike Street
Jackson Center, Ohio 45334
Phone: 937-596-6111

You Should Also be Aware of the Following:

Airstream is not responsible for any consequential or incidental damages incurred as a result of any defect. Consequential damages include, but are not limited to, travel expenses, gasoline, oil, lodging, meals, telephone tolls, loss of work and loss of use of the motorhome.

In the event of a defect, the owner must take all reasonable corrective action to lessen the damages which might result from such defect. Airstream will not be responsible for damages which could have been avoided.

Airstream's responsibility is defined solely by the Airstream Limited Warranty and Airstream is not responsible for or bound by representations or warranties made by any of its dealers.

Your Airstream Limited Warranty is transferable to subsequent owners of the motorhome, but only for the duration of the warranty period. Warranty transfer application forms are available from your dealer or the Airstream factory.

REPORTING SAFETY DEFECTS

If you believe that your vehicle has a defect which could cause a crash or could cause injury or death, you should immediately inform the National Highway Traffic Safety Administration (NHTSA) in addition to notifying Airstream, Inc.

If NHTSA receives similar complaints, it may open an investigation, and if it finds that a safety defect exists in a group of vehicles, it may order a recall and remedy campaign. However, NHTSA cannot become involved in individual problems between you, your dealer, or Airstream, Inc.

To contact NHTSA, you may either call the Auto Safety Hotline toll-free at 1-800-424-9393 (or 202-366-0123 in Washington, D.C. area) or write to: NHTSA, U.S. Department of Transportation, Washington, D.C. 20590. You can also obtain other information about motor vehicle safety from the Hotline.

MAINTENANCE SCHEDULE

Note: See Freightliner and appliance manufacturer's literature for further information.

EVERY 1000 MILES OR 30 DAYS

Escape Window	Check operation of latches and upper hinge
Battery (lead-acid)	Check water level
Smoke Alarm	Test and replace battery as required
G FI Circuit Breaker	Test and record

EVERY 5000 MILES OR 90 DAYS

Exterior Door locks	Lubricate with dry graphite
Exterior Hinges	Lubricate with light household oil
LPG Regulator	Check bottom vent for obstructions
Main Door Striker Pocket	Coat with paraffin
Range Exhaust Hood	Clean fan blades and wash filter
Roof Vent Elevator Screws	Lubricate with light household oil
Main Door Step	Lubricate moving parts and check

EVERY 10,000 MILES OR 6 MONTHS

Exterior	Clean and wax
Hitch	Check bolts and welds (90 ft. lb.)

EVERY YEAR OR 12,000 MILES

Battery	Clean, neutralize and coat terminals with petroleum jelly
LP Tank	Have purged by LP supplier
Seams	Check seal on exterior seams, windows, lights, and vents. Reseal with Kool Seal or equivalent as needed.

MAINTENANCE RECORDS

Date	Dealer	Service Performed

DRIVING

WIDE BODY LIMITATIONS

Vehicles with overall body width greater than 96" are known as "wide bodies." Wide body vehicles are restricted to use on main highways in certain states. A vast majority of states allow 102" body width on all highways, but wide body width is now allowed on all federal highways in the United States. Your dealer may be able to furnish more specific information. If you are concerned about vehicle width, we invite you to consider other fine Thor vehicles offered in the standard 96" width.

LOADING

Below is a sample of the weight information chart provided in all Airstream vehicles. This information can be found in your vehicle on the back of the first wardrobe door on the curbside of the vehicle about 60" up from the floor or in one of the galley overhead lockers.

MOTORHOME WEIGHT INFORMATION:

CONSULT OWNER'S MANUAL FOR SPECIFIC WEIGHING
INSTRUCTIONS AND TOWING GUIDELINES.

MODEL		GVWR
UVW	NCC	GCWR

THIS MOTORHOME IS CAPABLE OF CARRYING UP TO GAL
OF FRESH WATER (INCLUDING WATER HEATER) FOR A TOTAL OF LBS.

REFERENCE: WEIGHT OF FRESH WATER IS 8.334 LBS/GAL; WEIGHT OF LP GAS IS
4.5 LBS/GAL (AVERAGE).

- GVWR** **GROSS VEHICLE WEIGHT RATING** means the maximum permissible weight of this motorhome. The GVWR is equal to or greater than the sum of the unloaded vehicle weight plus the net carrying capacity.
- UVW** **UNLOADED VEHICLE WEIGHT** means the weight of this motorhome as built at the factory with full fuel, engine oil, and coolants. The UVW does not include cargo, fresh water, LP gas, occupants, or dealer installed accessories.
- NCC** **NET CARRYING CAPACITY** means the maximum weight of all occupants including the driver, personal belongings, food, fresh water, LP gas, tools, tongue weight of towed vehicle, dealer installed accessories, etc., that can be carried by this motorhome, (NCC is equal to or less than GVWR minus UVW).
- GCWR** **GROSS COMBINATION WEIGHT RATING** means the value specified by the motorhome manufacturer as the maximum allowable loaded weight of this motorhome with its towed trailer or towed vehicle.

***WARNING - Do not exceed the hitch capacity of 500 load and 5000 lb. tow.**

The motorhomes have large fluid tanks and lots of storage areas. It gives you great flexibility in loading. With flexibility comes responsibility. If you want to load down all the storage compartments the amount of fluids will have to be reduced.

Do you really want to carry 750 pounds of water to a RV park 1,000 miles away and then hook up to a city water supply anyhow? Even if you're going to the "boondocks" you can usually fill your water tank shortly before entering the area. Just reducing your load by 10 gallons of water lets you carry an awful lot of fishing and camping gear.

SAFETY CHECK LIST

Your Airstream motorhome should be given a thorough safety check before a trip. Regular use of the following list will provide safe operation of your motorhome and will help you spot any malfunctioning equipment and correct the problem as soon as possible.

FAILURE TO HEED MANY OF THE FOLLOWING ITEMS MAY CAUSE DAMAGE TO THE VEHICLE OR PERSONAL INJURY.

EXTERIOR CHECK LIST (BEFORE ENTERING VEHICLE)

1. Check condition of tires for proper inflation.
2. Turn off LPG valve on LPG tank.
3. Check that sewer connection, all external compartments and filler openings are properly stowed or closed and/or locked.
4. Check that items stored on exterior of vehicle are securely tied down.
5. Would any items stored on exterior of vehicle present a clearance problem?
6. Lower and secure awnings/TV antenna.

INTERIOR CHECK LIST (BEFORE DRIVING OFF)

1. It is important that the main door be completely closed and locked during travel. This includes locking the dead bolt.
2. Turn off living area water pump.
3. Check that refrigerator door is fastened.
4. Check that nothing heavy is stored in overhead or high cabinets which could fall out and cause injury. Heavy items should be stored in low cabinets.
5. Stow folding and pedestal tables.
6. Check that counter tops, range top, credenza tops and shelves are clear of even small items that could become projectiles in an accident.
7. Do not cook while under way. Hot food or liquid could scald due to a sudden stop or accident.
8. Check that any internal stowage is securely held in place.
9. Check that lights and switches are set in positions safe for travel.
10. Adjust the driver's seat so that you can easily reach and operate all controls. Make sure seat is locked in position. Do not adjust driver's seat swivel or fore and aft mechanism while vehicle is moving. The seat could move unexpectedly causing loss of control.
11. Check that front passenger's seat is locked in position - both fore and aft adjustment and swivel mechanism.
12. Check rear view mirror adjustment, inside and outside. Adjust curtains if applicable for maximum visibility.
13. Fasten seat belts.
14. Check that step light goes out and that electric step has retracted.

SAFETY SEAT BELTS

In the forward driver's area of the motorhome, safety seat belts are provided for the use of the driver and the right front passenger. Safety belts are available for other seats. It is strongly recommended that all occupants remain seated with their safety belts firmly attached while the motorhome is in motion. The driver should adjust his seat so that he is able to reach all controls easily with the belt on, especially able to use all the travel on the foot brake. The belt should be placed as low as possible around the hips to prevent sliding out from under them in case of accident. This places the load of the body on the strong hip bone structure instead of around the soft abdominal area. Two people should never try to use the same seat belt.

WARNING: Children must be secured in a Federally Approved Child Restraint Device. Failure to use proper restraints can result in severe or fatal injuries in case of accidents.

Child restraint devices are designed to be secured with lap or lap/shoulder belts. All instructions supplied by the restraint manufacturer must be followed. Statistics have shown children are safer when properly restrained in a rear seating position than in a front seating position.

Often the children travelling in motorhomes are grandchildren. There are times when our love for grandchildren makes us hesitate to properly supervise their actions. Don't hesitate when it comes to their safety. Make sure they are properly restrained.

CHILDREN HAVE LOVED ONES TOO...IF YOU WON'T BUCKLE UP FOR YOURSELF, BUCKLE UP FOR THEM.

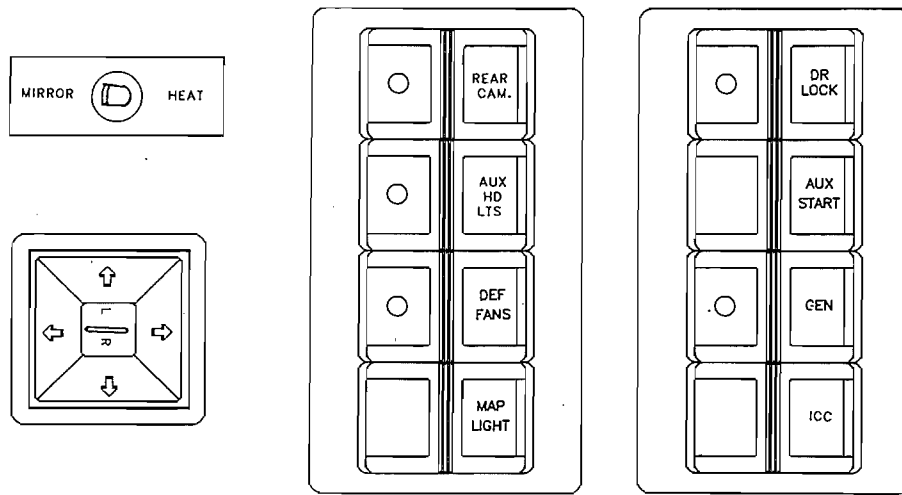

NOTE: Switches will vary according to options on vehicle.

AIRSTREAM DASH CONTROLS

Most automotive gauges and controls are standard instruments provided by the chassis manufacturer. Their function and use is described in your Drivers Manual. The exception on automotive controls is the heater/air conditioner. Operating instructions on these components can be found in the chassis section of this manual.

ARM REST SWITCHES:

- **Door Lock** - The main door can be locked or unlocked from the drivers seat. Remember to hide an extra door key on the exterior in case of unexpected battery failure.
- **Auxiliary Start** - The auxiliary start switch is intended to be used if the engine battery becomes too discharged to turn the engine over. To operate, hold the switch in the start position, then use the ignition switch in a normal fashion. Operating the auxiliary start switch closes the points on a large solenoid, tying all three vehicle batteries together for increased starting power.
- **Generator Switch** - The remote generator switch on the dash allows the driver to start or stop the generator without leaving the driver's seat. It should be noted a built-in time delay allows the generator to reach full operating speed before 120 volt current is provided to the coach.
- **ICC Blink** - With this switch it is possible to blink the clearance lights on the motorhome. It's most commonly used as a way of indicating your thanks for a courtesy shown to you by another driver.
- **Rear Camera** - The rear view monitoring camera has two positions. One will show the rear bumper and operating the switch tilts the camera to view further back.
- **Driving Lights** - To operate the driving lights the regular head lights must be turned on first.
- **Defrost Fans** - In cool, damp weather these fans really help to clear the large windshields. This switch turns them on and off and each fan has it's own switch to operate the oscillating feature.
- **Map Light** - If you leave the switch at the overhead map light in the on position the light can then be controlled by this arm rest switch.
- **Mirror** - Move center switch to R or L. The four perimeter switches will then move the right or left mirror in the direction indicated. The paddle type switch marked heat is for defrosting the mirrors. (Hopefully you won't need this unless you're a skier).

POWER SEAT CONTROLS

Besides the normal power seat switch there are two additional finger levers. One allows the seat to recline and the other will allow the seat to rotate.

WARNING: Never adjust drivers seat while vehicle is in motion.

CAUTION: Revolving the power seat completely around will pull the wiring apart. The seats should only be swivelled toward the center of the vehicle. If the wires are loosened they can be reconnected by following the color code: Red to red, green to green, etc. On some models the wires will be on a plug that can be reattached.

CAUTION: Make sure the drivers seat will clear the slide-out room before retracting the room.

TRAILER TOWING AND DRIVING TIPS

Since this vehicle is designed and intended to be used primarily as a load carrying vehicle, towing a trailer will affect handling, durability and economy. Maximum safety and satisfaction depends upon proper use of correct equipment and avoiding overloads and other abusive operation.

CAUTION:

The maximum loaded trailer weight which you can pull with your vehicle is 5,000 lbs. Vehicles should be properly equipped for towing trailers. Information on trailer hauling capabilities and special equipment required may be obtained from your Airstream dealer.

To assist in attaining good handling of the vehicle/trailer combination it is important that the trailer tongue load be maintained at approximately 10% of the loaded trailer weight, but not to exceed 550 lbs. Tongue loads can be adjusted by proper distribution of the load in the trailer, and can be checked by weighing separately the loaded trailer and then the tongue.

When towing trailers, tires should be inflated to the highest pressures shown on the information plate attached to the drivers door jamb or dash of your motorhome. The allowable passenger and cargo load (GVW) of this vehicle is reduced by an amount equal to the trailer tongue load on the trailer hitch.

Trailer brakes are required on axles of trailers over 1,000 lbs. loaded weight.

CAUTION:

If your Freightliner chassis requires towing please refer to their manual for directions. The may be called at 1-864-487-1700.

NOTES

CHASSIS

The Airstream motorhome is built on a Freightliner chassis. Operation of the engine and other related components is discussed in the Owners and Drivers Manual supplied with each coach.

If repairs are needed it can be difficult to determine which parts of the chassis are warranted by Freightliner, and which are Airstream's responsibility. The following list shows the major components of the chassis and the company responsible for their servicing.

FREIGHTLINER X LINE CHASSIS

Engine	Air Conditioner Compressor
Transmission	Shocks
Brakes	Automotive Fuse Panels
Steering Assembly	Parking Brake
Front Spindle, Bearings	Fuel Tank
Alternator	Cruise Control
Turn Signals	Wheels
Drive Axle and Hubs	

AIRSTREAM

Auxiliary Heater	Windshield Wipers
Dash Air Conditioner/Heater	Isolator

The above list covers almost all of the chassis components. If you need further clarification or information your dealer should be contacted with the details.

ENGINE ACCESS

Although most engine functions and maintenance can be performed from outside the coach, occasionally "top" engine service will be required.

To make this servicing easier the bed top can be raised with the assistance of gas props. Once raised, a safety prop, clipped to the side of the bed should be used to prevent the heavy bed from accidentally lowering unexpectedly.

WARNING - The lifting and supporting strength of the gas props vary according to temperature. Props that support the bed top when hot may let the bed close rapidly when cold.

TIRE SUPPORT

Since motorhomes may sit for long periods of time it is important to properly support the tires if blocks are used for leveling.

The following information is provided by the Michelin Technical Group.

Extreme caution must be taken to ensure that the tires are fully supported when using blocks to level motorhomes and/or RV's. The load on the tire should be evenly distributed on the block and in the case of duals, evenly distributed on blocks for both tires. If not properly done, the steel cables in the sidewall of the tires may be damaged and could lead to premature fatigue of the sidewall.

The **CORRECT** methods are shown in Figure 1. Please note that the blocks are wider than the tread and longer than the tire's footprint. This provides maximum support to the tires and assures that the load is evenly distributed throughout the tire's footprint area.

FIGURE 1
CORRECT

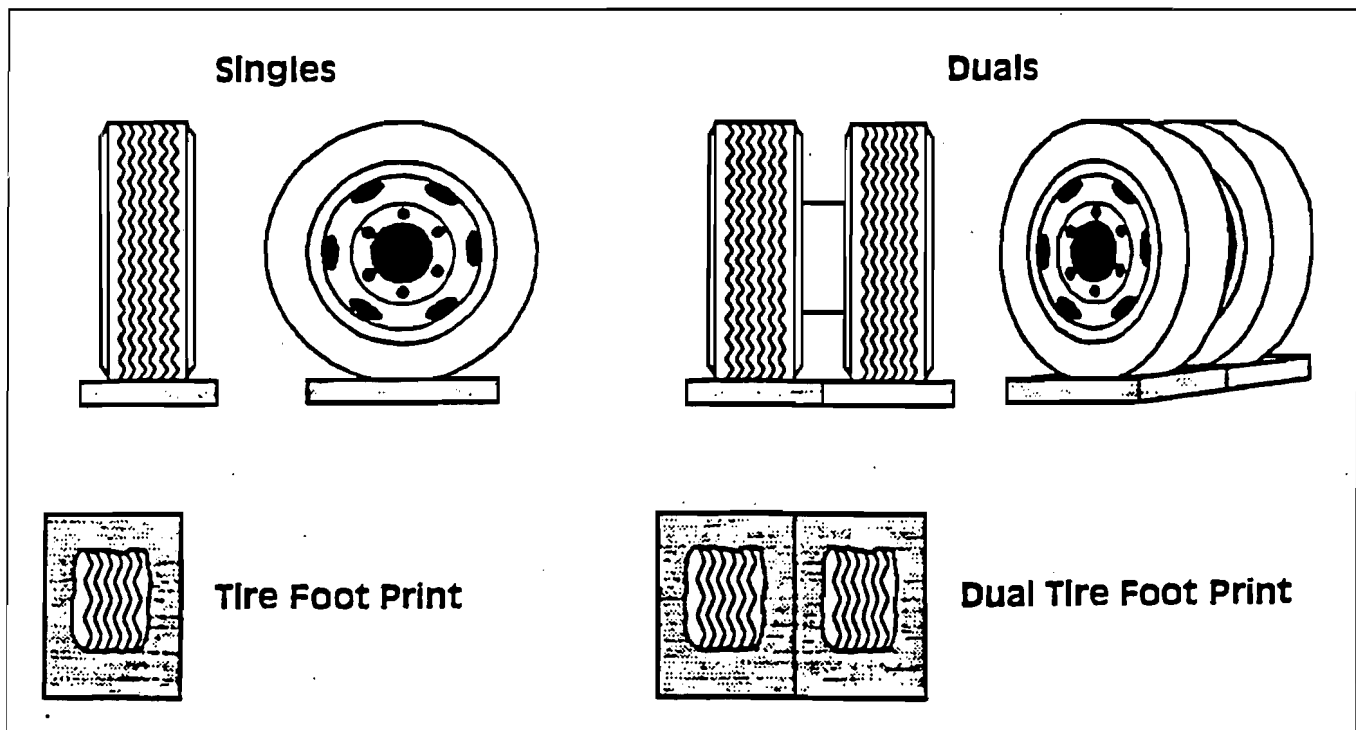

INCORRECT

One tire or a portion of one tire is supporting the full load.

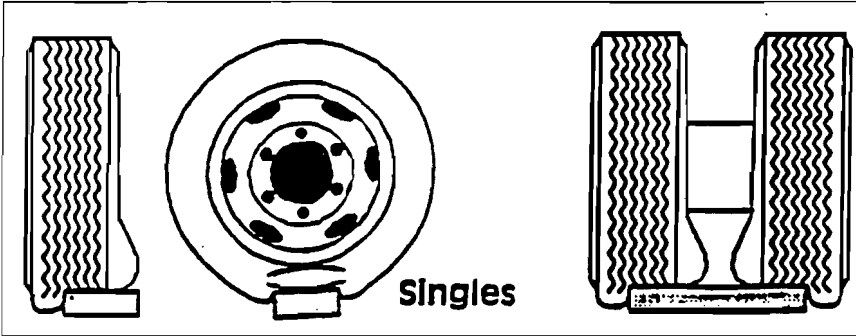
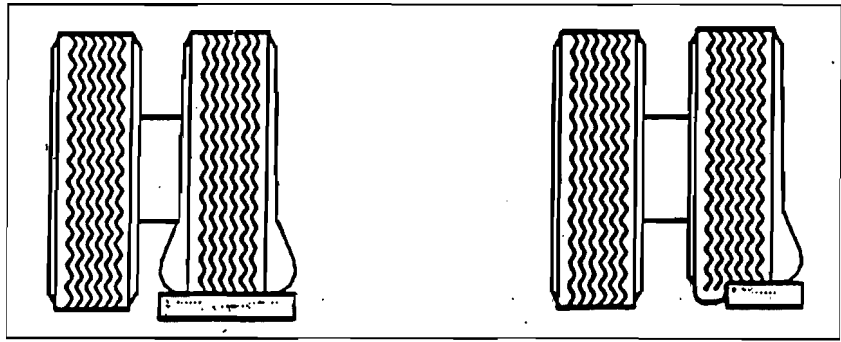

Portion of the two tires supporting the full load.

Tires incorrectly supported, as shown above, may be damaged which could lead to casing failure resulting in serious injury or property damage. If, on previous occasions, the tires have been incorrectly supported, a hidden damage may be present. Please contact your local Michelin dealer and request an inspection and a determination of possible damage.

DASH AIR CONDITIONER/HEATER

Acme Radiator Air Conditioning, Inc.
17103 St. Rd. 4E
Goshen, Indiana 46526
800-552-2263

OPERATION

The dash heater control is very similar to many automobiles.

The center rotary switch marked "cold-hot" controls the amount of hot water flowing through the heater core. When the maximum air conditioner is engaged, inside air is circulated through the evaporator to obtain the utmost in cooling. The two positions marked vent and norm draw outside air through the evaporator.

SERVICE

Acme has requested you to call them on the 800 number listed above should you experience any service problems. They are usually able to help get any repairs needed at an air conditioner repair facility close to your location.

The following pages include wiring diagrams and vacuum line diagrams.

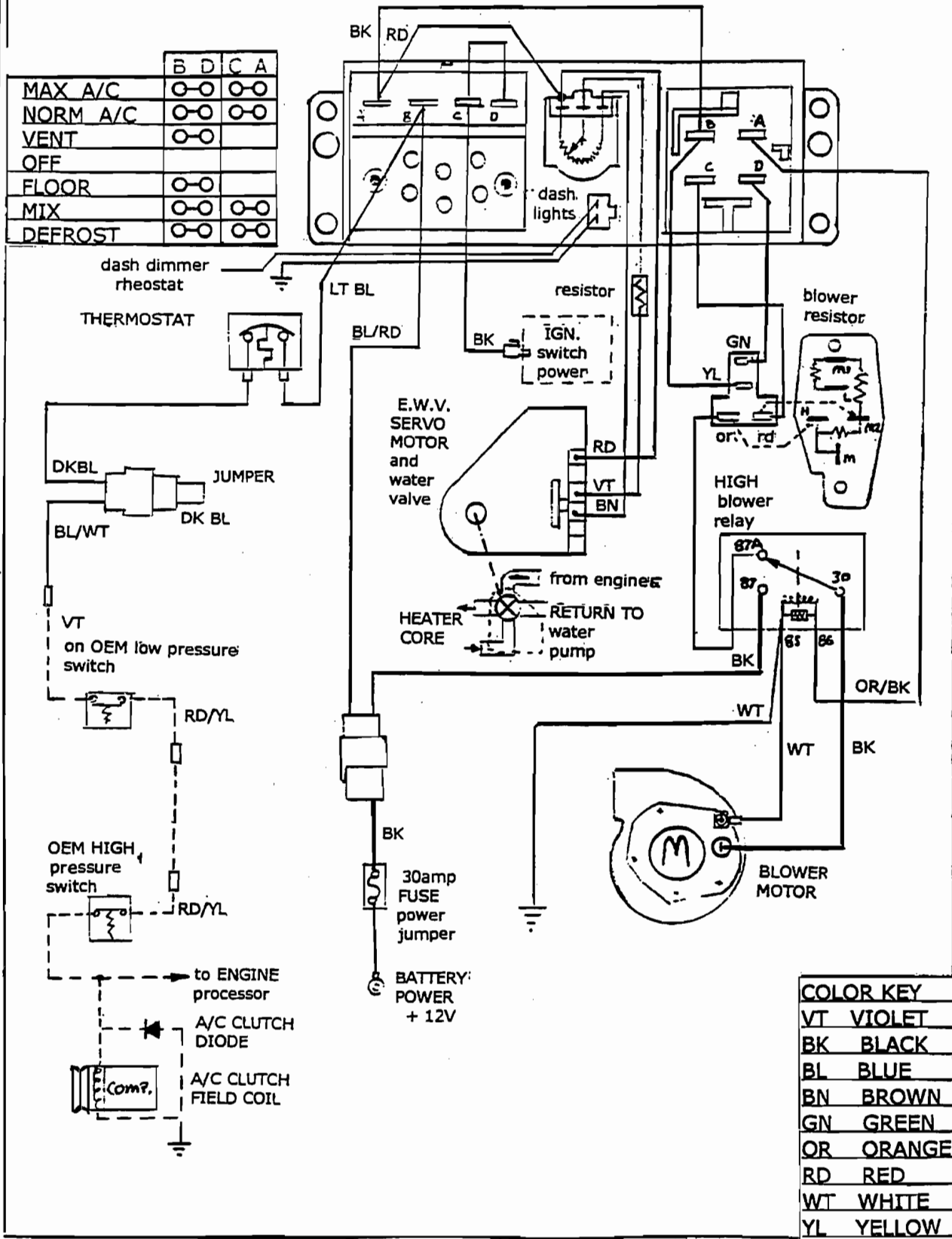

ACME ROTARY CONTROL HEAD W/ELECTRIC WATER VALVE VACUUM DIAGRAM--MODE OPERATING CHART

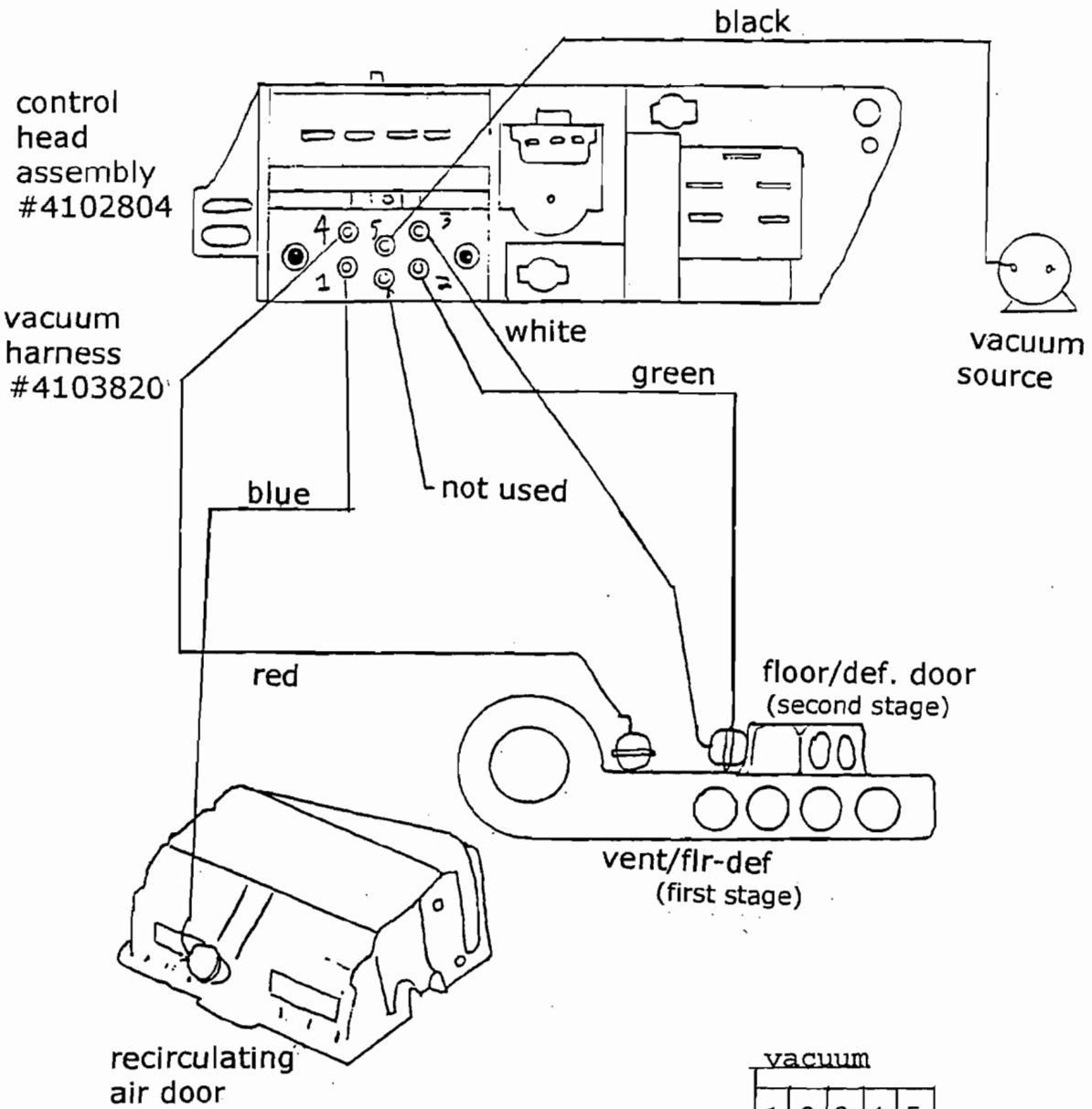

	vacuum				
	1	2	3	4	5
max a/c	x	x	x	x	x
norm a/c		x	x	x	x
vent			x	x	x
off	x	x	x		x
floor			x	x	x
mix				x	x
def					x

5/5/98 SAM

ELECTRIC STEP

Manufacturer: Kwikkee Products Company
Division of Ashton Corporation
P.O. Box 638
Drain, Oregon 97435
Phone: 503-836-2126

The step is easy and convenient to operate. Just inside the main door is a wall switch for the step. When traveling leave the switch in the "ON" position - the step will lower when the door is opened and retract when the door is closed.

When parked, open the door so the step is lowered, Then shut the switch off. The step will remain in the lowered position and the "step" light on the dash will be extinguished. If left on it will run your engine battery down in about a week.

If you forget and leave the switch off as you leave - No Problem! When the ignition is "ON" the wall switch is by-passed and the step will retract when the door is closed.

WARNING: If the wall switch is turned off, and the step is in the retracted position when the ignition is turned off, the step will not lower when the door is opened. Keep your passengers informed.

ELECTRICAL SCHEMATIC

Wiring Diagram for Steps Equipped with the 909506, 909507, or 909508 Control Unit.

Step wiring

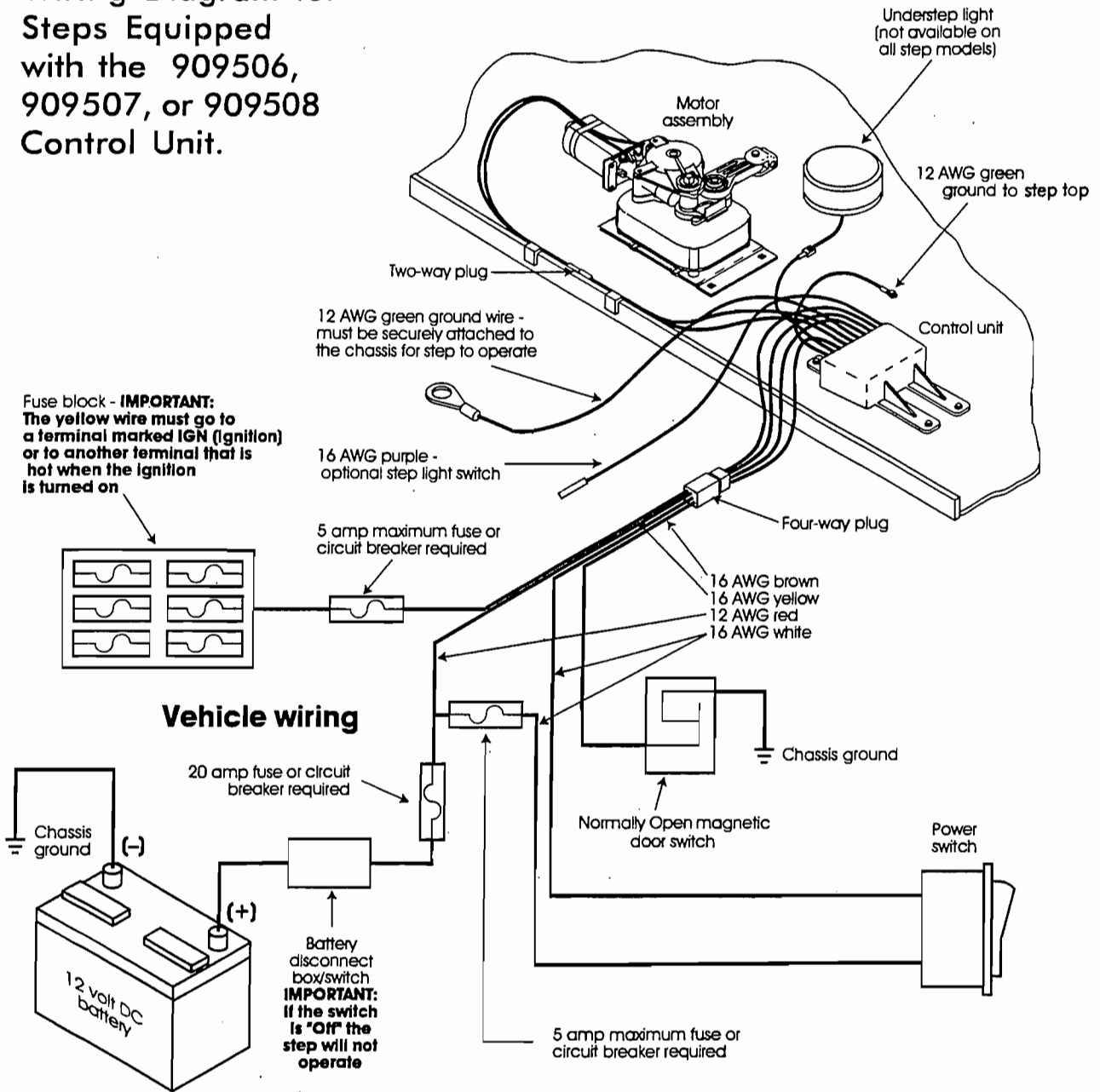

OPERATING THE STEP

1. After the installation is complete and with the entrance door open, turn the power switch on.
2. Close the door. The step should retract and lock in the "up" position.
3. Open the door. The step should extend and lock in the "down" position with the understep light on. **NOTE:** *The under step light is not available on all step models.*
4. Turn the power switch off. The step should remain in the extended position with the understep light off when the door is closed. Turning off the power with the step retracted will hold the step in a retracted position as well.
5. With the power switch off., the step extended, and the entrance door closed, turn on the vehicle ignition. The ignition override system will go into effect and the step will automatically retract. **NOTE -** *If the yellow wire from the four-way connector was not connected to an ignition power source during the installation procedure, the ignition safety system will be inoperative and the step will remain in the extended position. In this case, the power switch must be turned on for the step to retract.*

WARNING: *If the vehicle is driven with the step in the extended position, there is the possibility of causing major damage to both the step and the vehicle.*

6. Turn the vehicle ignition off and open the door. The step will extend and lock in the "down" position. This is the "Last Out" feature.

WARNING: *If the door is opened and closed without allowing the step to fully extend and lock in the "down" position, the step will retract and lock in the "up" position. When the door is reopened, the step will not extend. The power switch must be turned on for the step to extend.*

7. The "Last Out" feature is only operative the first time the door is opened after the vehicle ignition is turned off. **NOTE:** *If the yellow wire from the four-way connector was not connected to the vehicle fuse block during installation, the "Last Out" feature will not operate.*

When the vehicle ignition is on, the step will always activate with the door movement, regardless of power switch position. **NOTE:** *This is not valid if the aforementioned yellow wire has not been connected.*

Be Safe - Look Before You Leap!

General Service Notes

If the power wire to the step is disconnected from its source and reconnected, a spark is common. This is caused by the momentary charging of the control unit and does not necessarily indicate the system is staying on, which would cause a drain on the battery. If battery drain is suspected, observe the understep light (if so equipped) while the step is extending. The power switch must be on for the understep light to operate. When the step locks into the down position, the understep light should become noticeably brighter. If it does not, the control may not be shutting off. Turn the power switch off and unplug the four way plug between the control unit and the vehicle to prevent overheating the step motor.

To further determine that the control is not shutting off, remove the 2 screws from the connector on the step motor leads between the step motor and the control unit. Remove the seal assembly. (See Figure 6 in the Step Test Procedure). Place a voltmeter between the red and yellow motor leads than reconnect the four-way plug. Turn the power switch on. If any voltage registers on the meter, the control is not shutting off and may be defective. When doing this test, switch the voltmeter leads back and forth between the red and yellow motor leads to be sure no voltage registers. If any voltage does register, disconnect the four-way plug to keep the motor from overheating. If zero voltage is present, the control has shut off and is normal.

If the step does not work or operates erratically, such as extending part way and shutting off, the first item that should be checked is the vehicle's battery. The voltage supplied to the step should be at least 12.7 volts DC for well-charged batteries. A battery that registers below 12.7 volts DC may drop as low as 8 volts DC when a load is drawn, such as engaging the step motor. The control unit will shut off if the loaded voltage falls below 9.5 volts DC. The control unit will remember which function it was performing. It will wait between two and five seconds (time depends upon temperature) and will try again to complete the original function. If the supply voltage is still below 9.5 volts DC, the control will go into another delay state. If the supply voltage remains above 9.5 volts DC, the original function will be completed. Should the supply voltage again fall below 9.5 volts DC the system will go into another delay state. It could take a couple of minutes to complete the original function. Low supply voltage may cause erratic operation of the step. Poor ground connections may also cause erratic operation of the step.

The step may also operate erratically if the step is being operated directly from a converter, and the output from the converter is not adequate or properly filtered for clean DC voltage. The converter must be capable of producing a minimum of 30 amps for proper step operation.

If the control unit is hooked up reverse polarity, the step will not operate. If the ground to the control unit is lost, either between the step control unit and the vehicle chassis (the long 10 ga. green ground wire) or between the vehicle battery and the ground (negative battery cable) the step will not function. Make sure the battery terminals and all wire connections are clean and tight. Be sure all wires are of proper gauges or heavier as specified in the wiring diagram.

These general service notes and the Step Test Procedure cover the most common problems associated with Kwikie electric steps. Due to the number of variable conditions available, you may experience symptoms other than those covered. Please feel free to contact the Customer Service Department at 1 (800) 736-9961 for further information or assistance.

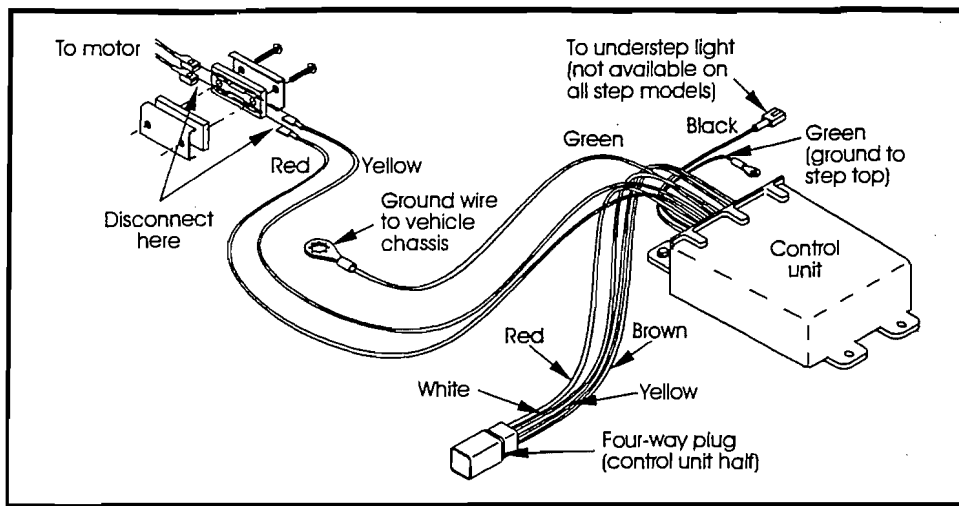

Figure 6

STEP TEST PROCEDURE

This Step Test Procedure has been provided as the easiest and quickest way to troubleshoot and test all of the Kwikkee automatic electric step functions. It is designed to initially check the step basic functions separately from the RV wiring, there by determining whether or not the step is malfunctioning. From that initial determination, the procedure goes on to test the various components of the step until the source of the malfunction is located. Using this procedure will shorten and reduce the time spent troubleshooting.

Some portions of this test require additional equipment. This equipment includes: a voltmeter, a well charged 12 volt DC automotive battery, and a 4-way extended-wire pigtail (Part #909336, available from Kwikkee Products Company).

WARNING: 12 volt automotive batteries contain sulfuric acid which can cause severe burns. Avoid contact with the skin, eyes and clothing. 12 volt automotive batteries produce hydrogen gas which is explosive; keep cigarettes, open flames and sparks away from the battery at all times.

Reading this entire procedure prior to beginning the tests is recommended. Should you need assistance in the course of performing this test procedure, feel free to contact Kwikkee's toll free Service Line at 1 (800) 736-9961.

Testing the Step

NOTE: Prior to beginning the test procedure, check to be sure that all ground connections are securely fastened with good metal-to-metal contact. A good ground is required for proper step operation.

1. Inspect the step for visible damage that might restrict the step's extension.
2. Obtain a 4-way pigtail connector (part #909336) from Kwikkee.
3. Disconnect the 4-way plug on the underside of the step and connect the step-half of the plug with the extended-wire pigtail connector (see Wiring Schematic).
4. Set a fully charged 12 volt DC automotive battery beside the step. **ATTENTION: Do not allow battery terminals to come in contact with the step.** Complete a ground for the step tests by connection a 10 gauge wire from the negative (-) post of the battery to the 10 gauge green ground wire from the control unit.
5. For the power supply, attach the red wire from the extended-wire pigtail to the battery's positive (+) post.

6. With the power and ground connections complete, all functions of the control unit can be checked at the leads to the 4-way extended-wire pigtail. The brown wire is the door switch, the white wire is the power switch, and the yellow wire is the ignition override.
- WARNING: Keep all fingers, arms and legs clear of the step mechanism while performing these tests.**
7. While holding the white wire to the battery's positive (+) post, touch the brown wire to the battery's negative (-) post. The step should extend. Remove the brown wire and the step should retract.
 8. As in Step 7, extend the step again. With the step extended, disconnect the white wire first and then disconnect the brown wire. The step should remain extended.
 9. With the step still extended, touch the yellow wire to the battery's positive (+) post. The step should retract.
 10. At this point, refer to the control unit. On step models with the numbers #909514, #909515 or #909591, all step functions have been tested. Proceed to step 11. On step models with the numbers #909513, #909516, #909590 or #909592, test the "Last Out" feature by disconnecting the yellow wire and then touching the brown wire to the battery's negative (-) post. The step should extend and remain extended.
 11. If any of the step functions do not work, the source of the malfunction is either in the control unit and/or the motor. Proceed to testing the motor section. If all of the step functions do work, the malfunction is either in the door switch, the power switch or the vehicle wiring. Proceed to testing the 4-way plug - vehicle half section.

Testing the Motor

12. Steps equipped with the permanent magnet motor require disconnecting the motor leads from the control unit before applying power to the motor leads (see Figure 6). To disconnect the motor leads, disassemble the motor lead wire connector seal.

NOTE: Failure to disconnect the motor wire leads from the control unit prior to applying power to the motor leads will damage the control unit and void warranty.

NOTE: Do not cut any motor or control unit wire leads. Any leads that have been cut will void the warranty.

After the motor leads have been disconnected, connecting the motor's red wire lead to the positive (+) post of the battery and the motor's yellow wire lead to the negative (-) post of the battery will extend the step. Reversing the lead connections will retract the step. If the step extends and retracts during this test, the condition of the step motor is good.

Testing the 4-way Plug - Vehicle Half

13. To check the main power source, connect the voltmeter between the red wire from the four-way plug (vehicle half) and the ground terminal at the end of the control unit's 10 gauge green ground wire (See Figure 7). The reading should be a minimum of 12 volts DC.

If the voltage reading is low, there may be a loose or corroded connection at the battery, or a low level on the battery itself. If the voltage reading is zero (0) volts, check the 25 amp fuse/circuit breaker, all connections, and the condition of the wiring between the battery and the plug.

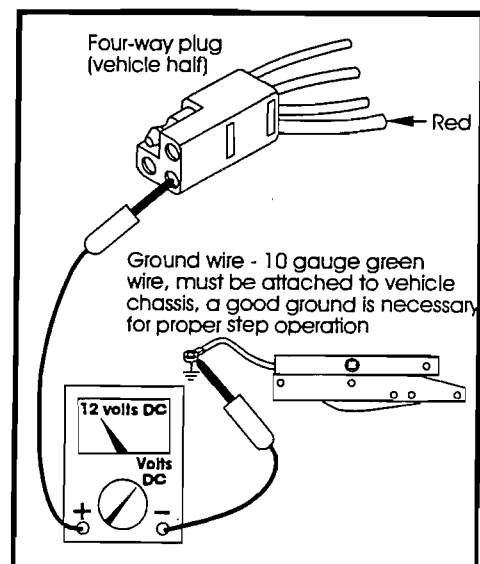

Figure 7

14. To check the power switch, connect the voltmeter between the white wire from the the four-way plug (vehicle half) and the terminal at the end of the control unit's 10 gauge green ground wire (see Figure 8). The reading should be a minimum of 12 volts DC (the same as in Step 13) when the switch is on, and zero (0) volts when the switch is off.

If the voltmeter reads zero (0) volts when the power switch is on, there is a problem in the power switch circuit.

Check the 5 amp in-line fuse, the Power Switch itself and the condition of the circuit's wiring and terminal connections.

15. To check the door switch, connect the voltmeter between the red wire from the four-way plug (vehicle half) and the brown wire in the same plug (see Figure 9). The voltage should be about 12 volts DC (the same as in step 13) when the door is open and zero (0) when the door is closed.

If the readings vary (either zero (0) volts when the door is opened or 12 volts continuously) there is a problem in the door switch. Check the door switch itself and the condition of the circuit's wiring and terminal connections.

16. To check the ignition override system, connect the voltmeter between the yellow wire from the four-way plug (vehicle half) and the ground terminal on the end of the control unit's 10 gauge green ground wire (see Figure 10). The voltage reading should be approximately 12 volts DC when the ignition is on and zero (0) volts when the ignition is off.

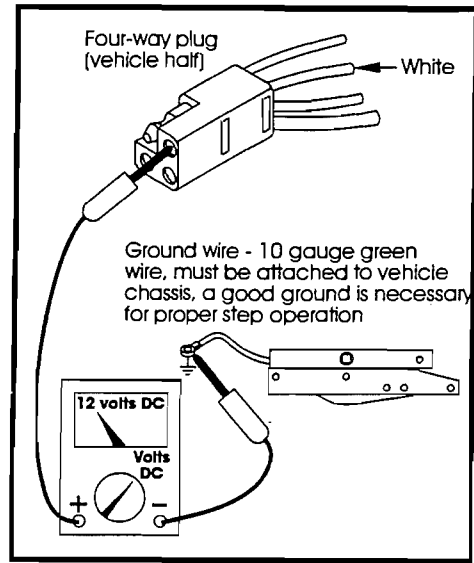

Figure 8

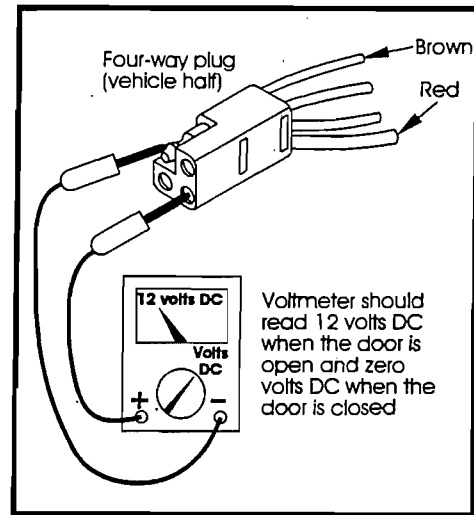

Figure 9

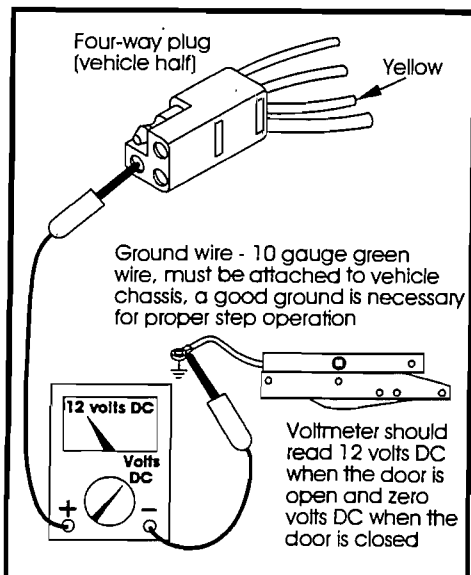

Figure 10

If the reading is zero when the ignition is on, check the terminal connections in the vehicle's fuse/circuit breaker and the condition of the circuit's wiring and terminal connections. **NOTE - The step wiring circuit must be independent. No other device (i.e. alarm systems, step well lights, etc.) can be connected to the step wiring circuit. Any device connected to the steps wiring can cause the step to malfunction and will void the warranty.**

This concludes the Step Test Procedure. At this point, the source of a step's malfunction should be known. If you have additional questions or need more assistance, contact Kwikiee's Service Representative at 1 (800) 736-9961.

STEP MOTOR ASSEMBLY DIAGRAM

Parts shown in this illustration are only available in kit form and cannot be obtained individually; refer to the illustration below and use the Step Motor Parts Key on the preceding page to select the kit that contains the necessary part.

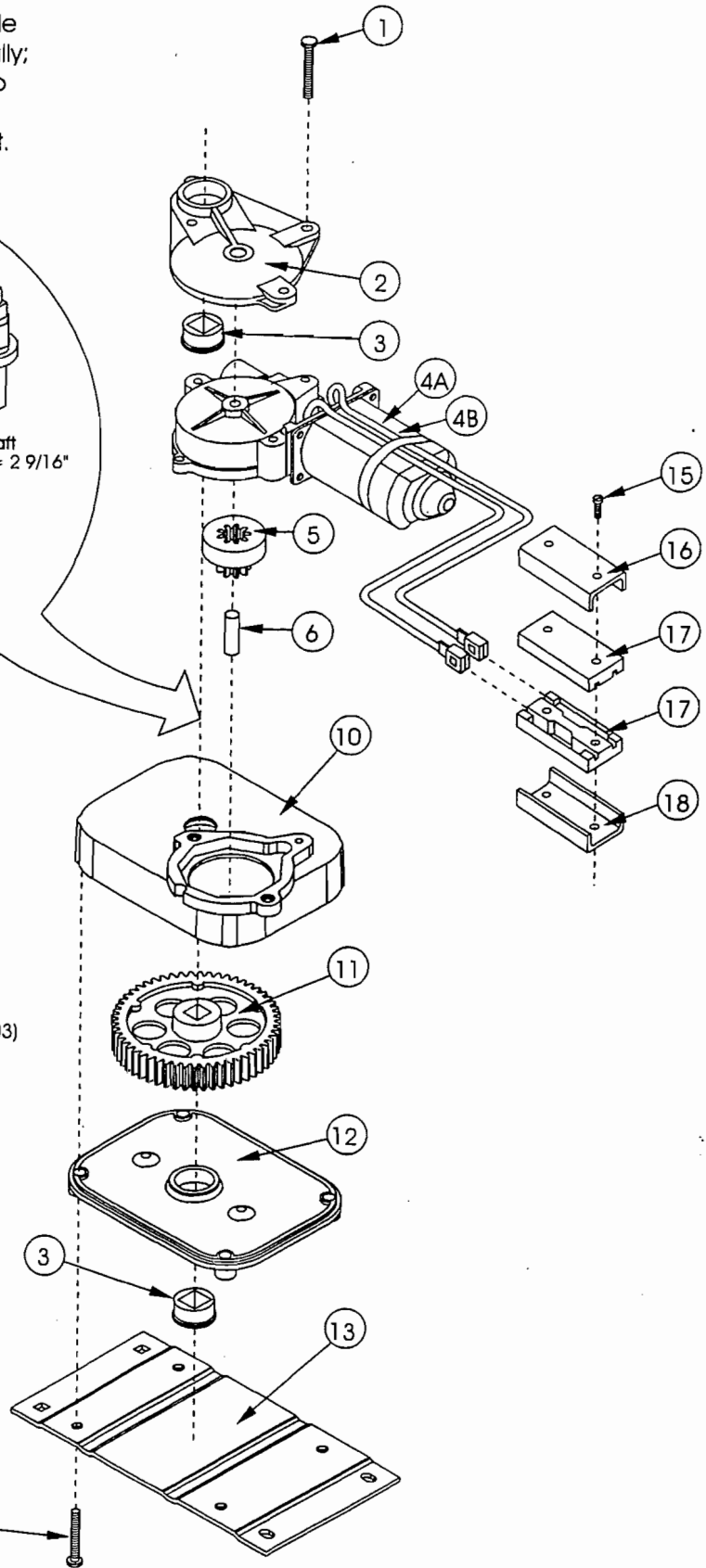
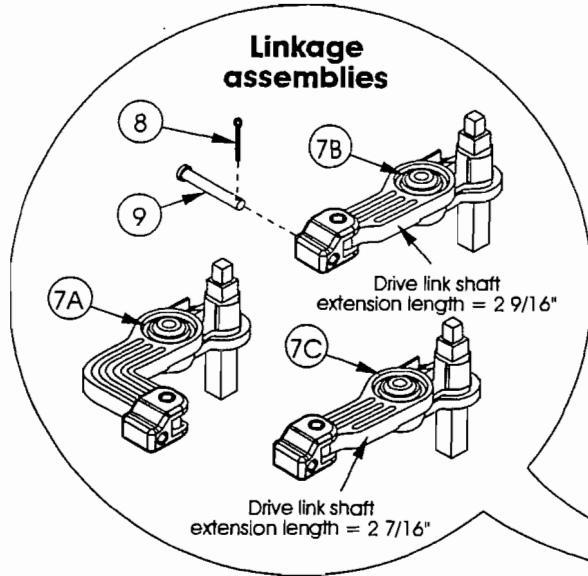

Part# Description

- 1 #10 x 1 3/4" self-tapping hex washer-head screw
- 2 Motor bearing bracket
- 3 Bearing
- 4A Motor
- 4B Motor (high torque - for use with 23 Series steps)
- 5 Adaptor gear
- 6 Adaptor gear shaft
- 7A Linkage assy. (for motor assys. #909502 & #909503)
- 7B Linkage assembly (for motor assembly #909501)
- 7C Linkage assembly (for motor assembly #909504)
- 8 Cotter pin
- 9 Clevis pin
- 10 Gear case
- 11 Gear
- 12 Gear case cover
- 13 Motor mounting plate
- 14 1/4-20 x 1 1/4" tri-lobal thread forming screw
- 15 #6 x 3/4" self-tapping washer-head screw
- 16 Motor lead weather seal - upper plate
- 17 Motor lead connector rubber seal
- 18 Motor lead weather seal - lower plate

Figure 11

LUBRICATION AND MAINTENANCE SCHEDULE

Clean all mud, salt, and road grime from step before lubricating. Lubricate all moving parts (bearings, pivot points, slides, clevis pin, and drive linkage ball) every 30 days with a good quality moisture and heat resistant penetrating grease. Kwik-Lube Spray Grease is specially formulated to lubricate Kwikkee electric steps and is recommended for lubricating all moving parts.

Refer to figures below for lubrication locations:

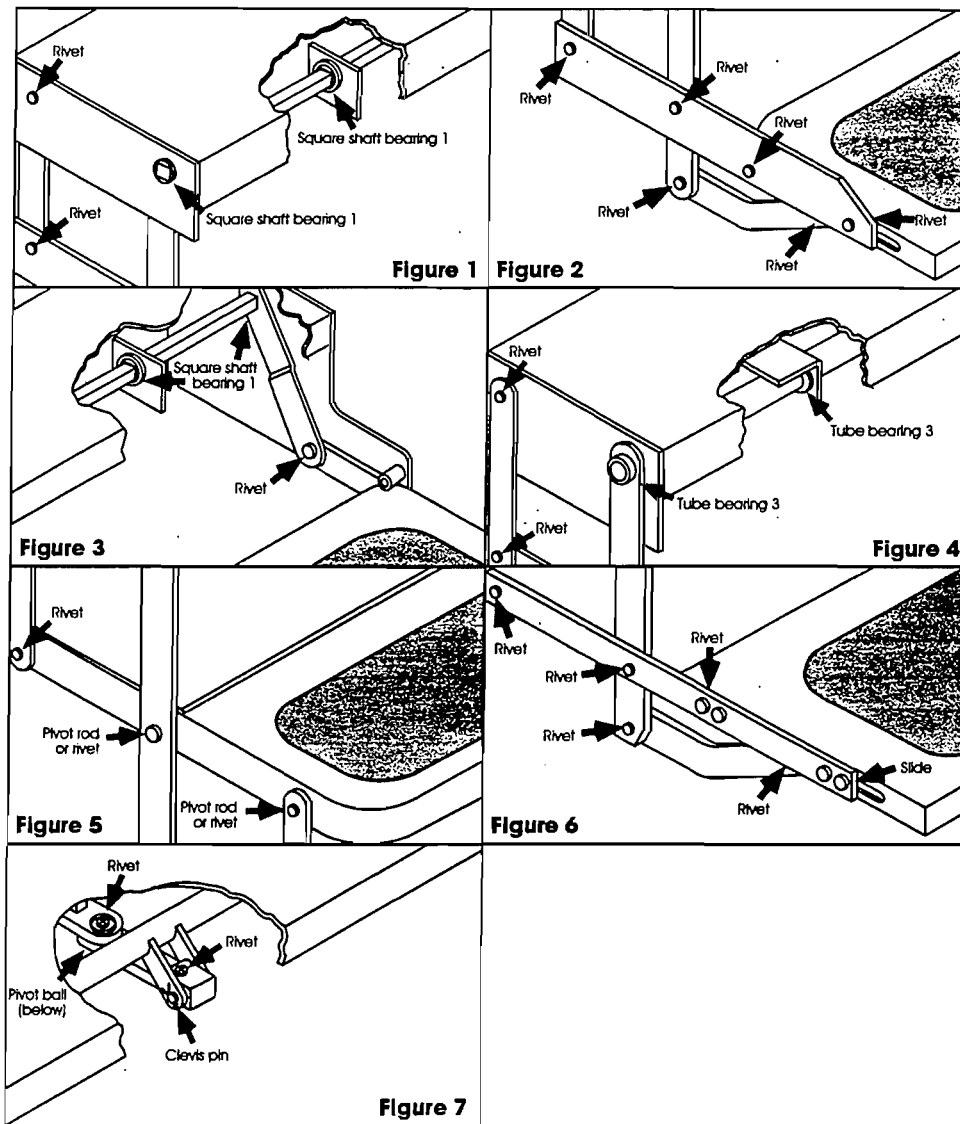

NOTE: Figures are to be used as a general reference only. Some may not pertain to your particular step model. Views are typical to both ends of the steps.

1. Figures 1 & 3 - square shaft bearing - lubricate around outside and under head of bearing.
2. Figure 4 - on step models equipped with plastic cover, this cover will have to be removed to lubricate center bearings. Lubricate bearings under cover every 90 days.
3. Figure 4 - 1" O.D. tube bearing - lubricate around drive tube and between head of bearing and drive leg.

NOTE: We recommend that penetrating oils and silicone lubricants not be used on the step as they do not last.

STEP WELL COVER

Your motorhome is equipped with a pneumatically powered step well cover.

The switch (valve) is a black lever located in the front of the passenger right hand arm rest. The air pressure is supplied by the chassis air ride system. It is normal for the air system to leak down so you may find the cover to be inoperable if the engine has been shut off for a period of time.

The intent of the step cover is to provide the passenger with a "floor" while traveling and then be retracted so the steps can be used when stopped. With this in mind you can see where the loss of air after the motorhome has been shut off for a time is not a problem. When you park the motorhome you'll normally retract the step cover so you can at least get out and stretch your legs.

If you happen to lose air pressure before retracting the step cover just starting the engine for a few minutes will replenish the air supply.

CAMPING

SAFETY

As always, safety should be one of your top priorities. Make sure you, and everyone traveling with you, can operate the main door and exit window rapidly without light.

WARNING: *The escape window (which is the rear, roadside windows) is opened by rotating the red latch handle down then pushing the sash out. The pleated shade is opened by sliding it straight up. The window operation should be checked each trip.*

WARNING: *At each campsite make sure you have not parked in such a manner as to block the operation of the escape window by being too close to trees, fences or other impediments. Scenic views are one reason for traveling, but don't park so the beautiful lake or steep cliff is just outside your escape window.*

WARNING: *Read the directions carefully on the fire extinguisher. If there is any doubt on the operation, you and your family should practice, then replace or recharge the extinguisher. You will find your local fire department will be happy to assist you and answer any questions.*

WARNING: ***DON'T SMOKE IN BED!**
KEEP MATCHES OUT OF REACH OF SMALL CHILDREN!
DON'T CLEAN WITH FLAMMABLE MATERIAL!
KEEP FLAMMABLE MATERIAL AWAY FROM OPEN FLAME!*

We have all heard these warnings many times, but they are still among the leading causes of fires.

Other safety information on the LPG system of your motorhome is located in the Plumbing Section of this manual.

SMOKE ALARM

OPERATION, TESTING

OPERATION: The smoke detector is operating once a fresh battery is installed and testing is complete. When products of combustion are sensed, the unit sounds a loud 85 db pulsating alarm until the air is cleared.

HUSH CONTROL: The "HUSH" feature has the capability of temporarily desensitizing the alarm circuit for approximately 7 minutes. This feature is to be used only when a known alarm condition, such as smoke from cooking, activates the alarm. The smoke detector is desensitized by pushing the "HUSH" button on the smoke detector cover. If the smoke is not too dense, the alarm will silence immediately and "Chirp" every 30-40 seconds for approximately 7 minutes. This indicates that the alarm is in a temporarily desensitized condition. The smoke alarm will automatically reset after approximately 7 minutes and sound the alarm if particles of combustion are still present. The "HUSH" feature can be used repeatedly until the air has been cleared of the condition causing the alarm.

NOTE: DENSE SMOKE WILL OVERRIDE THE HUSH CONTROL FEATURE AND SOUND A CONTINUOUS ALARM.

CAUTION: BEFORE USING THE ALARM HUSH FEATURE, IDENTIFY THE SOURCE OF THE SMOKE AND BE CERTAIN A SAFE CONDITION EXISTS.

FLASHING L.E.D. LIGHT: This smoke detector is equipped with a flashing red indicator light. The light is located under the test button and will flash every 30-40 seconds to indicate that the smoke detector is receiving power.

TESTING: Test by pushing the test button on the cover and holding it down for a minimum of 2 seconds. This will sound the alarm if all the electronic circuitry, horn and battery are working. If no alarm sounds the unit has defective batteries or other failure. You can also test the alarm by blowing smoke into it.

TEST THE ALARM WEEKLY TO ENSURE PROPER OPERATION. Erratic or low sound coming from your alarm may indicate a defective detector, and it should be returned for service.

FALSE ALARMS

Smoke detectors are designed to minimize false alarms. Cigarette smoke will not normally set off the alarm, unless the smoke is blown directly into the detector. Combustion particles from cooking may set off the alarm if the detector is located close to the cooking area. Large quantities of combustible particles are generated from spills or when broiling. Using the fan on a range hood which vents to the outside (non recirculating type) will also help remove these combustible products from the kitchen.

MODEL 0916 HAS A "HUSH" CONTROL that is extremely useful in a kitchen area or other areas prone to nuisance alarms. For more information refer to **OPERATION AND TESTING**.

If the detector does alarm, check for fires first. If a fire is discovered, get out and call the fire department. If no fire is present check to see if other reasons may have caused the alarm.

MAINTENANCE

BATTERY REPLACEMENT

To replace the battery remove the detector from the mounting plate by rotating the detector in the direction of the "OFF" arrow on the cover.

The Model 0916 Smoke Detector uses one (1) 9 volt battery. The **SMOKE DETECTOR** is powered by a 9V carbon zinc battery (**alkaline** battery may also be used). A fresh battery should last for one year under normal operating condition. This detector has a low battery monitor circuit which will cause the detector to "chirp" approximately every 30-40 seconds for a minimum of seven (7) days when the battery gets low. Replace the battery when this condition occurs. **USE ONLY THE FOLLOWING 9 VOLT BATTERIES FOR SMOKE DETECTOR REPLACEMENT.**

Carbon-zinc type: EVEREADY 216 OR 1222
GOLD PEAK 1604P OR 1604S

Alkaline type: EVEREADY 522; DURACELL MN1604;
Gold Peak 1604A

Lithium type: ULTRALIFE U9VL.

NOTE: REGULAR TESTING IS RECOMMENDED.

WARNING!! USE ONLY THE BATTERIES SPECIFIED. USE OF DIFFERENT BATTERIES MAY HAVE A DETRIMENTAL EFFECT ON THE SMOKE DETECTOR.

NOTE: IF AFTER BATTERY REPLACEMENT, THE UNIT CONTINUES TO CHIRP, WAIT FOR APPROXIMATELY 7 MINUTES. THE "HUSH" FEATURE MAY HAVE BEEN ACTIVATED ACCIDENTALLY WHILE CHANGING THE BATTERIES AND WILL RESET AUTOMATICALLY.

CLEANING YOUR DETECTOR:

To clean your detector remove it from the mounting bracket as outlined in the beginning of this section.

You can clean the interior of your detector (sensing chamber) by using your vacuum cleaner hose and vacuuming through the openings around the perimeter of the detector.

The outside of the detector can be wiped with a damp cloth.

AFTER CLEANING, REINSTALL YOUR DETECTOR. TEST YOUR DETECTOR BY USING THE TEST BUTTON.

LIMITATIONS OF SMOKE ALARMS:

WARNING!! Smoke detectors are devices that can provide early warning of possible fires at a reasonable cost; however, detectors have sensing limitations. Ionization type detectors offer a broad range of fire sensing capability but are better at detecting fast flaming fires than slow smoldering fires. Photoelectric detectors sense smoldering fires better than flaming fires. Home fires develop in different ways and are often unpredictable. Neither type of detector (photoelectric or ionization) is always best, and a given detector may not always provide warning of a fire. Also, smoke detectors do have limitations. For a battery powered detector the battery must be of the specified type, in good condition, and installed properly. AC powered detectors will not operate if AC power has been cut off such as by an electrical fire or an open fuse. Smoke detectors must be tested regularly to make sure the batteries and the detector circuits are in good operating condition.

Smoke detectors cannot provide an alarm if smoke does not reach the detector. Therefore, smoke detectors may not sense fires starting in chimneys, walls, on roofs, on the other side of a closed door or on a different floor. If the detector is located outside the bedroom or on a different floor, it may not wake up a sound sleeper. The use of alcohol or drugs may also impair ones ability to hear the smoke alarm. For maximum protection a smoke detector should be installed in each sleeping area on every level of a home.

Although smoke detectors can help save lives by providing an early warning of a fire, they are not a substitute for an insurance policy. Home owners and renters should have adequate insurance to protect their lives and property.

GOOD SAFETY HABITS

DEVELOP AND PRACTICE A PLAN OF ESCAPE:

- Make a floor plan indicating all doors and windows and at least two (2) escape routes from each room. Second story windows may need a rope or chain ladder.
- Have a family meeting and discuss your escape plan, showing everyone what to do in case of fire.
- Determine a place outside your home where you all can meet if a fire occurs.
- Familiarize everyone with the sound of the Smoke Alarm and train them to leave your home when they hear it.
- Practice a fire drill at least every six months. Practice allows you to test your plan before an emergency, you may not be able to reach your children. *It is important they know what to do.*

WHAT TO DO WHEN THE ALARM SOUNDS:

- Leave immediately by your escape plan. Every second counts, so don't waste time getting dressed or picking up valuables.
- In leaving, don't open any inside door without first feeling its surface. If hot, or if you see smoke seeping through cracks, *don't open that door!* Instead use your alternate exit. If the inside of the door is cool, place your shoulder against it, open it slightly and be ready to slam it shut if heat and smoke rush in.
- Stay close to the floor if the air is smokey. Breathe shallowly through a cloth, wet if possible.
- Once outside go to your selected meeting place and make sure everyone is there.
- Call the fire department from your neighbors home — *not from yours!*
- Don't return to your home until the fire officials say that it is all right to do so.

There are situations where a smoke detector may not be effective to protect against fire as stated in the NFPA standards 72.

For instance:

- a) smoking in bed;
- b) leaving children home alone;
- c) cleaning with flammable liquids, such as gasoline.

Further information on fire safety can be obtained in a pamphlet titled "IN A FIRE SECONDS COUNT" published by the NFPA, Batterymarch Park, Quincy, Mass. 02269.

SERVICE AND WARRANTY

If after reviewing this manual you feel that your smoke alarm is defective in any way, do not tamper with the unit. Return it for servicing to: FYRNETICS, INC., 1055 STEVENSON CT./STE 102W, ROSELLE, IL 60172. (See Warranty for in-warranty returns).

CARBON MONOXIDE ALARM

The following information is highlights from the folder provided by the alarm manufacturer. The folder, with more detailed information, is contained in your Owners' Packet.

Test detector immediately following installation and weekly for proper operation by pushing the test button until the YELLOW L.E.D. lights and a short beep is heard (approximately three seconds). Release the button. The detector will then test itself for proper operation. At completion of the self test, the alarm will sound and both L.E.D.s will light for 3/4 of a second. The detector then resumes normal operation.

NORMAL OPERATION

In normal operation the detector will flash the RED L.E.D. once every 30 seconds.

WARNING CONDITION

If the COSTAR senses a low level of CO The YELLOW L.E.D. will light and the detector will beep every three seconds warning that CO is present. The area should immediately be ventilated. A concentration of 60 PPM within 67 minutes will cause the warning condition. Pushing the test button will silence the warning signal but the YELLOW L.E.D. will stay on. After two hours the warning signal will sound again if the CO source has not been eliminated. If the condition persists there is a possibility that it may cause the unit to enter alarm condition (below). If this occurs pushing the reset button will silence the alarm for 30 minutes.

ALARM CONDITION

If the COSTAR senses unsafe levels of CO, the RED L.E.D. will light up and the alarm will sound. The alarm condition will be signified by a repetitive alarm sounding pattern of approximately 4.5 seconds on 1.5 second off. Immediate evacuation is required. Pushing the test button will silence the alarm once for approximately 4 minutes.

After approximately 4 minutes the alarm will once again sound until the unsafe CO concentration is removed.

FAULT CONDITION

Periodically the detector's measurement circuit is tested. If an error is detected, the detector will sound twice and the YELLOW L.E.D. will flash twice every 30 seconds. This is an indication of circuit malfunction and that the detector requires immediate servicing.

MAINTENANCE

Battery Replacement:

If tamper resistant pin has been used, refer to "tamper resistant locking pin" for removal instructions.

To replace the battery remove the detector from the mounting plate by rotating the detector in the direction of the "OFF" arrow on the cover.

The **Model 9L-i CO Detector** uses on (1) 9 volt battery. The **CO DETECTOR** is powered by a 9V alkaline battery. A fresh battery should last for one year under normal operating conditions. This detector has a low battery monitor circuit which will cause the detector to "chirp" and the red LED to flash approximately every 30-40 seconds for a minimum of seven (7) days when the battery gets low. Replace the battery when this condition occurs. **USE ONLY THE FOLLOWING 9 VOLT BATTERIES FOR CO DETECTOR REPLACEMENT.**

Alkaline type: EVEREADY 522; DURACELL MN1604

GOLD PEAK 1604A

Lithium type: ULTRALIFE U9VL

NOTE: REGULAR TESTING IS RECOMMENDED.

WARNING!! USE ONLY THE BATTERIES SPECIFIED. USE OF DIFFERENT BATTERIES MAY HAVE A DETRIMENTAL EFFECT ON THE CO DETECTOR.

CLEANING YOUR DETECTOR:

To clean your detector remove it from the mounting bracket as outlined in the beginning of this section.

You can clean the interior of your detector by using your vacuum cleaner hose and vacuuming through the openings around the perimeter of the detector.

The outside can be wiped with a damp cloth.

AFTER CLEANING, REINSTALL YOUR DETECTOR. TEST YOUR DETECTOR BY USING THE TEST BUTTON.

Test detector weekly for proper operation by pushing the test button until the YELLOW L.E.D. lights and a short beep is heard (approximately three seconds). Release the button. The detector will then test itself for proper operation. At completion of the self test, the alarm will sound and both L.E.D.s will light for 3/4 of a second. The detector then resumes normal operation.

SERVICE AND WARRANTY

If after reviewing this manual you feel that your CO Detector is defective in any way, do not tamper with the unit. Return it for servicing to: **Quantum Group, Inc., 11211 Sorrento Valley Road, Suite V. San Diego, CA 92121.**

Or call us toll free (800) 432-5599

E-mail address: mktsls@qginc.com

LP GAS DETECTOR

In the kitchen area of your unit, approximately six inches above the floor, is the LP gas detector. LP gas is a mixture of gases produced and sold commercially as a fuel for heating and cooking appliances. LP gas is highly flammable and, as a result, can be explosive if ignited under certain circumstances. LP gas is heavier than air and, if confined in a closed space, will accumulate close to the floor. When the LP gas concentration in your unit exceeds 2000 ppm the detector will provide a visual and audible alarm by sounding a buzzer and flashing the red LED two times per second.

WARNING

Activation of this detector indicates the presence of LP gas which can cause an explosion and/or fire. This normally indicates a leak in the LP gas installation or a LP gas appliance. Extinguish all open flames, open your windows and door and evacuate the unit immediately. Do not activate any electrical switch. Turn off the LP at your gas bottle(s). **DO NOT RE-ENTER YOUR UNIT UNTIL THE PROBLEM HAS BEEN CORRECTED BY A QUALIFIED REPAIR TECHNICIAN.**

OPERATION

Your LP gas detector is wired directly to your vehicle battery and incorporates a 1 amp. in-line fuse. When the device is operating normally the green LED will be lit.

WARNING

It is not recommended that the detector be disconnected from the battery during periods of storage. There is a small heater on the sensor of the device which "burns" away impurities in the air during periods of normal use. During periods when power is interrupted, impurities can build up on the sensor. When power is returned to the detector the detector alarm may activate until the impurities are "burned" off. This could take a number of hours, during which time the alarm will be constantly "on".

DETECTOR TEST

Press the test button for 5 to 6 seconds until the alarm sounds then release the test button. The red LED should flash and the alarm sound for approximately 4 minutes. This test should be performed at least once a week during normal vehicle operation, and after periods of storage, and before each trip.

LOW VOLTAGE

Below 10 VDC the detector will continue to operate but will blink alternately green and orange. Below 8 VDC the unit will behave erratically and will eventually shut off. To ensure proper operation, do not operate the unit below 10 VDC.

COMPONENT FAILURE

The failure of any circuit component will cause the detector to display a continuous orange LED fault light and a short beep indicating failure. If this occurs, immediately contact your dealer or Airstream Customer Service for the name of the nearest detector service center.

Please read the operating instructions for your detector which have been supplied with the paper work of your unit.

OVERNIGHT STOP

In time you will develop a knack for spotting wonderful little roadside locations by turning off the main highway and exploring. There are many modern recreational vehicle parks, including State, County and Federal parks with good facilities, where you may obtain hookups of electrical, water and sewer connections. Directories are published which describe in detail these parks and tell what is available in the way of services and hookups.

Overnight or Weekend Trips

On overnight or weekend trips, chances are you will not use up the capacity of the sewage holding tank, deplete the water supply, or run down the batteries which supply the living area 12 volt current.

Longer Trip

On a longer trip, when you have stayed where sewer connections and utility hookups were not available, it will be necessary for you to stop from time to time to dispose of the waste in the holding tank and replenish the water supply. Many gas stations (chain and individually owned) have installed sanitary dumping stations for just this purpose. Booklets are available which list these dumping stations.

When you stop for the night, your Airstream motorhome is built to be safely parked in any spot that is relatively level and where the ground is firm. Your facilities are with you. You are self-contained. Try to pick as level a parking spot as possible.

Hydraulic Leveling Jacks

Some models are equipped with hydraulic leveling jacks that can be deployed. Complete instructions are included with the Owners Packet. Be sure to read the directions completely prior to operating the jacks. The jacks will be able to level your unit in most modern campgrounds. However, their capabilities are limited, and in some situations you will have to use planks to level the coach.

All you need to do to enjoy the self-contained luxury is to:

1. Turn on LP gas supply and light appliance pilots if required.
2. Turn on water pump and open faucets until air is expelled from the system.
3. Deploy slide-out if so equipped and you desire the extra space.

Before moving on, turn off the LP gas and water pump, check your campsite, both for cleanliness and also to be sure you haven't left anything behind. Make sure everything is properly stowed.

WINTER TRAVELING

Traveling in your motorhome during the cold winter months can be a most exhilarating experience.

There are, of course, certain precautions which must be taken as you would in your home in low temperatures.

WARNING: Always shut off the LP gas when refueling your motorhome.

Some states do not allow LPG to be turned on while moving. While traveling in these states you must use your common sense. How cold is it? How long will it be before you can turn the heat back on? Is the temperature dropping or rising? Remember, the wind chill factor when driving 50 MPH will cause the interior of the motorhome to cool much faster than when it is parked.

1. You must have a plentiful supply of propane gas.
2. If your stay is longer than overnight, you should endeavor to have 120-volt electricity available. The batteries, fully charged, will not last more than about 15 hours in freezing weather. Of course, you can run your generator to recharge the batteries, or even use the generator continually.
3. Minimize use of electricity if 120 volt power source is not available.
4. Leave cabinet doors, bed doors and wardrobe doors slightly open at night to allow circulation of air in and around all furniture components.
5. Use propylene glycol type antifreeze in waste and drain water tanks to prevent freezing. Quantity of antifreeze needed will vary with ambient temperature and the amount of liquids in tank.
6. For extended stays in cold weather, insulate the water line outside the motorhome. You should remember that low temperatures in combination with high winds cause an equivalent chill temperature much below what your thermometer is reading. For instance, with an outside temperature of zero degrees, and the wind velocity of 10 miles per hour, the equivalent chill temperature is minus 20° F.

Condensation

It is also important to guard against excessive humidity inside your motorhome during winter campouts. When windows and window frames fog up or "sweat," it means that there is too much moisture in the air. Moisture comes from water vapor and water vapor is the direct result of water evaporating.

Many things such as baths and showers, boiling foods, washing dishes, washing clothes, even breathing, contribute to evaporation. The inside air can only absorb so much of this moisture before it becomes saturated. At this point it can hold no more, and any additional water vapor condenses back to liquid water in the form of droplets on any available cool, solid surface. Temperature has a direct effect on the air's saturation point. Cold air holds less moisture than warm air. For this reason, the air immediately adjacent to cold outside walls and windows cools down and causes water vapor to condense and form moisture droplets, even though warmer inside surfaces are still dry.

The best way to keep condensation under control is to reduce moisture producing activities. It is important to provide adequate ventilation and keep the air circulating as much as possible.

Use your exhaust fans to remove moisture before water vapor mixes with the air. Open windows slightly once in a while, while operating fans, to bring in drier outside air and aid in overall air circulation. In extremely cold weather, when outside ventilation is not practical, it may be necessary to use a small dehumidifier to aid in reducing condensation.

There is no substitute for common sense in cold weather.

Note: The Airstream motorhome is built as a recreational vehicle and is not intended as a permanent dwelling or for more than temporary use in sub-freezing temperatures.

EXTENDED STAY

Making a long trip is not very different from making a weekend excursion. Since everything you need is right at hand, you are at home wherever you go. When packing for an extended trip, take everything you need, but only what you need.

Some models are equipped with Hydraulic Leveling Jacks that can be deployed. Complete instructions are included with the Owners Packet. Be sure to read the directions completely prior to operating the jacks.

When you plan to stay in the same place for several days, weeks or months, you will want your motorhome to be as level as possible. Check the attitude with a small spirit level set on the inside work counter. If a correction is necessary, then you must first level from side to side. This can be done most easily by driving up a small ramp consisting of 2" x 6" boards tapered at both ends. WE DO NOT RECOMMEND PLACING TIRES IN A HOLE FOR LEVELING.

CAUTION: To operate the SLIDE-OUT room you MUST first remove the interior travel locks. These are located on the top of the room on the interior of the coach and are out of your normal sight. There are two and they provide pressure between the exterior wall of the coach and the top facer board on the room. They have caming action and the tension is adjustable. The first time you remove them you'll probably need to stand on a stable step stool to see how the cam is released. After seeing their simple operation you may be able to operate them from the floor according to your height and strength. Also **make sure the drivers seat** is forward enough to clear the room.

NOTE: Before the optional slide-out room can be deployed the ignition switch must be off. We also recommend leveling the coach prior to deploying the slide-out.

To operate the SLIDE-OUT ROOM, push and hold the rocker switch located at the top of the control panel in the hallway. You'll easily be able to tell by the sound of the mechanism when the room is fully extended or retracted.

Hook Up to Water by attaching a 1/2" minimum high pressure water hose to the city water service.

The 110 volt power cord is on an electrically operated cord reel in the first compartment behind the roadside rear wheels. Turning the switch to "out" will extend the power cord so it can be plugged into City Power Service.

WARNING: If adapters are required make sure the polarity is correct and the "ground" function is not lost.

A Cable TV Hookup is located on the roadside rear corner of the motorhome. It is already wired into the existing system, so the exterior connection is all that is required.

To use the Generator you simply start it. All switching is done automatically. The generator can be started either from your interior monitor panel, dash switch or the switch on the generator itself.

It is easier on your generator and appliances if you'll allow the generator to reach its normal operating speed (about a minute) prior to applying heavy current loads.

Hook your Waste Drain Hose into the Sewer Disposal Facility and attach to the drain outlet in your motorhome. For details on this procedure see Drain and Waste System Section.

Turn on the gas supply and lighting a top range burner to bleed any air from the system will make it easier to start other appliances.

When you stay for extended periods where electric or water hookups are not available, you must make regular checks on the condition of your 12 volt battery and the contents of your water tank. Carry drinking water in a clean bucket to refill your tank. When your waste tank nears capacity, move your motorhome to a dumping location.

NOTES

EXTERIOR

The side walls and roof of your motorhome are laminated fiberglass. There is no magic to caring for your motorhome. As a general rule of thumb, we recommend the motorhome be washed about every four weeks and waxed in the spring and fall. To make sure your new unit is always protected, you should wax it immediately or have your dealer wax it just prior to delivery. In industrial areas cleaning and waxing should be done on a more frequent schedule.

ALWAYS CLEAN YOUR MOTORHOME IN THE SHADE OR ON A CLOUDY DAY WHEN THE SKIN IS COOL. Oil, grease, dust and dirt may be removed by washing with any mild non-abrasive soap or detergent. Cleaning should be followed by a thorough clean water rinse. Spots and streaks may be prevented by drying the unit with a chamois or a soft cloth.

After cleaning and drying, a good grade of automotive paste or liquid wax will increase the life of the finish, especially in coastal areas where the finish is exposed to salt air, or in polluted industrial areas. It will also protect the shell from minor scratches and make subsequent cleaning easier.

It is important to remove sap, gum, resin, asphalt, etc., as soon as possible after they appear by washing and rewaxing. Sunlight and time will bake-harden these materials, making them almost impossible to remove without heavy buffing. If asphalt remains on the motorhome after washing, use a small amount of kerosene on a rag and wipe the spots individually, being careful not to scratch the finish.

If your motorhome has become chalked, or has rub marks, the "new" look can usually be restored. This is best left to a professional. We find Marinas, with their many years of experience with fiberglass, to be one of the best sources of expertise, and stock waxes and cleaners designed for fiberglass.

It is recommended that the caulking and sealant used in external seams and joints such as window frames, light bezels, beltline and rub-rail molding, etc., be checked regularly. If this material has dried out and becomes cracked or checked, or if a portion has fallen out, it should be replaced with fresh material to prevent possible rain leaks. Caulking and sealing material is available from your dealer.

Roof Ladder and Storage

For traveling, the lower section of the ladder should be removed and stored in one of your lower compartments.

To remove, pull out the cross pins in the lower sockets then pull the bottom of the ladder out of the sockets. This will allow the top of the ladder to be unhooked freeing it for storage.

CAUTION: Roof storage is limited to 250 pounds evenly distributed.

MAIN DOOR LOCK

LOCK ASSEMBLY, MAIN DOOR

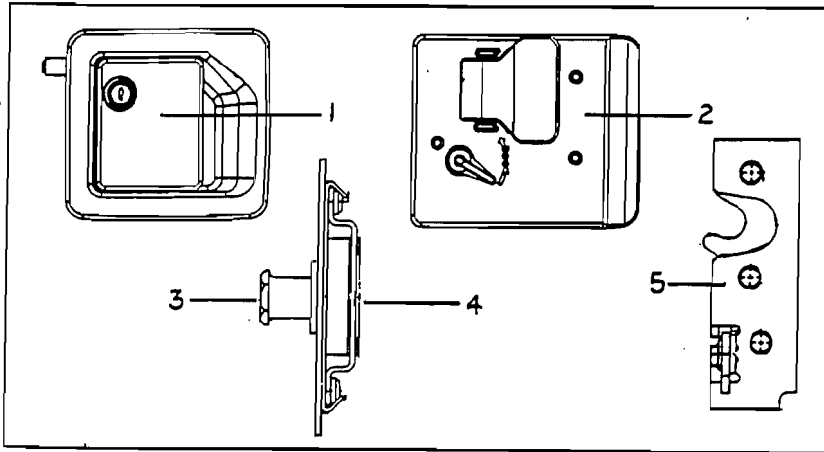

1. Outside housing assembly
2. Inside plate
3. Striker bolt
4. Caged nut
5. Rotary latch

KEYLESS DOOR LOCK (OPTIONAL)

The dead bolt portion of your motorhome may be controlled by radio signals produced by the key fob shown below. One characteristic of this system is the one second delay after a pad has been depressed.

NOTE: When you use the keypad to turn the patio lights ON you must also use the keypad to turn them OFF. The same goes for the switch inside the door. . .if you turn the lights on with this switch, you must use the same switch to turn them off. You cannot turn the lights on with the keypad and off with the switch.

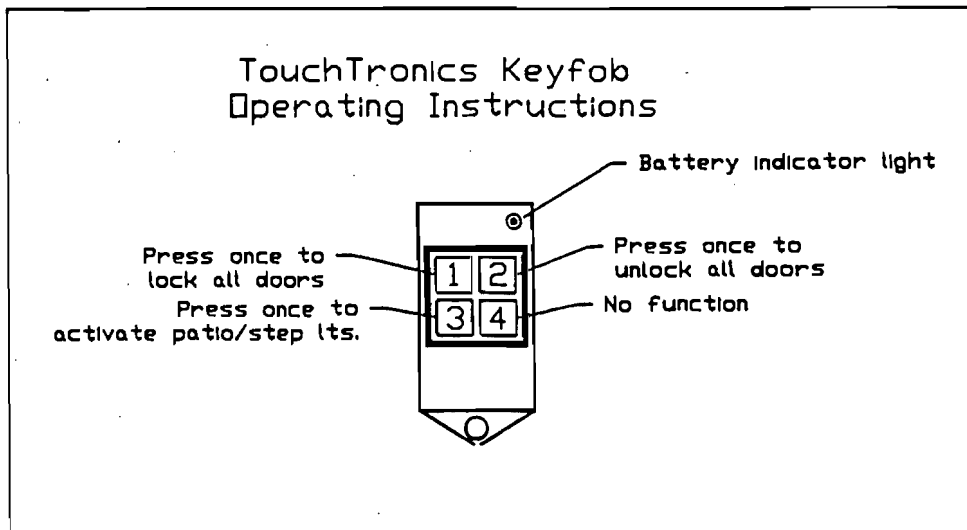

There are four major components operating the door locks; control module/receiver, dash switch, relay, and drive motors. The control module is mounted on the inside wall just behind the main door. The relay operates in conjunction with the dash switch and is located up under the left hand side of the dash. The drive motors, located at each lock, are polarity sensitive. When testing you'll find the wires at the drive motors will switch from positive to negative and vice versus as the key fob or dash switch is being operated. When using the dash switch the relay under the dash performs the polarity switching functions and the control module/receiver serves the same function when the key fob is used.

A detailed wire layout is provided in the electrical section of this manual.

INTERIOR

The luxurious interior of your Airstream motorhome has been designed for comfort, convenience, durability and appearance. An understanding of the operational procedures and maintenance techniques of the interior appointments will add to your pleasures, as well as to the long life of your motorhome.

Lounges

To convert the Deluxe Sofa into a bed, pull the armrest straight up and out of their bracket, grasp the front edge of the seat, raise and pull it toward the aisle of the motorhome. The back rest will slide down into place automatically.

Rear Bed

On diesel models the rear bed is also the engine cover. For access stand the mattress on edge and slide to the front of vehicle. This allows the rear portion to be raised for service.

WARNING: The bed is heavy - - be sure to prop securely!

Dinette

The standard dinette will make into a bed. Swing the table leg up against the bottom of the table, lift up on the front of the table and it will unhook from the wall. Now pull out and the swinging hinge will let the back edge of the table down level with the supports attached to the front of the seat bases. Use back rest to fill in over the table.

Cocktail Chairs

Two operating levers are in the side of the left armrest (as you're seated). One allows the seat to slide forward and back while the other frees the seat so it can be rotated.

CAUTION: Rotating the chair when it's slid back against the wall can damage the upholstery. Position the chair so it isn't chafing when in transit.

Fabric Cleaning

All material should be professionally dry cleaned to remove any overall soiled condition. These materials may be spot cleaned, however, using the cleanability code instructions as listed. Sample swatches are furnished to our dealers. The dealer will be able to give you the cleaning code and part number for the fabrics used in your particular motorhome.

The following are the cleanability code instructions for the various fabrics used in the Airstream motorhomes:

Cleanability Codes

CODE W-S

Fabric care. Spot clean this fabric either with a mild solvent or a water-based cleaning agent. When using a solvent or dry cleaning product, follow instructions carefully and clean only in a well-ventilated room. Avoid any product which contains highly toxic carbon tetrachloride. You may also use an upholstery shampoo product or the foam from a mild detergent. With either method, pretest a small area before proceeding. Use a professional furniture cleaner when an overall soiled condition is reached.

CODE S

Fabric care. Spot clean, using a mild, water-free solvent or dry-cleaning product. Carefully follow instructions on such product. Clean only in a well-ventilated room. Avoid any product containing carbon tetrachloride, which is highly toxic. Pretest small area before proceeding. Use a professional furniture cleaner when an overall soiled condition is reached.

CODE W

Fabric care. Spot clean, using the foam only from a water-based cleaning agent, such as mild detergent or non-solvent upholstery shampoo product. Apply foam with a soft brush in a circular motion. Vacuum when dry. Pretest small area before proceeding. Use a professional furniture cleaner when an overall soiled condition is reached. The above code was designed by the manufacturer of the fabric.

CAUTION: Never remove cushion cover for separate cleaning or washing. Any tumble cleaning method can destroy the backing, shrink or otherwise damage upholstery.

SMOKING WARNING: Keep your furniture and family safe from fires caused by careless smoking. Do not smoke when drowsy. Remove immediately any flowing ash or a lighted cigarette which falls on furniture. Smoldering smoking material can cause upholstered furniture fires.

Drapes

Use the following procedures to remove drapery panels for cleaning:

Front Wrap Around Drapes

1. Remove screws securing drapery track bracket to cabinet, both roadside and curbside.
2. Slide draperies to the rear until they are clear of track.
3. After reinstalling drapes, replace screws in bracket.

CAUTION: All drapery materials and mattress covers must be professionally dry cleaned.

Shades

The day/night shades are opened and closed by grasping both knobs and sliding the shade straight up and down. Your choice of blind density is instantly available by using the appropriate set of knobs.

Carpet

The carpet can be cleaned with any good commercial carpet cleaner, or with a detergent and water. **HOWEVER, BE CAREFUL NOT TO SOAK THE CARPET WITH WATER.**

Hardwood Flooring

To clean hardwood floor use a solution of vinegar and water or Windex.

WARNING: Warn occupants of the vehicle when fresh wax has been applied, just like a home, the floor will be slippery.

Counter areas

The counter areas around the sink are Corian and can be cleaned with soap and water, or you can use a common solvent on tough spots. Be sure no abrasive cleaner is used, as there is the possibility it could scratch the surface. A protective pad should always be placed under hot utensils.

Wall Cleaning

Guilford of Main wall fabrics are color fast to the standard wet and dry cleaning procedures and are also highly resistant to most spot cleaning solvents. The finished fabric would be identified by Standard Care Level S-W. Avoid excessive brushing or rubbing during cleaning practices to prevent fuzzing of the fabric surface.

Because of the very low absorption properties of polyester, soil will tend to remain on the fiber surface and, therefore, is usually removed without need of vigorous treatment. To prevent overall soiling, frequent vacuuming or light brushing to remove dust and grime is recommended. Oil or grease type spots will respond to mild solvent or dry cleaning agents. The blotting technique, without rubbing, should be sufficient to remove most spots.

For general dirt or grime spots, sponging with the foam from a mild detergent or upholstery shampoo should remove the accumulated dirt and grime spot. Room temperature solution should be sufficient. Rinse well with a clean sponge to remove traces of the water base cleaning agent. The fabric will dry very quickly.

When spot cleaning with either the water base or solvent base type cleaning agents, it is recommended to pre-test a small area before proceeding to spot clean the fabric any further.

When an overall soiled condition has been reached, use a professional furniture cleaning service for recommendations in cleaning the fabric.

Drawers

Drawer removal - pull drawer out to stop then raise front of drawer to clear rollers.

CAUTION: Do not use any abrasive material on the vinyl covered walls.

Bathroom

CAUTION: The lavatory bowl and countertop in your bathroom should be cleaned with soap or detergent. NEVER USE SCOURING POWDER.

Shower Stall

To clean your ULTRA/GLAS shower stall unit, use warm water and one of the stronger liquid detergents. Do not use abrasive cleaners; they may scratch and dull the surface of your ULTRA/GLAS unit. Stubborn stains can be removed with solvents such as turpentine, paint thinner or acetone. Restore dulled areas by rubbing with an automotive-type liquid cleaner, then put the soft glow back into your ULTRA/GLAS unit with a light application of liquid wax.

WARNING: Do not wax the floor of the stall without using a bath mat afterward to prevent a dangerous slippery floor condition.

NOTES

PLUMBING

LPG SYSTEM

Your motorhome is equipped with a permanently mounted tank for LPG (Liquid Petroleum Gas). LPG burns with a clean blue flame. There are two basic types of LPG in common usage: Butane and Propane. Butane is widely used where temperatures are normally above freezing the year round, and Propane is used where subfreezing temperatures are common, since Butane freezes at 32°F as compared to -40°F for Propane. ALL OF THE ORIFICES IN THE LPG APPLIANCES ARE OF THE UNIVERSAL TYPE WHICH WILL BURN EITHER FUEL. How long a full tank of gas will last is dependent on usage. In cold weather, when you are using the furnace, large amounts of hot water, and cooking extensively, you will naturally use more than you will in warm weather, when you may do limited cooking. On the average, with normal cooking and other appliance use, you can probably count on one month of usage from the tank.

If you have allowed the tank to run out, air may have gotten into the lines. In this event the air must be forced out through the lines by gas pressure before you can light the pilots. Hold a match to the pilot of the appliance closest to the tanks until it lights and stays lit. Then move to the next closest, etc.

WARNING:

All pilot lights and appliances must be turned off during refueling of motorhome fuel tank and permanently mounted LPG tank. Gas lines should be checked periodically for leaks with ammonia free soapy water. Do not use open flame.

CAUTION:

Moisture in the LPG tank will cause a malfunction of the regulator in controlling proper pressure. This may result in the flame lifting off the burner, or the flame may go out frequently. Many refueling stations will add approximately 1/4 to 1/2 gallon of alcohol to lower the moisture temperature. Moisture will then pass through the regulator without the formation of ice crystals.

WARNING:

If gas can be smelled, appliance pilots fail to stay on, or any other abnormal situation occurs, shut off tank valve immediately and call on a qualified LPG service center or Airstream Service Center.

LPG Regulator

The LPG regulators used on Airstream motorhomes are designed for low pressure service, with a normal outlet pressure setting of 11.5 water column. Only personnel trained in the proper procedures, codes, standards, etc., should service regulators.

Have the regulator inspected each time the tank is refilled. Make sure the regulator vent opening on both first and second stage regulators does not become plugged by mud, insects, snow, ice, paint, etc. Vents must remain open.

Replace any regulator that has had water in the spring case, or shows evidence of external corrosion, or corrosion inside the spring case. Closely examine regulators directly connected to the container valve by means of a solid POL adapter (horizontal mounting) for signs of corrosion. (An Airstream Service Center is recommended for this service.)

BASIC RULES FOR SAFETY

WARNING: DO NOT store LP containers within vehicle. LP containers are equipped with safety devices that vent gas should the pressure become excessive.

WARNING: DO NOT use cooking appliances for comfort heating. Cooking appliances need fresh air for safe operation. Before operation open overhead vent or turn on exhaust fan and open window.

A warning label has been located in the cooking area to remind you to provide an adequate supply of fresh air for combustion. Unlike homes, the amount of oxygen supply is limited due to the size of the recreational vehicle, and proper ventilation when using the cooking appliances will avoid dangers of asphyxiation. It is especially important that cooking appliances not be used for comfort heating as the danger of asphyxiation is greater when the appliance is used for long periods of time.

WARNING: Portable fuel burning equipment, including wood and charcoal grills and stoves, shall not be used inside the recreational vehicle. The use of this equipment inside the recreational vehicle may cause fires or asphyxiation.

WARNING: A Warning Label has been located near the LP gas container. This label reads: DO NOT FILL CONTAINER(S) TO MORE THAN 80% PERCENT OF CAPACITY. Overfilling the LP gas container can result in uncontrolled gas flow which can cause fire or explosion. A properly filled container will contain approximately 80 percent of its volume as liquid LP gas.

WARNING: Do not bring or store LP gas containers, gasoline or other flammable liquids inside the vehicle because a fire or explosion may result.

WARNING:

If you smell gas:

1. Extinguish any open flames, pilot lights and all smoking materials.
2. Do not touch electrical switches.
3. Shut off the gas supply at the tank valve(s) or gas supply connection.
4. Open doors and other ventilating openings.
5. Leave the area until odor clears.
6. Have the gas system checked and leakage source corrected before using again.

WARNING: LP gas regulators must always be installed with the diaphragm vent facing downward. Regulators that are not in compartments have been equipped with a protective cover. Make sure that regulator vent faces downward and that cover is kept in place to minimize vent blockage which could result in excessive gas pressure causing fire or explosion.

LP TANK INSTALLATION

The regulator at the L.P. tank is under a black plastic cover. The protective cover certainly helps to keep the vent on the regulator from getting clogged by wasps or ice, but should still be checked regularly to make sure the vent remains clear.

WARNING: Do not attempt to seal regulator cover.

WARNING: Check vent each time tank is filled to make sure it's clear of obstructions.

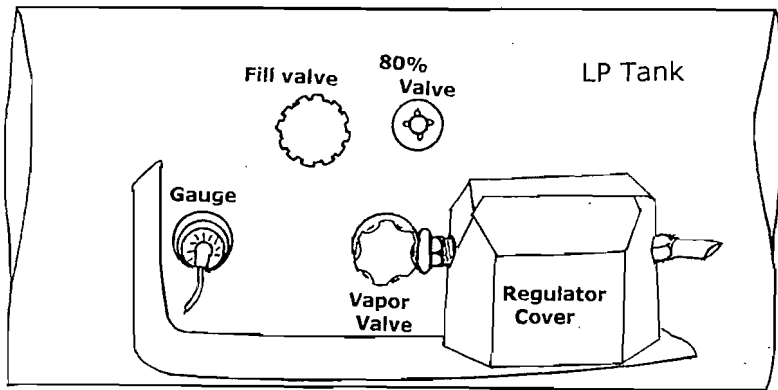

Gas Regulator Removal/Replacement

1. Shut off main gas supply at the tank.
2. Remove the plastic protective cover from the regulator assembly.
3. Using two wrenches, one to hold the line fitting and one to turn the flare nut, disconnect the regulator from the flexible rubber line.
4. Disconnect the regulator from the tank fitting. Remove regulator
6. To replace, reverse the removal procedure.

LET DATE	E.C.N.	REVISION RECORD	BY
A 8/96	4584	PRODUCTION RELEASE	JH

- A. RANGE TOP - MAGIC CHEF 85RB-3BT
17,500 BTU, AGA/CGA, P/N 690348
- B. WTR HTR - ATW000D G6A-6
8,800 BTU, AGA/CGA, P/N 690180
- C. REFRIG - DOMETIC RM 3862
1500 BTU, AGA/CGA, P/N 690370-02
- D. FURNACE - HYDROFLAME 8535
35,000 BTU, AGA/CGA, P/N 690274

TOTAL DEVELOPED LENGTH 29.5'
 TOTAL BTU DEMAND - 62800
 PIPE SIZE DETERMINED BY
 WORST CASE GAS FLOW TEST
 SUPPORT GAS LINES MAX 48"
 PITCH W/ RUBBER LINED CLAMPS.
 RIGID ANCHOR BLACK PIPE WITHIN 6'
 OF BEGINING AND BRANCH ENDS.

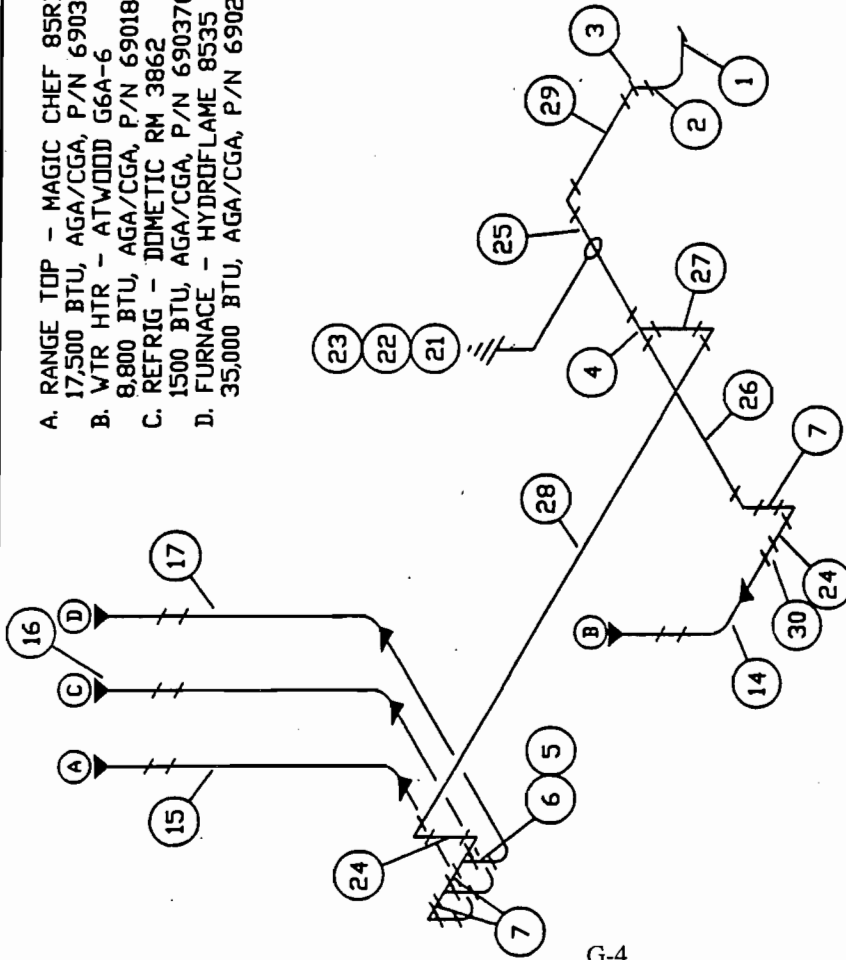

G-4

ITEM	PART NUMBER	DESCRIPTION	QTY	UH
17	600008	TUBING COPPER 3/800 132'	11.0	FT
16	600008	TUBING COPPER 3/800 144'	12.0	FT
15	600008	TUBING COPPER 3/800 108'	9.0	FT
14	600008	TUBING COPPER 3/800 60'	5.0	FT
12	601515	FITTING BRASS 1/4X1/4 INVERT FLAR	1	EA
11	601280	90D BRASS ELBOW 1/4MPT X 1/4FPT	1	EA
10	601277	LP GAS REGULATOR	1	EA
9	201649	ACCESS COVER LP REGULATOR	1	EA
8	452546	BRACKET LP REGULATOR	1	EA
7	601411	1 1/2 MALE ADAPTOR	4	EA
6	600435	FORGED FLARE NUTS 3/8IN	8	EA
5	601412-08	CONNECTOR-M, .50 PIPE TO .38 TUBE	4	EA
4	601409	1/2 TEES	3	EA
3	601408	1/2" 90 DEGREE ELBOW	8	EA
2	601412-12	CONNECTOR-M, .50 PIPE TO .62 TUBE	1	EA
1	601335	HOSE, LP, TANK TO REGULATOR 10'	1	EA

DRAWN BY
JH

APPROVED BY

Airstream

PRODUCT LINE

LP GAS SYSTEM

SCALE	DATE	DRAWING NUMBER	REV.
1=24	06/05/96	B	A

GAS LINES

30	601410	1/2" COUPLING, BLACK PIPE	1	EA
29	601407-24	PIPE STL 1/2 I.D. SCH 40 BLK 24.5	1	EA
28	601407-10	PIPE-STEEL-1/2" ID SCH40 BLK 120"	1	EA
27	601407-31	PIPE 1/2" SCH 40 BLACK 50.00	1	EA
26	601407-25	PIPE STL 1/2 I.D. SCH 40 BLK 36.5	1	EA
25	601407-19	PIPE STL 1/2" SCH 40 BLACK 27.75	1	EA
24	601407-12	PIPE STL 1/2" SCH 40 BLACK 8.00"	8	EA
23	500839	WIRE,BARE COPPER 8 GA.	1	FT
22	500038	LUG GROUND	1	EA
21	600661	GROUNDING CLAMP 1/2 TO 1 SIZE	1	EA
20	380887	GROMMET, FLOOR	4	EA
19	380886	GROMMET, FLOOR	4	EA
18	601279	HOSE LOW PRESSURE 18'	1	EA

WATER SYSTEM - SELF CONTAINED

Most plumbing functions are accomplished in the plumbing utility compartment on the roadside of your motorhome. To fill your water tank, hook up a garden hose to the city water inlet then open the water tank fill valve in the upper right corner of the compartment. The water level can be monitored on your control panel above the range or the tank can be filled until water is expelled out of the tank overflow and is seen running on the ground under the vehicle.

NOTE: Once the water level has reached the height of the overflow, water will continue to be expelled for a few minutes after the fill valve is closed.

If it is more convenient for you, a water fill is also located on the side of the vehicle. Open the small access door, unscrew the cap, pull the air plug, insert hose and fill. The air plug relieves air pressure in the tank as it's being filled. As noted above, water will be expelled from an overflow valve for a short time once the tank is full and the fill hose has been removed.

Turn water heater by-pass valves to normal flow, open valves A and C. Close valve B. For winterizing B would be opened while A and C are closed. Access to the valves is through the cabinet doors under the kitchen sink. Reach to the right. Your valves may be in a horizontal position rather than the vertical illustrated.

Open the hot side of the galley or lavatory faucet and turn on the water pump switch located on the monitor panel. For some time the open faucet will only sputter. This is because the water heater is being filled and air is being pushed out through the lines. Once the water heater is full a steady stream of water will come from the faucet. Now open a cold faucet. It will sputter for a short time, but will soon expel a steady stream. All other faucets can now be opened until all air is expelled.

Once the system is filled with water and the faucets closed, the water pump will shut off. When a faucet is opened the pump will come back on automatically. If the faucet is just barely open it is normal for the pump to cycle on and off rapidly.

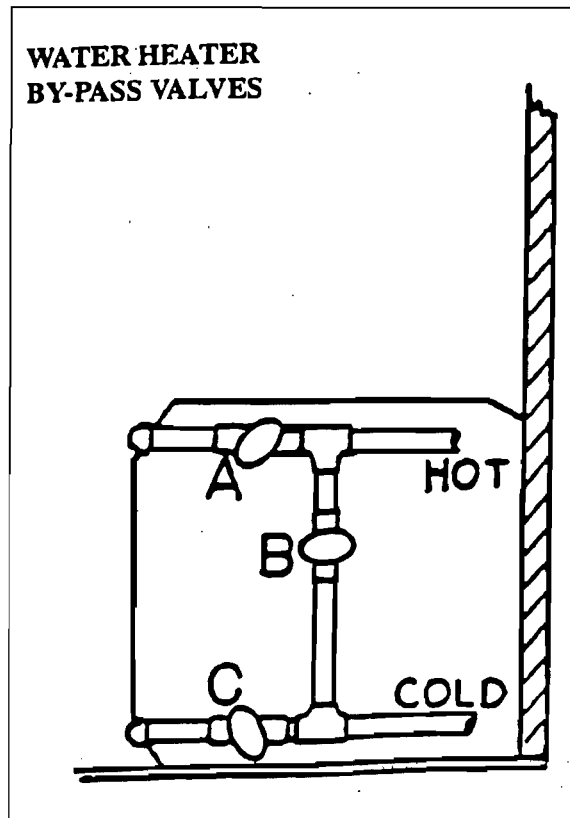

CAUTION: The water pump must be turned off when hooked up to city water supply and when you leave your Airstream unattended.

WATER PUMP AND STRAINER

Water pump access is in the lower exterior compartment on the curbside just in front of the rear wheels. Once the exterior door is raised the pump can be found behind the small access door in the upper right corner of the storage area.

To clean strainer screen, first remove inlet connection from pump side of strainer. This will allow the intake side of the strainer to be rotated about 1/8 turn counter clockwise and removed. The screen part of the strainer will now be accessible for cleaning.

When reassembling, only rotate the inlet side of the strainer until the stops are felt. Sealing is preformed by the "O" ring and too much pressure will only break the strainer.

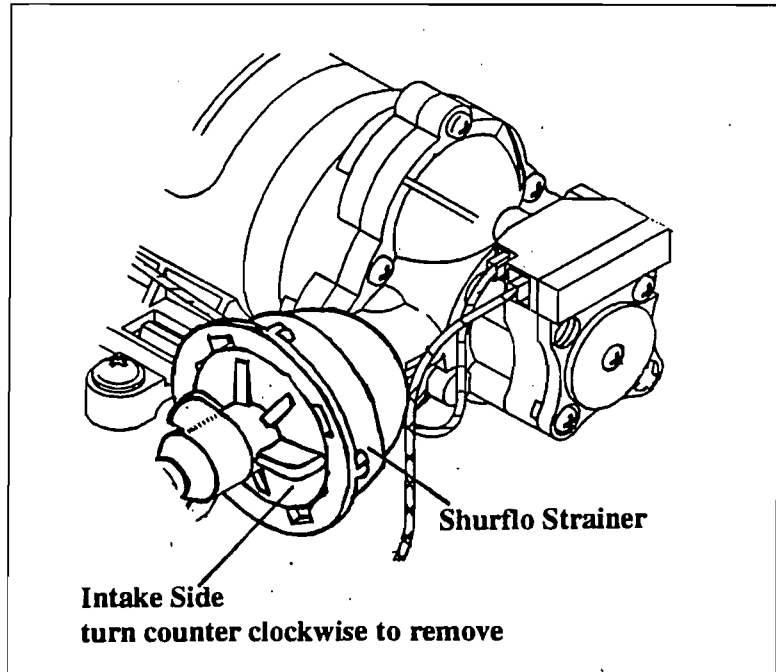

Cleaning Water Storage Tank

1. Prepare a sodium hypochlorite solution using potable water and household bleach (5 1/4 to 6%) in the ratio of 1/4 cup bleach to 1 gallon of water. (Common household bleaches are Purex and Chlorox.)
2. Pour 1 gallon of hypochlorite solution for each 15 gallons of capacity into the empty water tank.
3. Add enough potable water to completely fill the water system.
4. Allow closed system to stand for three hours.
5. Drain the hypochlorite solution from the system and refill with potable water.
6. Excessive hypochlorite taste or odor remaining in the water system is removed by rinsing the system with a vinegar solution mixed in the ratio of 1 quart of vinegar to 5 gallons of water.
7. Drain the system and flush with potable water.

WATER PUMP

Manufacturer:

Shur-Flo
1740 Markle Street
Elkhart, Indiana 46514
Phone: 219-294-7581

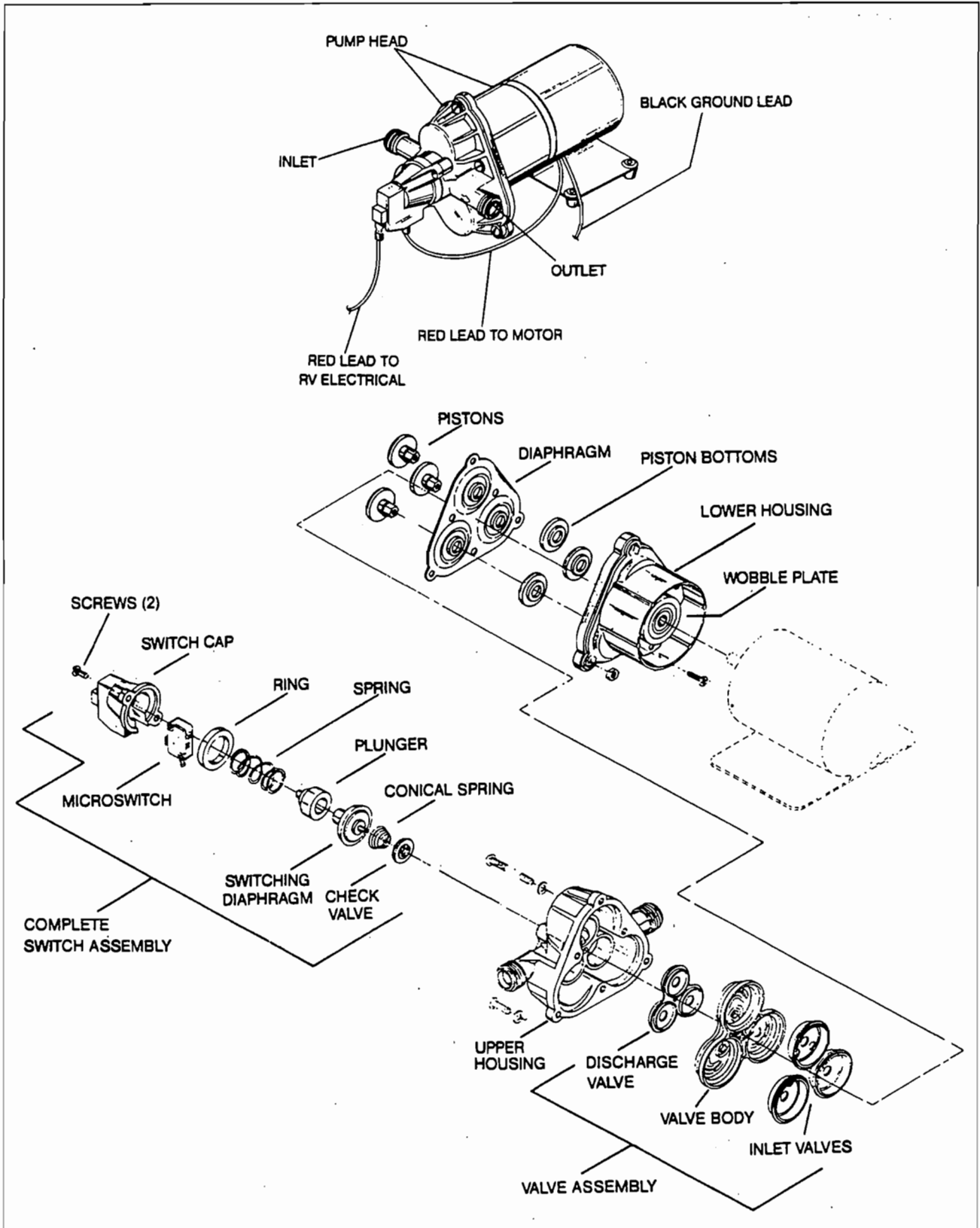

Switch and Check Valve Repair

The check valve, hydraulic switch mechanism and micro switch are accessible by removing the switch cover.

CAUTION: Care should be taken in removing the switch cover screws. Within the mechanism is a spring under compression.

Replacement of Micro Switch

Occasionally the micro switch fails or an electrode is broken off. Proceed as follows: Remove the two screws holding the cap to the main body. Remember, a spring under compression is retained by this cap. With both screws out, allow the spring to extend fully. Then carefully lift off cap and spring. If only the micro switch is at fault, avoid disturbing the hydraulic elements remaining in the head. If examination of the hydraulic parts is required, remove them carefully by pulling. Be sure to note the order of removal.

To replace the micro switch, remove the spring and pull out the black retaining ring. This will allow the micro switch to fall free. Replace parts in the reverse sequence: Micro switch, black retainer, and the spring.

Reassemble cover to the main body. Switch cap may be pointed up or down as desired, providing wire has not been shorted.

Having replaced the micro switch, be careful to rewire correctly.

Note: If the positive wire from the battery is connected to the "B" terminal, the switch is bypassed and the pump cannot shut off. Pressure will build up until the motor stalls. If the proper fuse has been used, it will blow. If a larger fuse than recommended has been used, the motor will stall and may burn out.

Check Valve Problems

Due to contamination from debris or lime build-up, the check valve may fail to properly seat. To correct, clean out the area and replace the check valve element. If checking the check valve with air be certain to moisten the check valve to get an accurate check. The rubber seals more effectively when wet.

Properly Installed, the Pump will:

- PRIME:** The pump will automatically prime itself.
- AIR-LOCK:** Pump will not air-lock as the compression stroke is powerful enough to pressurize the entrapped air and force the check valve open.
- RUN DRY:** Pump will run dry for extended periods without damage.
- BATTERY DRAIN:** At free flow, the pump draws a mere 7 to 7 1/2 amps.
- CHECK VALVE:** Built-in check valve prevents back flow and can protect the pump from the dangers of high city water pressure (up to 200 PSI).
- FULLY AUTOMATIC:** The pump will automatically come on when the faucet or valve is opened. It delivers a smooth, steady flow of water and shuts off automatically when the faucet is closed.

Trouble Shooting

MOTOR DOES NOT OPERATE

- Is battery discharged?
- Are any wires disconnected?
- Are terminals corroded?
- Is switch in "ON" position?
- Is fuse good?
- Is water frozen in pump head?

MOTOR RUNS BUT NO WATER FLOWS

- Is water tank empty?
- Are there kinks in the inlet hose?
- Is air leaking into inlet hose fittings?
- Is inlet line or in-line filter plugged?
- If using a filter, check the line just before the filter.
- Is outlet hose kinked?

MOTOR RUNS BUT WATER "SPUTTERS"

Check to be certain that air has been bled off the lines and water heater. Also check for air leaks in the input side of the pump.

PUMP CYCLES ON AND OFF WHEN ALL OUTLETS ARE CLOSED.

The pump will normally cycle (go on and off) when a faucet is partially opened. If, however, it cycles when all valves are closed, check for a leak in the lines. It may be a leaky toilet valve or a dripping faucet. Do not forget to check the outside city water entry valve. It may be leaking.

If no leak can be detected, shut pump off. Remove the output hose where it joins the system (not at the pump). Insert a plug in the hose and clamp it. (You can make a perfect plug from a barb fitting: 1/2" size with a cap tightly screwed on the threads.) Turn the pump switch on. The pump should come on, run a few seconds, and then shut off. If it remains off, the problem is NOT the pump. The problem is in the system. If, however, the pump goes on and off, there may be a problem in the pump.

There may be an internal leak in the pump which allows water to escape from the high pressure area back into the low pressure area. Look for a pump valve held open or a crack in the plastic parts.

PUMP DOES NOT ACHIEVE SHUT OFF

The wall switch may be used for temporary control of the pump. A low battery charge may be the cause. Or the pump switch mechanism may be stuck. Try tapping the switch cap on the end of the pump with the handle of a screwdriver. If the pump appears in all other respects to run normally, but fails to shut off, you may have to replace the switch mechanism.

PUMP HEAD LEAKS

If the pump head leaks, first try to tighten the screws in the pump head assembly until they are snug.

CAUTION: Do not over tighten. The leak may be from a crack in the pump head assembly. If so, then replace.

One cause of the pump head cracking may be water freezing inside the pump head. If the leaking water is escaping back near the motor, check for a leaking or broken piston.

Pump Repair

Screws (A) hold the entire pump head assembly to the motor.

Screws (B) hold the pump head face to the pump head main body.

Screws (C) hold the switch assembly to the front of the pump head.

Screws (A) would be removed to correct a problem in the "drive train" between the motor and pump head.

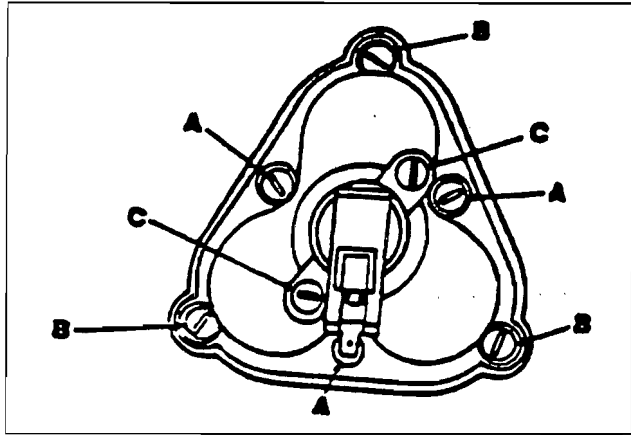

Screws (A) and (B) would be removed to correct a problem in the pump head valves or pumping chambers.

Screws (C) would be removed to correct a problem in the automatic switch or check valve.

PUMP HEAD REPAIR

Motor and drive train area. Rarely does a problem occur in this area of the pump head. If a part does fail, it is quite easily replaced. Just be certain to follow closely the sequence of parts as shown in the figure. Also be careful to align the flat surface in the drive adapter with the flat surface on the motor shaft.

LUBRICATION

If the lubricant appears dried out it should be wiped off the bearing assemblies. A small amount of automotive wheel bearing grease should be applied to both sides of each bearing.

FAILURE TO PRIME

Failure to prime can be caused by the presence of some foreign matter lodged in the valve preventing it from seating. To correct, remove any such foreign bodies.

CAUTION: Do not remove the stainless steel screens. These filter screens should be cleaned without removing them from the plastic housing.

PUMP CHAMBER REPAIR

Replacement of broken piston.

To remove a piston, back out the screw holding the defective piston.

Now lift the corner of the diaphragm and remove the broken piston. Insert the new piston through the diaphragm and slide the retaining ring on. Rotate the piston until it drops into place in the drive plate. Replace the screw and tighten until snug.

CAUTION: Do not attempt to re-use a piston once it has been removed. The plastic stem, if used a second time, may not hold securely. The second thread path removes additional material and there is then no real bite.

REPLACE A DIAPHRAGM

To replace a diaphragm follow the procedure used in removing the pistons. After removing the three pistons the diaphragm is loose and easily removed.

Screws (A) hold the piston.

Screws (B) hold the drive mechanism and should not be removed when replacing piston.

CITY WATER HOOKUP

In your utility compartment on the roadside of the motorhome is the city water hose connection and various other valves. They are clearly marked and the functions of each should have been explained by your dealer at time of purchase.

NOTE: When you use the "fresh water tank fill" valve and fill the tank it will expel any overflow under the coach. When you turn the fill valve off, the overflow will not cease immediately, but will slowly taper off.

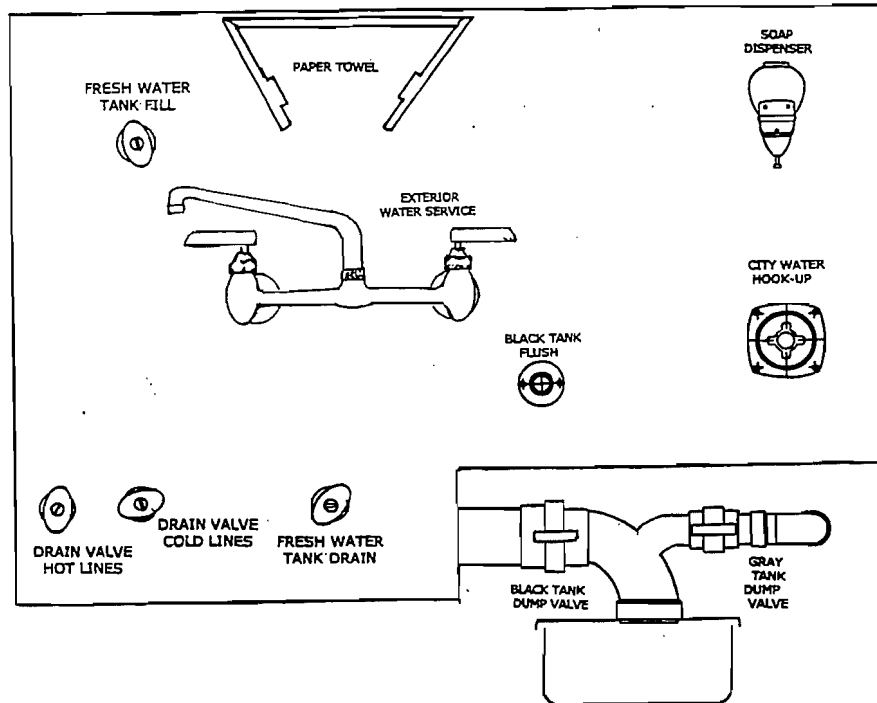

Use a high pressure hose of at least 1/2" diameter. It should be one that is tasteless, odorless and non-toxic designed for RV use. The city water inlet is a standard garden hose thread. We suggest you carry two lengths of hose. This way you have the ability to reach hookups further away than normal, plus you have a spare hose should one fail or become damaged unexpectedly. Turn the water heater bypass to the normal flow position as described under self contained.

After hooking up the hose and turning on the city water valve provided in the park, slowly open a faucet. There will be a lot of spurts and sputtering until all the air is expelled from the motorhome system. If the water heater is empty it will take some time before all the air is expelled and you get a steady flow of water at the faucet. Once a steady flow is achieved at one faucet the others should be opened long enough to expel the air in the lines going to them.

During city water operation the water pump switch should be in the off position. A check valve built into the pump protects it from city water pressure.

Your plumbing system has a built in pressure regulator to protect your lines and faucets from extremely high pressures on some city water systems.

Information on dump valve and black tank flush use can be found under DRAIN AND WASTE SYSTEM further back in this section.

EVERPURE WATER FILTER

The filter is located under the galley sink. It will remove even very fine dirt and colloidal matter, and eliminates most chlorine, phenol and similar distasteful odors and tastes, while delivering sparkling taste-free water for drinking and cooking. The filter is connected to the cold water galley drinking faucet only. The filter will also remove iron and sulphur provided the water supply is chlorinated. super-chlorination will precipitate the iron and sulphur which will then be removed by the QC-2 Filter. To purify any questionable water fill the Everpure Chlorine Disinfectant Dispenser with liquid bleach and add 1/6 ounce (one teaspoonful) per 10 gallons of water in the water tank. The water will remain sparkling clear even to the end of the filter pack life, however, as the minute pores slowly fill up with impurities the flow rate will be gradually reduced. When it becomes too slow for convenience the cartridge can be very simply changed. Follow the instructions on the cartridge. We advise keeping a spare cartridge at all times.

To Remove Used Cartridge:

1. Shut off water by lifting valve handle counterclockwise as far as possible.
2. Turn colored ring all the way to the left. Ring will drop about 5/8".
3. Lift cartridge slightly and turn it further to the left until it can be disengaged.
4. Lower cartridge to disengage it from ring. Discard used cartridge.

To Install New Cartridge:

1. With colored ring in lowered position (turned all the way to the left), orient lug on cartridge with cutout under label on ring.
2. Insert cartridge straight up into ring as far as it will go. Holding colored ring steady, turn cartridge as far to the right as possible, without forcing.
3. The turn colored ring far to right to drive cartridge up into head.
4. To lock ring in place and turn water on, move valve handle down. Be sure handle leg engages ring locking-lug.

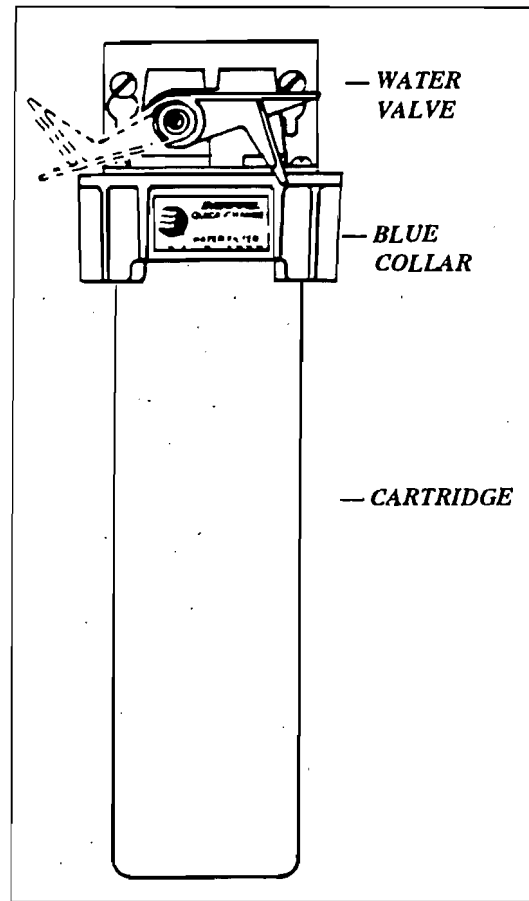

Everpure Water Filter

FAUCETS

Care and Cleaning

The surface of the faucets will stay bright and resist wear with a minimum of care. Strong detergents may tend to dull the finish. So when cleaning a faucet use only mild soap and water.

The finish on the faucets has been designed to retain its polished appearance without scouring. Stains and dirt remove easily without the use of scouring powders or abrasive polishes and cleaners. Use of such agents may cause scratches which mar the finish, and in time become dirt catchers and unattractive.

MOEN FAUCET CARTRIDGE REPLACEMENT

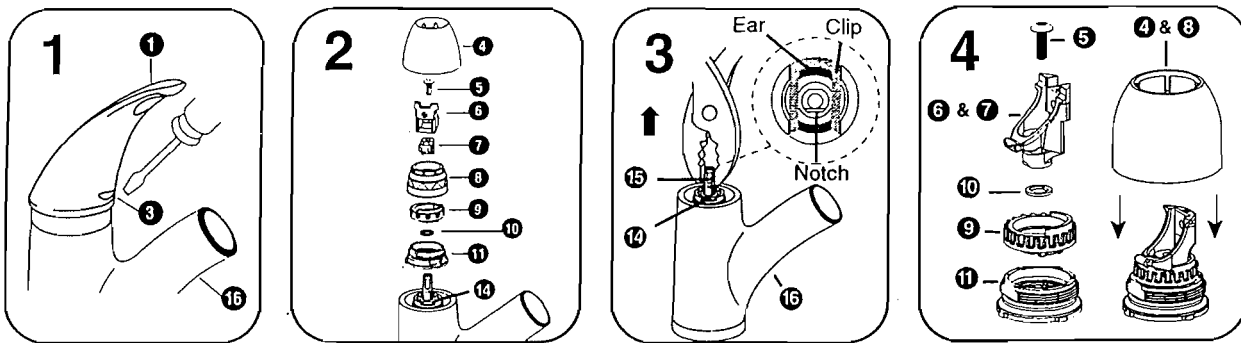

CAUTION: Always turn water OFF before removing existing faucet or disassembling the valve. Open faucet handle to relieve water pressure and ensure that complete water shut-off has been accomplished.

1. Remove plug button (3) from the handle by prying the button upwards from the bottom center. Be careful not to scratch the handle. Lift the handle up and using a 7/64" hex wrench, remove set screw (2). Remove handle (1), unscrew dome and pivot retainer (4 & 8), cartridge screw (5), handle adapter & connector assembly (6 & 7), pivot stop (9). Remove DD washer (10) and retainer nut (11).
2. Using a flathead screwdriver, remove the retainer clip (14).
3. Grasp cartridge stem with pliers and pull cartridge (15) straight up and out of valve body.
4. Reinstall as follows: Install cartridge (15) into valve body with notched flat on stem facing forward. Be sure to position the ears of the cartridge in the front and back. Reinstall the retainer clip (14), which straddles the ears on the cartridge. Reinstall the retainer nut (11) and pivot stop (9) with the stop in front as shown in Step 4 above. Reinstall DD washer (10) and reassemble handle connector and handle adapter (6 & 7). Note orientation of this sub-assembly as shown in Step 4. Install cartridge screw (5). Be sure to install completely to prevent unwanted closure of faucet. Thread on dome and pivot retainer (4 & 8) clockwise until hand tight. Reinstall handle (1), set screw (2), and plug button (3).

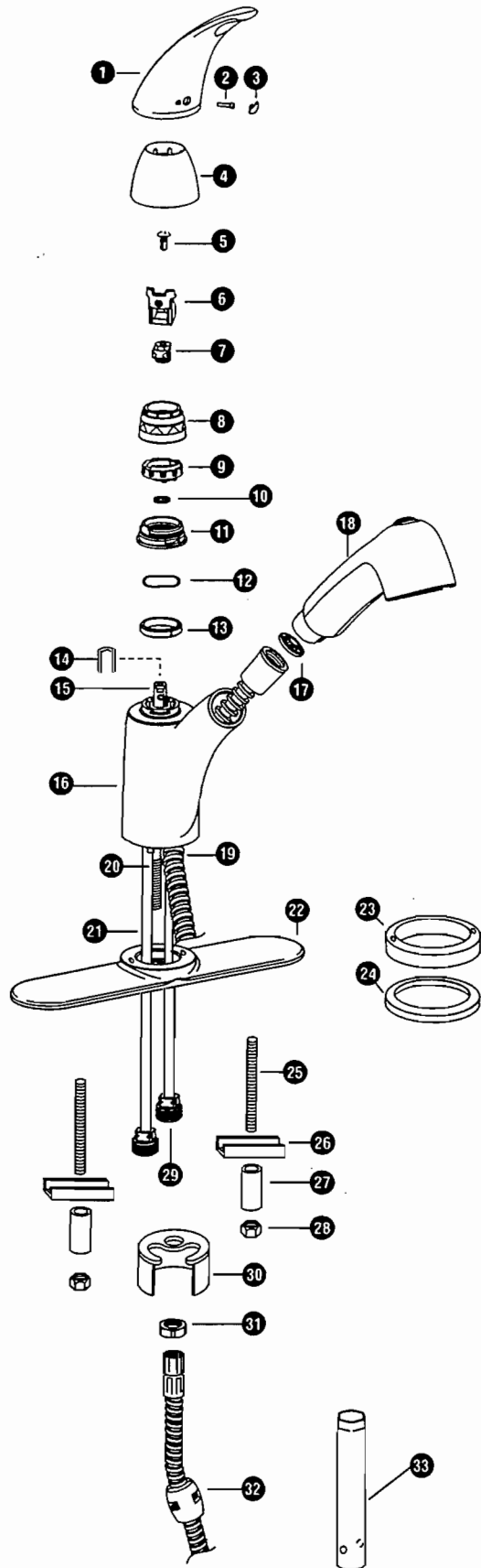

1. Handle
2. Set Screw
3. Plug Button
4. Dome
5. Cartridge Screw
6. Handle Adapter
7. Handle Connector
8. Pivot Retainer
9. Pivot Stop
10. Double D washer
11. Retainer Nut
12. Wave Spring Washer
13. Bearing Washer
14. Retainer Clip
15. 1225 Cartridge
16. Spout Receptor
17. Screen Washer
18. Pull-out Spout
19. Hose
20. Threaded Discharge Tube
21. Supply Tubes (2)
22. Deck Plate
23. Deck Ring
24. Deck Ring Gasket
25. Deck Plate Studs (2)
26. Clamp Bar (2)
27. Spacer (2)
28. Small Mounting Nut (2)
29. 1/2" Threaded Fitting (2)
30. Mounting Bracket
31. Medium Mounting Nut
32. Counter Weight
33. Mounting Tool
34. Large Mounting Nut (2) (not shown)

LAVATORY FAUCET, MOEN

DISASSEMBLY:

CAUTION: Turn OFF BOTH water supplies and open BOTH faucet handles to relieve water pressure and to insure that COMPLETE water shut off has been accomplished..

1. Remove handle cap or plug button (for Concentrix handle models unscrew handle cap), handle screw, handle hub (insert handle adapter for Concentrix models).
2. Loosen the cartridge nut with an adjustable wrench and remove it and the stem guide as a unit together with the upper handle adapter.
3. Set aside the cartridge nut and stem guide and with the handle adapter installed, reassemble handle hub (insert handle adapter for Concentrix models) and handle screw and tighten.
4. Grasp the handle hub (insert handle adapter for Concentrix models) and pull the cartridge STRAIGHT UP and out of the valve body.

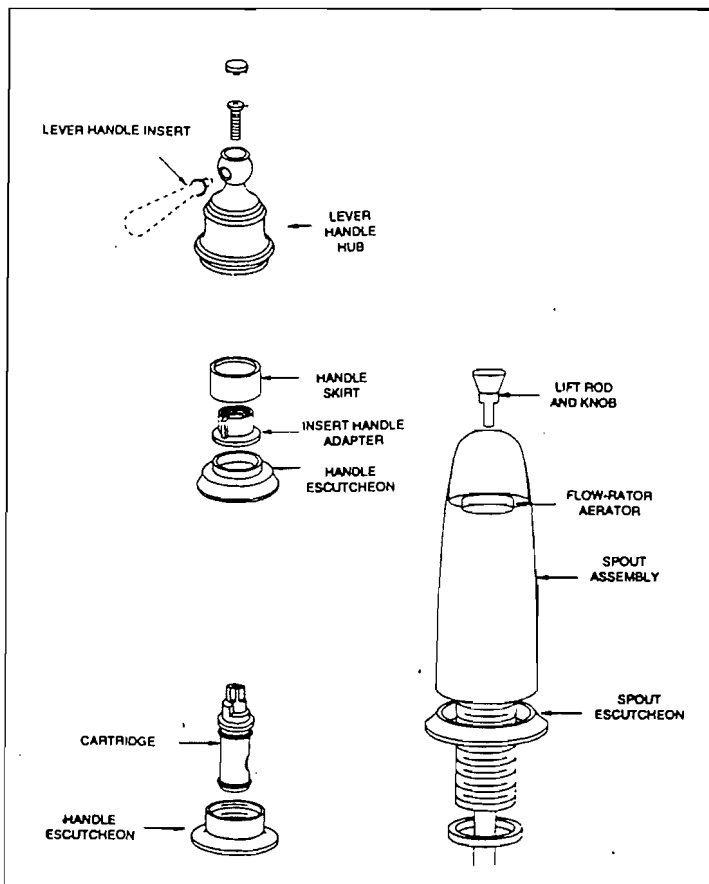

REASSEMBLY:

CAUTION: Failure to follow these instructions can cause personal injury or water damage to the premises, or could result in a faulty installation or damage the new cartridge.

1. Assemble upper and lower handle adapter and the handle hub (insert handle adapter for Concentrix models) to new cartridge with the handle screw. Turn stem to the ON position, waterway holes in cartridge are lined up.
2. Insert the cartridge straight into the valve body, press firmly while rotating the handle hub (insert handle adapter for Concentrix models) counterclockwise until you feel the key enter notch in the valve body. This will correctly position the cartridge. Turn handle knob in both directions to insure a stop in each direction.
3. Note handle rotation and orientation if adjustment is required.
4. Remove handle screw and handle hub (insert handle adapter for Concentrix models), install cartridge nut with stem guide over the upper handle adapter, start by hand DO NOT CROSS THREAD. Firmly tighten cartridge nut and stem guide using adjustable wrench.
5. Replace handle parts. Turn on water supplies.

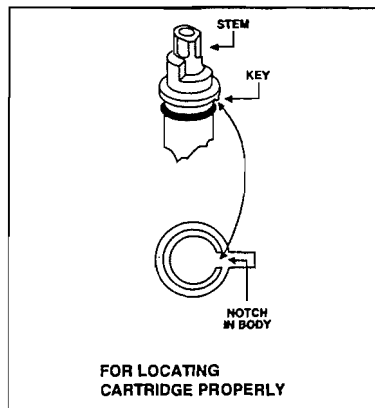

MOEN SHOWER MIXING VALVE ASSEMBLY

1. Handle Cover
2. Handle
3. Cartridge
4. Handle Screw
5. Valve Body
6. Stop Tube
7. Retainer Clip

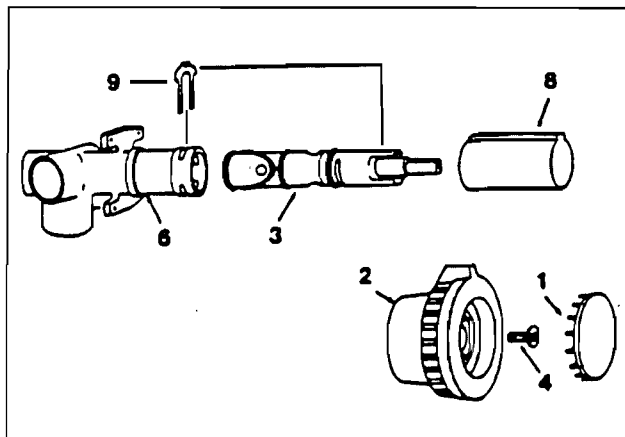

SHOWER MIXING VALVE CARTRIDGE REMOVAL

Shut off water pressure for entire system.

Disassemble: Remove handle cover. Take out handle screw and remove handle and stop tube. Lift out retaining clip and pull the cartridge out of the body by the stem.

CAUTION: Reinsert cartridge by pushing it all the way into the body and until the front of the ears on the cartridge shell are flush and aligned with the body. Replace the retainer clip so that the legs straddle the cartridge ears and slide down into the bottom slot in the body. This prevents the cartridge from rotating and locks it in the body. Reinstall stop tube and handle. Tighten handle screw securely, and replace the handle cover. The red flat on the stem must point UP when mounting the knob handle (down for lever handle).

If cold water is on left side and hot water is on right side (red flat pointed down), remove cartridge and reinstall 180°.

Removal and Replacement

1. Cover carpet and cover bottom of shower pan to protect them from damage.
2. Disconnect city water. Shut off water pump.
3. Open drain valves
4. Open galley, lavatory and shower faucets and allow water to drain from lines.
5. Remove screws from top of faucet inspection cover in wardrobe. Tip back and remove water lines from faucet.
6. Pop out metal insert in control valve handle. Remove screw and pull knob off.
7. Remove screws in escutcheon plate.
8. Disconnect shower hose.
9. Wrap masking tape on chrome fitting so as not to scratch chrome.
10. Using wrench, remove fitting.
11. Mixing valve, shower outlet, tube and hot and cold feed line assemblies may then be removed through wardrobe inspection hole.
12. Replace by reversing above procedure.

NOTE: If existing hose clamps were destroyed in removal, they should be replaced with screw type clamps.

STORAGE AND WINTERIZING

When storing your motorhome for a short or long period, use the same precautions as you would in your own home in regard to perishables, ventilation and rain protection. In addition, for prolonged storage periods, flush out all the drain lines and the holding tanks. Also, drain the entire water system, including the water heater and the water storage tank. Instructions for draining the water system are explained in the following paragraphs on winterizing.

Twice a year, or after a long storage period, we suggest you take your unit into your Airstream dealer for a check-up and cleaning of the gas operated appliances

Living Area

The main consideration in winterizing is to guard against freezing damage to the hot and cold water systems, the waste drain system (including the traps), the waste holding tanks, the water heater and the batteries. To completely winterize your motorhome follow this procedure:

1. Level the motorhome from side to side and front to rear. Open all faucets.
2. Turn the water pump switch to the OFF position.
3. Open the two line drain valves in your utility compartment as well as the exterior water service faucet. Open water tank drain valve also located in the utility compartment. Remove plug or open petcock on exterior face of water heater.
4. The toilet water valve should be left in open position while draining water.
5. While the water is draining from the system, depress the button on hand spray heads and drain all the water. Unscrew the heads on spray units and store. Don't forget the exterior water service.
6. After the water has stopped running from the drain lines, apply at least 60 lbs. of air pressure at the city water inlet. Be sure the toilet valve and all drain valves and faucets are open and pump outlet hose is disconnected. This can be accomplished at a service station and will force any remaining water from the water heater and remove any water which may be trapped in low areas.
7. Pour a cup of non-toxic antifreeze into the lavatory, sink, and tub drains to prevent freezing water in traps.
8. Be sure to open the waste holding tank drain valves, and drain and flush the tanks thoroughly. (This is very important, as the sewage in the tank, if frozen, could seriously damage the tank.)
9. Remove water filter canister and dump.
10. Remove the batteries from your motorhome and store in a cool dry place where there is no danger of freezing. It is very important for optimum life of your battery to check it periodically and to keep it fully charged. This is especially true in winter months, when the temperature may drop below freezing.

Please refer to the battery section for more information on battery maintenance.
11. Remove any items (food, cosmetics, etc.) from the interior that might be damaged by freezing, or might damage the motorhome if containers break.

For additional winterizing protection, add non-toxic antifreeze (approved for drinking water systems) to your water lines using the following procedure:

1. Reconnect all lines except the hose to the pump inlet port. Close all drain valves (See Step 3).
2. Turn bypass valves to bypass position. Close A & C, open valve B.
3. Attach a length of hose to the pump inlet port. This piece of hose should be long enough for the free end to be inserted into and reach the bottom of the antifreeze container.
4. Dilute the antifreeze solution in accordance with the manufacturer's instructions.
5. Open all water faucets.
6. Insert hose length into the antifreeze container, turn the pump switch on, and run the water pump until the antifreeze solution fills all water lines. Flush toilet. Work shower hand spray while holding down in tub.
7. Shut off the pump and close all faucets.
8. Disconnect the hose length from pump inlet fitting and reconnect water system inlet line.

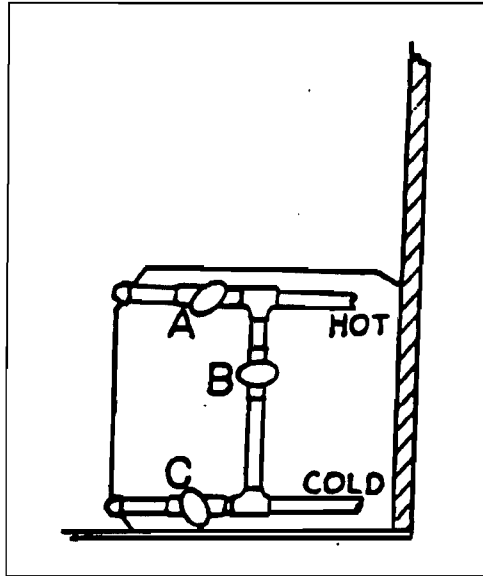

*To by-pass the water heater for winterizing, close valves A and C and open valve B (See illustration).

DRAIN AND WASTE SYSTEM

The drain and waste system of your motorhome includes waste holding tanks made from molded plastic. The MAIN HOLDING TANK enables you to use the toilet for several days away from disposal facilities. The waste water from the sink, shower, and bath and lavatory drain into the AUXILIARY HOLDING TANK. Each tank has its own dump valve; however, both tanks drain through a common outlet. Therefore, you need to make only one connection when hooking up in a trailer park with sewer facilities.

Monitor Panel

Check your monitor panel frequently. When the MAIN HOLDING TANK (tank 1) is completely full, sewage cannot be emptied from the toilet bowl. If the AUXILIARY HOLDING TANK (tank 2) is overfilled, drain water will "backup" into the tub and cause an unpleasant cleaning job. Never drain the tanks at any place other than an approved dumping station.

To empty both tanks, attach the sewer hose by pressing the bayonet fitting onto the outlet adapter and rotate clockwise until it feels solid and secure. Attach the outlet end of the hose to the sewage outlet, making sure that the hose is placed so that it will drain completely. The dump valves are located in the utility compartment on the roadside. Pull the dump valve handle out as far as it will go and wait until the tank is drained. If the auxiliary tank is drained after the waste tank, the soapy water will help keep the sewer hose and outlet clean.

When Parked and Connected to Sewer Outlet

When you are in a park and connected to a sewer outlet, keep the main holding tank dump valve closed, and empty the tank every few days or whenever it becomes almost full. **ONLY BY SENDING A LARGE VOLUME OF LIQUID THROUGH THE MAIN HOLDING TANK AT A TIME WILL TOILET PAPER AND OTHER SOLIDS COMPLETELY WASH AWAY.**

This practice will avoid the accumulation of solids in the main holding tank, which could lead to an unpleasant cleaning job. Should solids accumulate, close the dump valve, fill the tank about half full with water, then drive the motorhome for a few miles. The turbulence and surging of the water will usually dissolve the solids into suspension so the tank can be drained. Keep the auxiliary tank valve open when connected to a sewer outlet.

Draining the tanks as described will protect them from freezing during storage. When traveling in sub-freezing temperatures, use a winterizing solution designed for RV use. Follow the directions on the container.

CAUTION: Never put wet strength paper towels or tissues in your holding tank, since they won't dissolve and can "catch" in the mechanism of the dump valve. Colored toilet tissue is slower to dissolve than white. Most RV accessory stores offer tissue, designed for RVs, that will completely dissolve.

BLACK TANK FLUSH

The main holding tank must be flushed out until all paper and waste material is removed. Close the dump valve and refill the tank with 5 to 10 gallons of clean water and repeat until clean.

In the utility compartment on the left side is a water hose connector marked "black tank flush." To use, hook-up hose and turn on full force. Within the tank a spray head with a multiple-holed head will spray the interior surface of the tank.

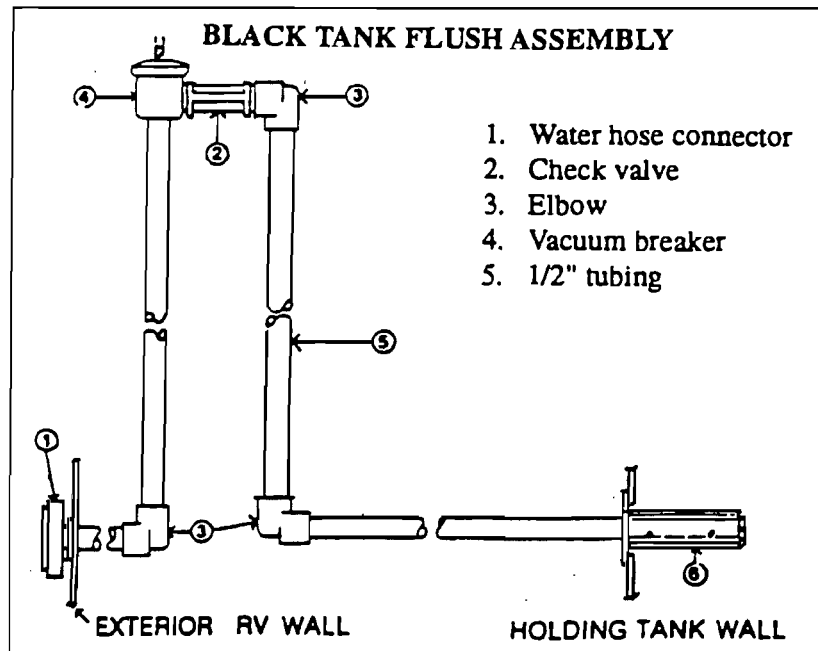

The gate valve should be closed for the first couple of minutes, then opened to let the water out in a rush. Repeat as needed.

Drain Systems Cleaning

There are many deodorizers on the market in tablet, liquid, and powder form. These not only combat odor, but stimulate the bacteria that works to dissolve the solids in your tank. Picking a deodorizer with lubricating qualities will ease slide valve operation.

The only cleaning agents that can be used without causing harm to the system are household ammonia and trisodium phosphate in small quantities. Do not use any product that contains any portion of petroleum distillates. This attacks the rubber seals of your toilet and dump valve. Also, do not use any dish detergent or abrasive cleaners. All products should be marked approved for ABS drainage systems.

When winterizing drains use only recreational vehicle plumbing type antifreeze. These are sold through your dealer.

TOILET

Manufacturer: Thetford Corporation
7101 Jackson Road
Ann Arbor, MI 48103
313-769-6000

The RV toilet in your Airstream is a design that has been used for many years. There are two pedals. The large pedal opens and closes the slide mechanism, and the smaller pedal opens and closes a water valve.

In normal use, when you are hooked up to city water, both pedals are depressed together. This dumps the sewage and fresh water and flushes down the side of the bowl. Water will continue to run into the bowl for a short time after the pedals are released.

When you wish to conserve water, hold the handspray head over the bowl and hold down the thumb-operated lever. Now, when you depress the pedal, all the water is routed through the handspray.

CAUTION: When you dump the bowl of the toilet, make sure all paper and solids have cleared the slide mechanism before you allow it to close. Failure to do so can cause the groove for the slide to become jammed, and the slide will no longer close completely.

If the problem should occur, a small nail or bent clothes hanger can be used to "pick" the material out of the groove.

NOTES

ELECTRICAL SYSTEM

12 VOLT SYSTEM

BATTERIES

Your motorhome is equipped with six batteries. Two batteries will be for the engine and the other batteries for the interior 12 volt circuits.

Engine Battery

The engine batteries are used for starting the engine and operating the headlights, tail-lights, running lights, instrument panel lighting, automotive air conditioning and other accessories. The engine batteries are charged by the alternator while driving and are located in the curbside rear lower compartment.

Coach Batteries

The coach batteries are used for interior lighting, exhaust fans, generator, water pump, central control panel, entertainment center, optional 12-volt convenience outlets, and the refrigerator when it is switched to 12-volt power. These batteries are charged by the engine's alternator when driving, or by the converter when plugged into 120 volt city power. They are also charged by the generator, when it is running, through the 120 volt city power system. They are located in a lower rear compartment on the curbside.

Auxiliary Battery Switch

The switch marked aux. batt. on the panel just inside the main door acts as a master switch. When turned off it opens the circuit between the coach batteries and the twelve volt distribution panel. The component that actually makes and breaks the circuit is a large continuous duty rated solenoid located in the front compartment next to the batteries.

The switch is not intended for everyday use. But if you're going to be away from your coach for more than 3 or 4 days and it's not plugged into 110 volt current just flip the switch off on the way out and your assured of fresh batteries when you return.

Inverter

With the inverter is the standard package of four batteries for the interior coach circuits. The inverter is located in the second lower compartment back of the main door. An inverter uses 12 volt battery power and changes it to 120 volt AC current. More information on the 120 volt operation is in the 110 volt section of this manual.

What is important on the 12 volt side is the amount of power required from the batteries for the inverter. This is probably best shown by a little ninth grade science.

120 Volt (Plugged in)	12 Volt (Battery power)
$\frac{1500}{120}$ Watt = 12.5 amp	$\frac{1500}{12}$ Watt = 125 amp
120 Volt	12 Volt

Pulling 125 amps from your batteries is a tremendous load. Luckily there would probably be few times where you need this kind of power. If you do need 1500 watts for an extended period of time start your generator - - - 1500 watts would be a light load for it.

A little common sense will make the inverter system useful. But, if you try to overdo it you'll have dead batteries.

Interior Lights & Switches

Many interior lights have been included in your motorhome to give you almost infinite variable light intensity.

Just inside the main door are switches for the step, patio light, aux. batt., and forward ceiling lights. The forward ceiling lights must have their switches on before the remote switch on the panel will control them.

In the bathroom the water heater switch supplies power to the ignitor and gas valve. When turned on, it will flash red until flame is sensed, then the red light will be extinguished.

The bulbs in the interior lights are all easily replaced if they burn out. Round, exposed bulbs, such as those around the bathroom mirror and reading lights, are replaced by depressing them into their base, then turning to the left about 1/4 turn. This will allow them to "pop" out part way, so they can be removed. Twelve volt bulbs with flat bases pull straight out of their socket.

To gain access to the bulbs in the round reading lights recessed in the bottom of the overhead lockers you must remove the lens. The lenses are removed by turning counterclockwise about half a turn. The bulb, like other flat base bulbs, pulls straight out of the socket.

WARNING: If they are difficult to turn, use a folded rag to protect your hand when grasping the bulb in case it should unexpectedly shatter.

The ceiling and wardrobe light lenses are removed by squeezing the sides of the lens in until they clear the frame. In cold weather it is helpful to leave the light on for a while to soften the plastic and avoid cracking. Incandescent bulbs are removed by depressing and turning to the left about 1/4 turn. Fluorescent bulbs are removed by turning in either direction.

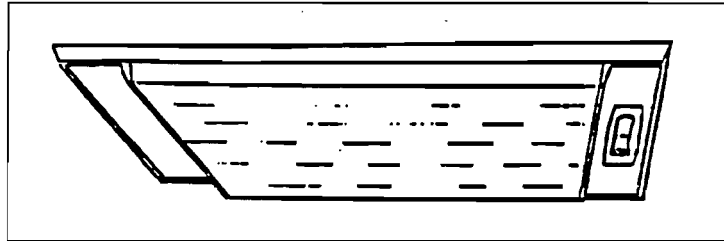

12 Volt Operation

The switch just inside the door marked "aux. batt." or just "batt." is the main 12 volt kill switch. Anytime you are using the coach, leave this switch "on".

The only thing you have to do is make sure the coach batteries don't run down. In normal usage there isn't any problem, since you would normally drive part of the day and be plugged into a camp ground at night. The alternator charges the batteries when you drive and when you're plugged into city power the convertor charges the batteries and carries much of the load.

Some nights you may not find a place to plug into city power. No problem; the standard battery system gives you about 400 amp-hours so you can comfortably run your lights and vents in a normal fashion without depleting the batteries.

If you are not plugged into city power and you're not driving, you'll want to conserve your batteries by using as few lights and appliances as possible. If you notice the lights becoming dim, it's much easier on the batteries if you go ahead and start the engine or generator before the batteries run down.

Your motorhome is equipped with a 10 watt solar panel. There is an indicator light to the left of the micro that is on when there is enough sunlight to have a charging condition.

There are two sets of 12 volt fuses and breakers in your motorhome. The main interior circuits are in the foot of the bed behind an access door. The brightly colored fuses pull straight out from the face of the panel. Replacement fuses are available at automotive stores and most service stations. On the panel covering the fuses is a diagram showing the function of each fuse or circuit breaker.

The second set of fuses are the ones provided by the chassis manufacturer. Freightliner fuses are located in the lower compartment forward of the roadside front wheel.

Basic 12V Wiring

On the following pages are 12-volt wiring diagrams. The first drawing simply labeled "12V Wiring" will probably be the most useful. It shows how the power from the batteries reaches the main components.

All the batteries are located in a lower compartment behind the curbside rear wheels.

12V WIRING DIAGRAMS

- 12 volt wiring, main
- Harness, head light
- Harness, firewall
- Harness, chassis components
- Harness, body, chassis-A
- Harness, body, chassis-B
- Harness, A pillar
- Harness, switches, arm rest
- Harness, clearance lights
- Harness, body, interior -A
- Harness, body, interior-B
- Harness, body , upper
- Harness, ceiling
- Harness, taillight extension
- Harness, taillight
- Harness, rear clearance lights
- Wiring, exterior mirrors
- Wiring, slide-out room relays
- Wiring, coax cable
- Wiring, keyless entry

952581

CONTROL PANEL GEN. START SWITCH



- 18 GA. YELLOW, START
- 18 GA. RED, METER/GEN. RUN
- 18 GA. BLACK, GROUND
- 18 GA. BROWN, STOP

H-4

12 BROWN - CIR. 4

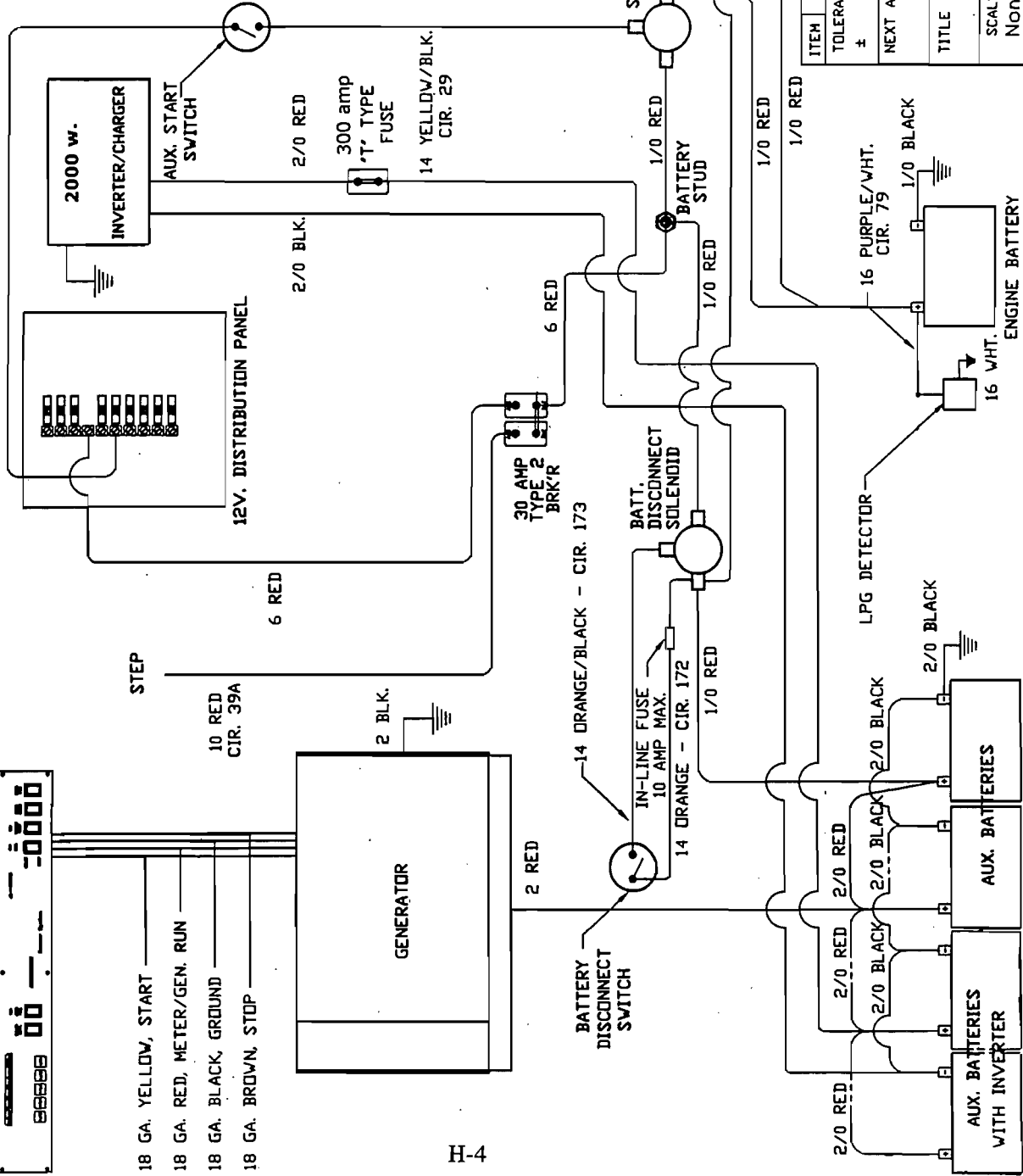

LET	DATE	E.C.N.	REVISION RECORD	BY
	9/96	*	Production Release	RA

ITEM	PART NUMBER	DESCRIPTION	QTY
TOLERANCES			
±			
NEXT ASSY			
TITLE 12V. Wiring			
DRAWING NUMBER 952581			
PRODUCT LINE Mh.			
SCALE	DATE	DRAWING NUMBER	REV.
None	09/20/96	952581	B

DRAWN BY
R.L.A.

APPROVED BY

- = 20 Ga. Wire
- = 18 Ga. Wire
- ◇ = 16 Ga. Wire
- △ = 8 Ga. Wire
- = 14 Ga. Wire
- ◇ = 12 Ga. Wire
- △ = 10 Ga. Wire

CAVITY CIRCUIT	
A	25
B	112
C	111
D	GND(14 Ga.)
E	19

CAVITY CIRCUIT	
A	24
B	112
C	111
D	GND(14 Ga.)
E	19

To Firewall Harness
Male Packard Terms*

Packard Conn. Typ. 2 Plcs.
Conn. Assy. P/N: 12084891
Terminal P/N: 12077412
Seal P/N: 15300023

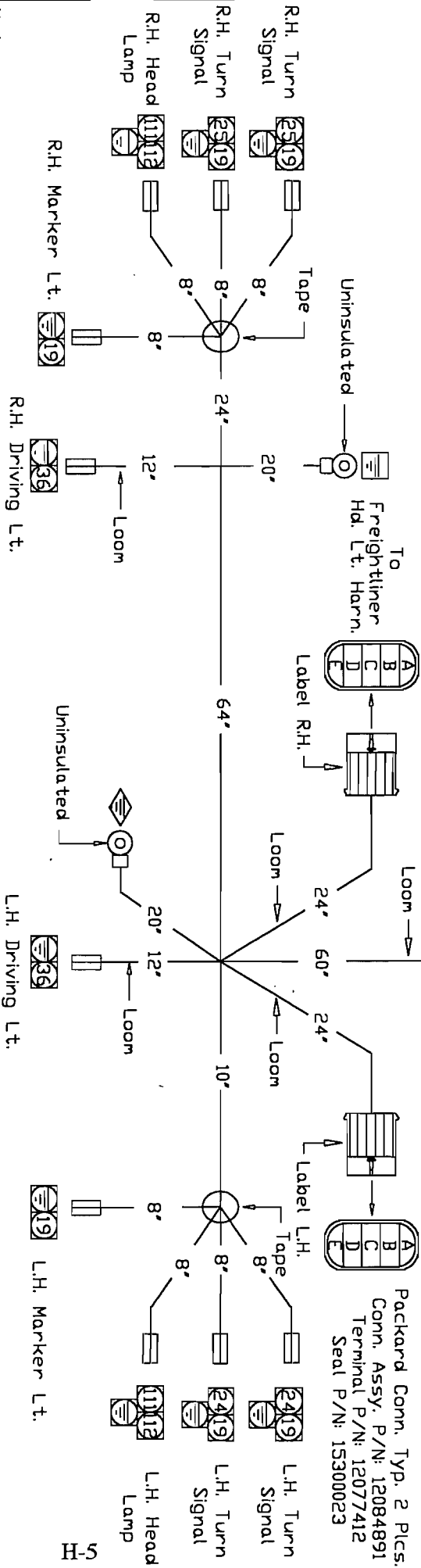

- Note:
1. All wire to be type GXL, 125C, UL/CSA listed.
 2. All ground wire (=) to be black.
 3. Loom entire harness.
 4. Tape all wire sets.

No.	Ga	Color	Length(In.)	Function
19	14	Brown	264	Park Lamps
24	14	Lt. Blue	113	Left Turn Lamp
25	14	Dk. Blue	192	Right Turn Lamp
36	14	Red/blk.	146	Driving Lts.
111	14	Lt. Green	192	Hd. Lts.(HI Beam)
112	14	Tan	158	Hd. Lt.(LO Beam RH)

Terminals	
□	Butt Conn., Heat Shrink
◇	Bullet .180 Male
◇	Bullet .180 Female
□	Butt Connector
○	Ring .250 I.D.
□	Spade .250 Female
□	Spade .250 Male
□	Coax Connector

ITEM	PART NUMBER	DESCRIPTION	QTY	UM
Airstream TITLE: <i>Harness, Headlight</i> SCALE: 1-1 DATE: 01/15/99 DRAWING NUMBER: 511472 REV.: B				
TOLERANCES		DRAWN BY R.L.A.		
± .1"		APPROVED BY		
NEXT ASSY		PRODUCT LINE XL Diesel 390 L/Y Mh.		

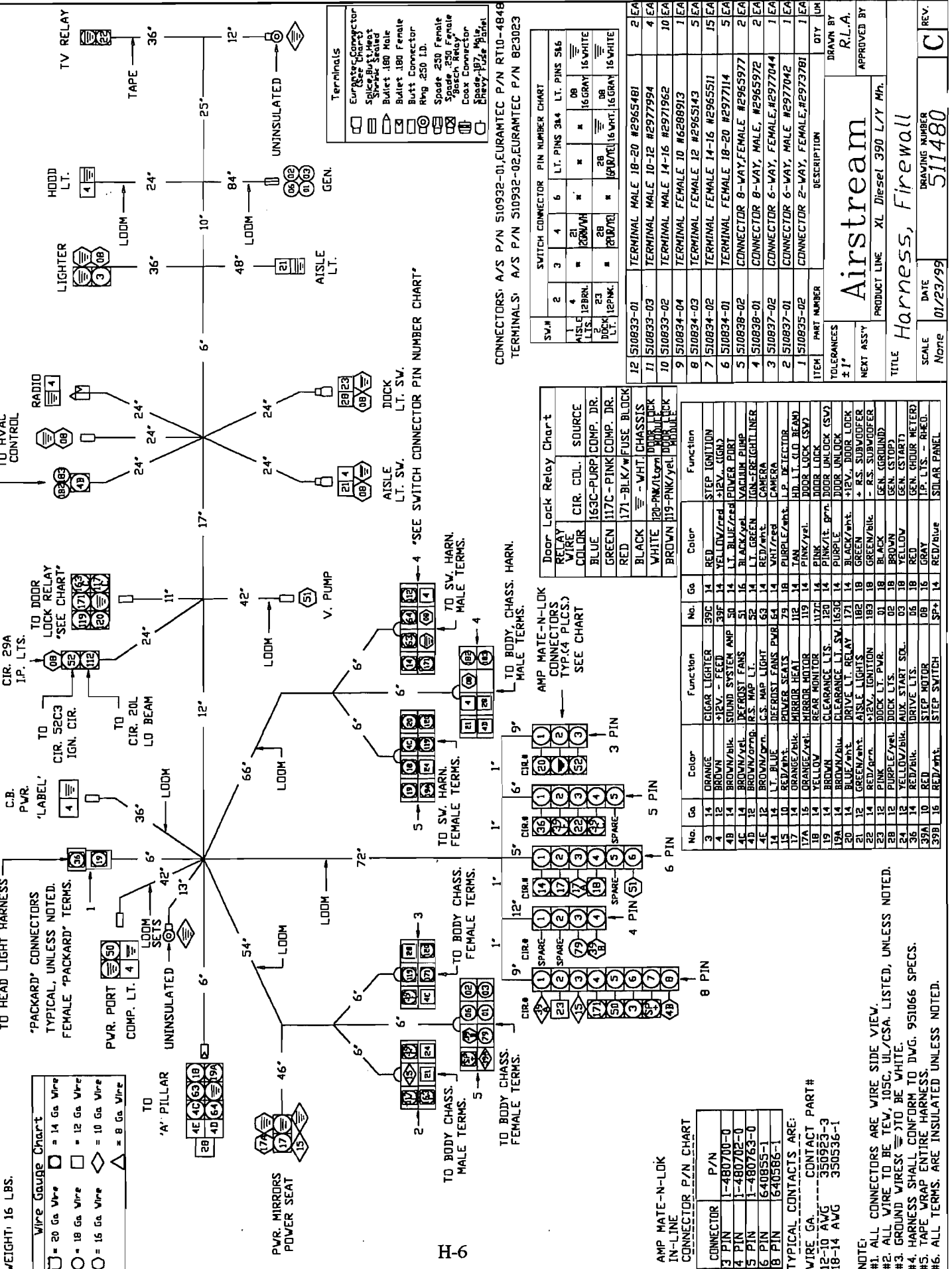

Wire Gauge Chart

□	= 20 Ga. Wire
○	= 18 Ga. Wire
◇	= 16 Ga. Wire
△	= 14 Ga. Wire
◇	= 12 Ga. Wire
△	= 10 Ga. Wire
△	= 8 Ga. Wire

Terminals

□	European Connector
□	Splice Butt Heat Shrink Seal
□	Bullet .180 Male
□	Bullet .250 Female
□	Ring .250 I.D.
□	Spade .250 Female
□	Spade .250 Male
□	Coax Connector
□	Energy 105# 2.5mm

CONNECTORS: A/S P/N 510932-01, EURAMTEC P/N RT10-4848
TERMINALS: A/S P/N 510932-02, EURAMTEC P/N 823023

SWITCH CONNECTOR PIN NUMBER CHART

S.W.#	2	3	4	5	6	LT. PINS 3&4	LT. PINS 5&6
1	ASISLE	12BN	21	28	28	16 GRAY	16 WHITE
2	DOCK	12PNK	28	28	28	16 WHT.	16 GRAY
3	DOCK	12PNK	28	28	28	16 WHT.	16 GRAY

12	510833-01	TERMINAL MALE 18-20 #2965481	2	EA
11	510833-03	TERMINAL MALE 10-12 #2977994	4	EA
10	510833-02	TERMINAL MALE 10 #6288913	10	EA
9	510834-04	TERMINAL FEMALE 12 #2965511	1	EA
8	510834-02	TERMINAL FEMALE 12 #2965513	5	EA
7	510834-03	TERMINAL FEMALE 18-20 #2977114	15	EA
6	510834-01	TERMINAL FEMALE 18-20 #2977114	5	EA
5	510838-01	CONNECTOR 8-WAY, FEMALE #2965977	2	EA
4	510838-02	CONNECTOR 8-WAY, MALE #2965972	2	EA
3	510837-02	CONNECTOR 6-WAY, FEMALE #2977044	1	EA
2	510837-01	CONNECTOR 6-WAY, MALE #2977042	1	EA
1	510835-02	CONNECTOR 2-WAY, FEMALE #2973781	1	EA

TOLERANCES ±1"

NEXT ASSY

TITLE: **Airstream**
Product Line: **Harness, Firewall**

SCALE: None DATE: 01/23/99 DRAWING NUMBER: 511480

REV. C

APPROVED BY: R.L.A.
DRAWN BY: R.L.A.

Door Lock Relay Chart

RELAY WIRE COLOR	CIR. COL.	SOURCE
BLUE	163C-PURP	COMP. DR.
GREEN	117C-PINK	COMP. DR.
RED	171-BLK/W	FUSE BLOCK
BLACK	-	WHT. CHASSIS
WHITE	120-PNK/Yel	DOOR LOCK
BROWN	119-PNK/Yel	DOOR LOCK

No.	Color	Function	No.	Color	Function
3	ORANGE	CIGAR LIGHTER	39C	RED	STEP IGNITION
4	BROWN	+REV. - FEED	39E	YELLOW/RED	+REV. (IGN)
4B	BROWN/BLK	SOUND SYSTEM AMP	50	LT. BLUE/RED	POWER PORT
4C	BROWN/BLK	DEFROST FANS	51	BLACK/YEL	VACUUM PUMP
4D	BROWN/OPN.	R.S. MAP LT.	52	LT. GREEN	IGN-FREIGHTLINER
4E	BROWN/OPN.	G.S. MAP LIGHT	63	RED/WHT.	CAMERA
14	LT. BLUE	DEFROST FANS PWR	64	WHT./RED	CAMERA
15	RED/WHT.	POWER SEATS	75	PURPLE/WHT.	L.P. DETECTOR
17	ORANGE/PNK	MIRROR HEAT	112	TAN	HD. LT. LO BEAM
17A	ORANGE/YEL	REAR MONITOR	119	PINK/YEL	DOOR LOCK (SV2)
18	YELLOW	CLEARANCE L.T.S.	120	PINK/YEL	DOOR UNLOCK (SV2)
19A	BROWN/BLK	DRIVE L.T. RELAY	171	BLACK/WHT.	+REV. DOOR LOCK
20	LT. BLUE/WHT.	DOOR L.T. RELAY	182	GREEN	+R.S. SUBWOOFER
21	GREEN/WHT.	DOOR L.T. RELAY	183	GREEN/BLK	+R.S. SUBWOOFER
22	RED/OPN.	DOCK LT. PWR.	01	BLACK	GEN. GROUND
23	PINK	DOCK L.T. PWR.	02	BROWN	GEN. GROUND
24	PURPLE/YEL	AUX. START SOL.	03	YELLOW	GEN. GROUND
28	YELLOW/BLK	DRIVE L.T.S.	06	RED	GEN. CHOUR (METER)
36	RED	STEP MOTOR	08	GRAY	L.P. L.T.S. - RELO.
39A	RED	STEP MOTOR	08	GRAY	L.P. L.T.S. - RELO.
39B	RED/WHT.	STEP SWITCH	SP*	RED/BLU*	STILLAR PANEL

AMP MATE-N-LOK IN-LINE CONNECTOR P/N CHART

CONNECTOR	P/N
3 PIN	1-480700-0
4 PIN	1-480702-0
5 PIN	1-480763-0
6 PIN	640855-1
8 PIN	640586-1

TYPICAL CONTACTS ARE:
WIRE GA. --- CONTACT PART #
12-10 AWG 350923-3
18-14 AWG 350536-1

NOTE:
#1. ALL CONNECTORS ARE WIRE SIDE VIEW.
#2. ALL WIRE TO BE TEW, 105C, UL/CSA. LISTED, UNLESS NOTED.
#3. GROUND WIRES TO BE WHITE.
#4. HARNESS SHALL CONFORM TO DWG. 951066 SPECS.
#5. TAPE WRAP ENTIRE HARNESS.
#6. ALL TERMS. ARE INSULATED UNLESS NOTED.

511282-01

Wire Gauge Chart

□ = 20 Ga Wire	○ = 14 Ga Wire
○ = 18 Ga Wire	□ = 12 Ga Wire
○ = 16 Ga Wire	◇ = 10 Ga Wire
	△ = 8 Ga Wire

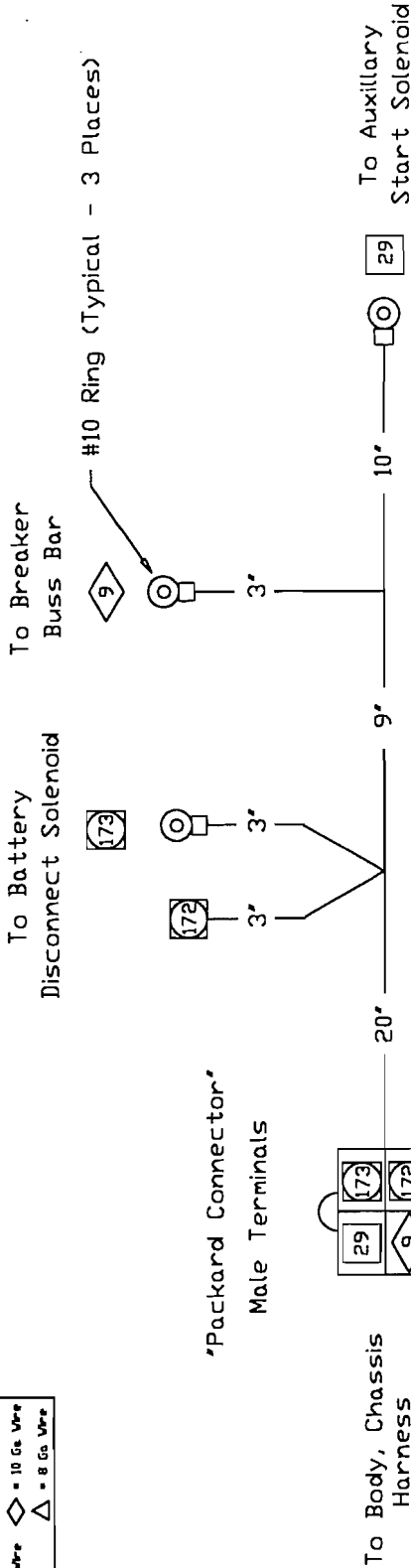

LET	DATE	E.C.N.	REVISION RECORD	BY
A	11/95	4526C	Production Release	RA
	12/98	4736	Rev. For Freightliner Sys. 3 Chass.	RA

H-7

4	510833-03	TERMINAL MALE 10-12	#2977994	1 EA
3	510833-02	TERMINAL MALE 14-16	#2971962	3 EA
2	*			* *
1	510836-01	CONNECTOR 4-WAY, MALE,	#6294544	1 EA
ITEM	PART NUMBER	DESCRIPTION		
TOLERANCES ± 1*				
NEXT ASSY				
DRAWN BY R.L.A.				
APPROVED BY				
PRODUCT LINE				
<h1>Airstream</h1>				
TITLE Harness, Chass. Elec. Components				
SCALE 1=1	DATE 11/10/95	DRAWING NUMBER 511282-01	REV. B	REV. A

No.	Ga	Color	Function
29	12	Yellow/blk.	Aux. Start Sol.
172	14	Orange	+12V. (Aux Batt.)
173	14	Orange/blk.	Aux. Batt. Sol.
9	10	Green	+12V. (Inverter)
*	*	*	*
*	*	*	*
*	*	*	*
*	*	*	*
*	*	*	*
*	*	*	*

Terminals

□	Bullet .180 Male
○	Bullet .180 Female
□	Butt Connector
○	Ring .250 ID.
○	Spade .250 Female
○	Spade .250 Male
□	Cox Connector

- Note:
- All connectors are wire side view.
 - All wire to be GXL 125C.
 - Tape wrap entire harness.
 - All terms. are insulated.

LET	DATE	E.C.N.	REVISION RECORD	BY
	4/79	4751	Production Release	RA

WEIGHT: 28 LBS.

FRONT →

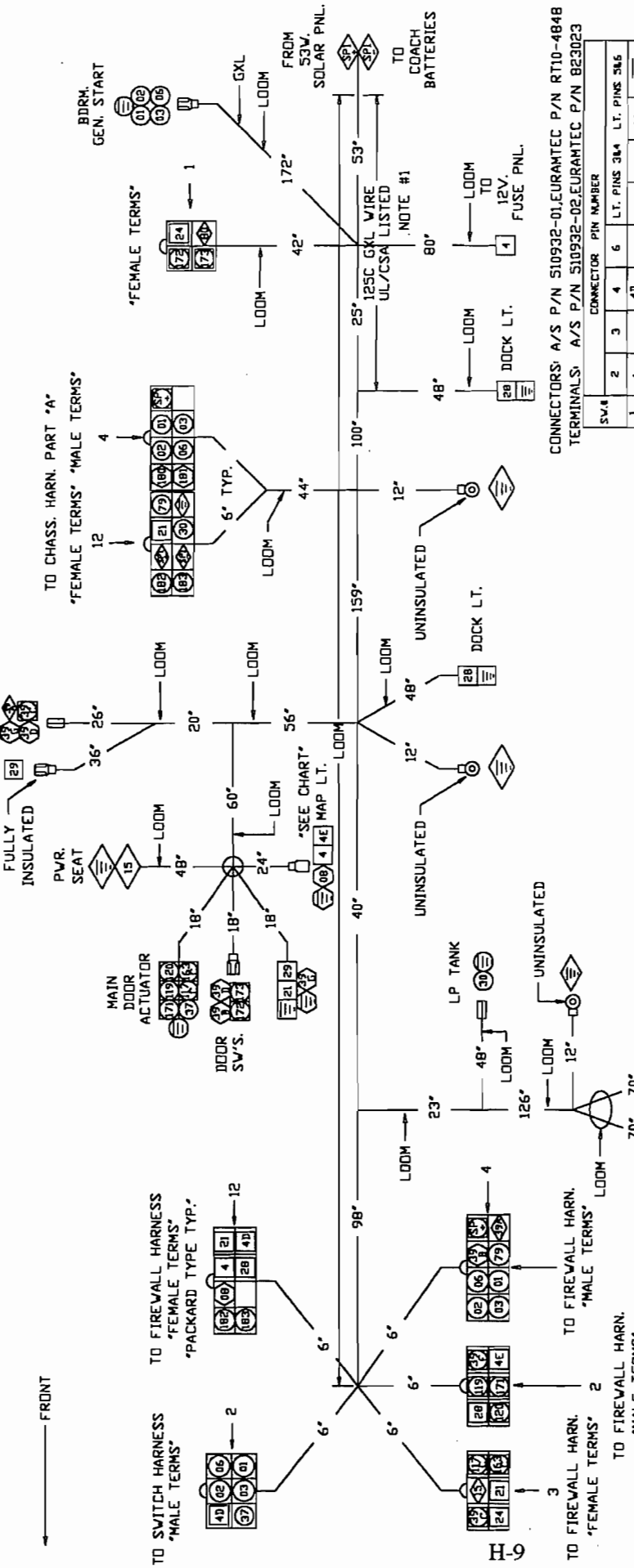

No.	Color	Custom Length	Function
01	BLK	18"	GEN. GROUND
02	BRN	18"	GEN. START
03	YEL	18"	GEN. CHAUFFEUR
04	RED	18"	STEP
12	BRN	18"	R.S. MAP LIGHT
18	BRN	18"	P.W. MAP LIGHT
19	BRN	18"	GEN. START SW.
21	GRN	18"	MAP LIGHT SW.
24	YEL	18"	DOCK LIGHT
28	PUR	18"	DOCK LIGHT
29	BRN	18"	DOCK LIGHT
31	BRN	18"	DOCK LIGHT
32	BRN	18"	DOCK LIGHT
33	BRN	18"	DOCK LIGHT
34	BRN	18"	DOCK LIGHT
35	BRN	18"	DOCK LIGHT
36	BRN	18"	DOCK LIGHT
37	BRN	18"	DOCK LIGHT
38	BRN	18"	DOCK LIGHT
39	BRN	18"	DOCK LIGHT
40	BRN	18"	DOCK LIGHT
41	BRN	18"	DOCK LIGHT
42	BRN	18"	DOCK LIGHT
43	BRN	18"	DOCK LIGHT
44	BRN	18"	DOCK LIGHT
45	BRN	18"	DOCK LIGHT
46	BRN	18"	DOCK LIGHT
47	BRN	18"	DOCK LIGHT
48	BRN	18"	DOCK LIGHT
49	BRN	18"	DOCK LIGHT
50	BRN	18"	DOCK LIGHT
51	BRN	18"	DOCK LIGHT
52	BRN	18"	DOCK LIGHT
53	BRN	18"	DOCK LIGHT
54	BRN	18"	DOCK LIGHT
55	BRN	18"	DOCK LIGHT
56	BRN	18"	DOCK LIGHT
57	BRN	18"	DOCK LIGHT
58	BRN	18"	DOCK LIGHT
59	BRN	18"	DOCK LIGHT
60	BRN	18"	DOCK LIGHT

RELAY	PIN 30	PIN 31	PIN 32	PIN 33	PIN 34	PIN 35	PIN 36	PIN 37	PIN 38	PIN 39	PIN 40	PIN 41	DESCRIPTION	QTY	UN
SLIDE-OUT	10-BLK.	80	14-White	14-YEL/RD	37	80A			10-BLK/YEL						
12	510838-02	CONNECTOR	8-WAY	FEMALE	#2965977										
11	510833-03	TERMINAL	MALE 10-12	#2977994											
10	510833-02	TERMINAL	MALE 14-16	#2971962											
9	510833-01	TERMINAL	MALE 18-20	#2965481											
8	510834-04	TERMINAL	FEMALE 10	#6288913											
7	510834-03	TERMINAL	FEMALE 12	#2965143											
6	510834-02	TERMINAL	FEMALE 14-16	#2965511											
5	510834-01	TERMINAL	FEMALE 18-20	#2977114											
4	510838-01	CONNECTOR	8-WAY	MALE	#2965972										
3	510837-02	CONNECTOR	6-WAY	FEMALE	#2977044										
2	510837-01	CONNECTOR	6-WAY	MALE	#2977042										
1	510836-02	CONNECTOR	4-WAY	FEMALE	#2977048										

Wire Gauge Chart

- 20 Ga Wire
- 18 Ga Wire
- 16 Ga Wire
- 14 Ga Wire
- 12 Ga Wire
- 10 Ga Wire
- 8 Ga Wire

Terminals

- Spade Connector
- Spade, Butt, Heat
- Spade, Ring
- Bullet, 180 Male
- Bullet, 180 Female
- Butt Connector
- Ring, 250 U.D.
- Spade, 250 Female
- Spade, 250 Male
- Spade, 250 Ring
- Coat Connector

NOTE:
 #1. ALL CONNECTORS ARE WIRE SIDE VIEW.
 #2. ALL WIRE TO BE TEV, 105C, UL/C.S.A. LISTED- UNLESS NOTED.
 #3. GROUND WIRES TO BE WHITE.
 #4. ALL TERMS. ARE INSULATED UNLESS NOTED.

Airstream
 PRODUCT LINE: XL Diesel 390 LY Mh.
 HARNESS, Body, Chass., Part "B"
 DRAWING NUMBER: 511476
 DATE: 01/19/99
 SCALE: None
 TITLE: Harness, Body, Chass., Part "B"
 DRAWN BY: R.L.A.
 APPROVED BY: C

CONNECTORS: A/S P/N 510932-01, EURAMTEC P/N RT10-4848
 TERMINALS: A/S P/N 510932-02, EURAMTEC P/N B23023

SV#	2	3	4	6	LT. PINS 384	LT. PINS 585
MAP	40	40	280A/OK			
L.T.	12BRN				DB	16WHITE

Terminals	
	Bullet .180 Male
	Bullet .180 Female
	Bullet .156 Female
	Bullet .156 Male
	Butt Connector
	Ring Connector
	Spade .250 Female
	Spade .250 Male
	Coax Connector
	Spade .110 Female

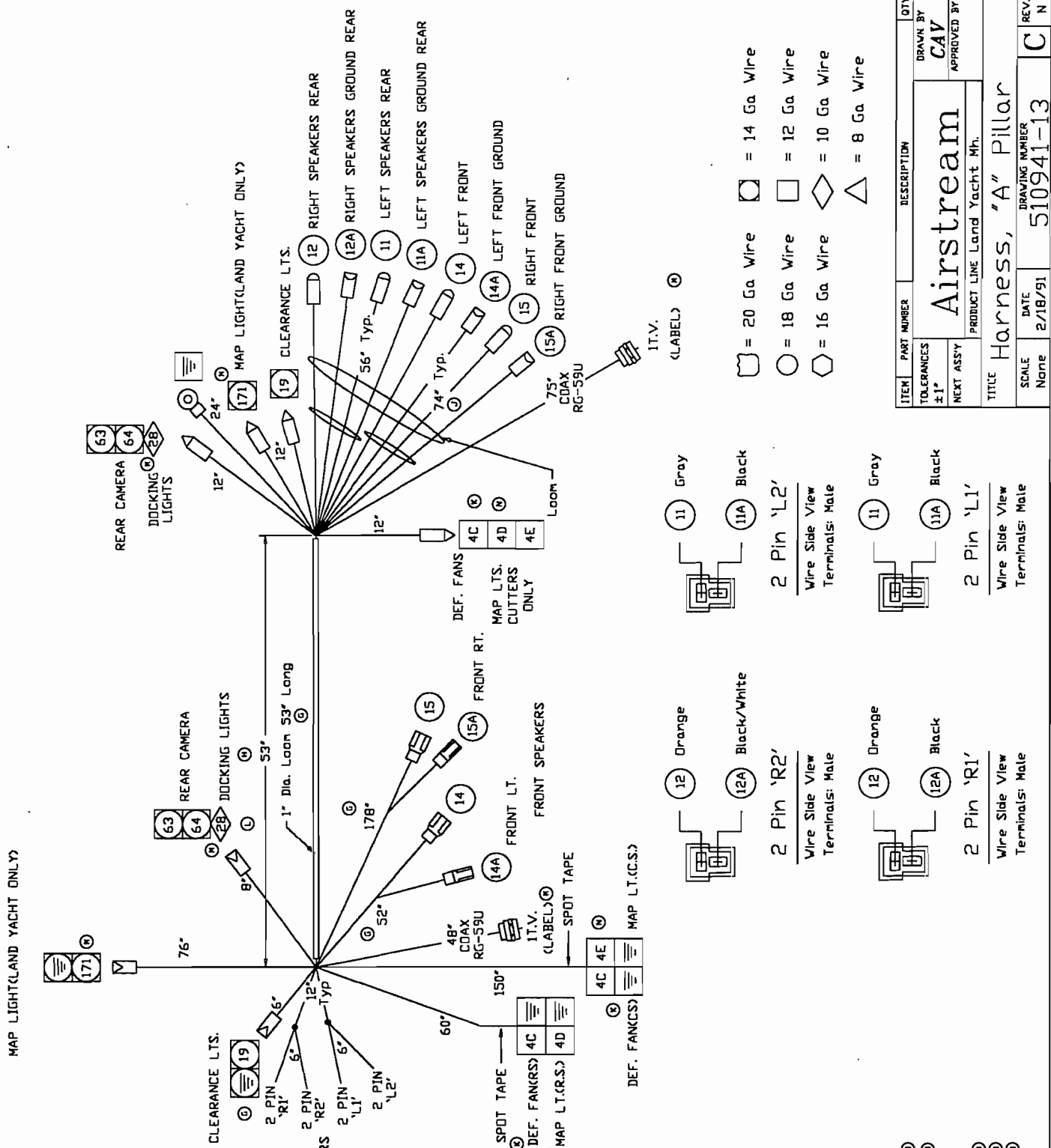

No.	Ga.	Color
3	12	Orange
11	18	Gray
11A	18	Black
12	18	Orange
12A	18	Black/White
14	18	Blue
14A	18	Black
15	18	Red
15A	18	Black/White
19	14	Brown
28	10	Purple/Yel.
171	14	Black/Wht.
63	14	Red/Wht.
64	14	Wht/Red
4C	12	Brown/yel.
4D	12	Brown/orng.
4E	12	Brown/grn.

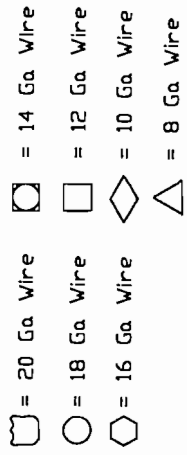
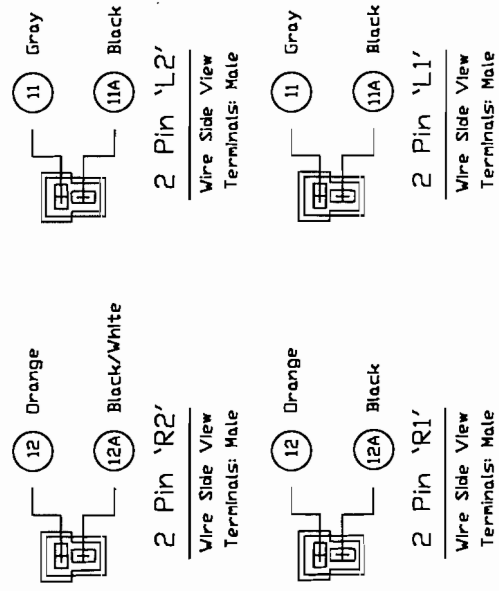

ITEM	PART NUMBER	DESCRIPTION	QTY
TOLERANCES ± 1"			
DRAWN BY CAV			
APPROVED BY			
TITLE Harness, "A" Pillar			
PRODUCT LINE Land Yacht Mh.			
SCALE None	DATE 2/18/91	DRAWING NUMBER 510941-13	REV. C

- | Terminals | |
|-----------|--------------------|
| | Bullet .180 Male |
| | Bullet .180 Female |
| | Butt Connector |
| | Ring .250 I.D. |
| | Spade .250 Female |
| | Spade .250 Male |
| | Coax Connector |

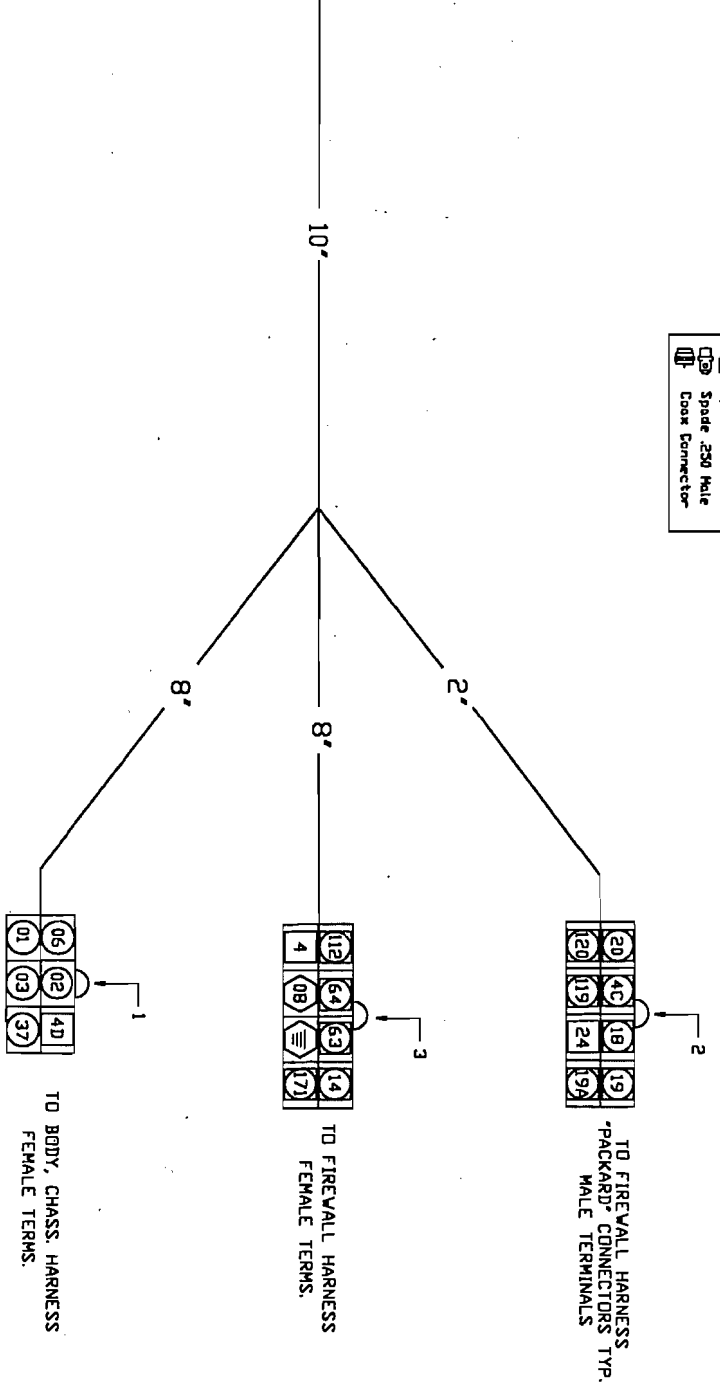
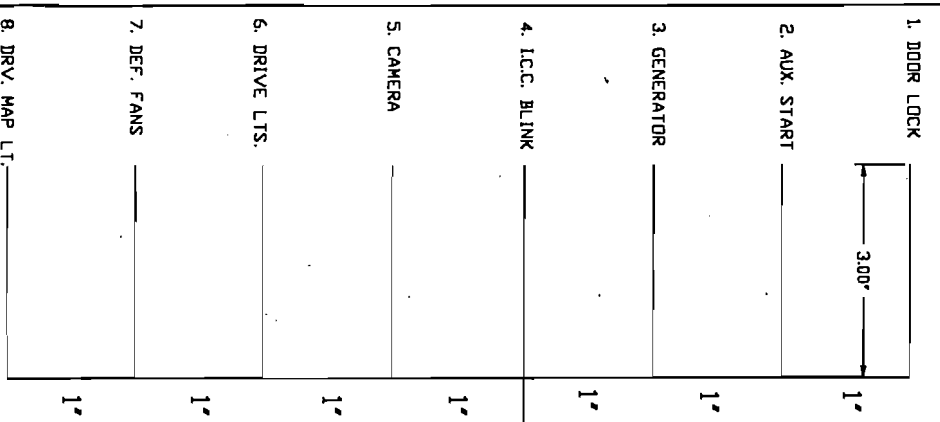

TERMINALS: A/S P/N S10932-02, EURAMTEC P/N B23023
CONNECTORS: A/S P/N S10932-01, EURAMTEC P/N RT10-4848

SV#	1	2	3	4	5	6	7	8	9	10	11	12	13	14	15	16	17	18	19	20	21	22	23	24	25	26	27	28	29	30	31	32	33	34	35	36	37
DOOR LOCK	171	112	53	29	64	53	41	19A	19A	19A	19A	19A	19A	19A	19A	19A	19A	19A	19A	19A	19A	19A	19A	19A	19A	19A	19A	19A	19A	19A	19A	19A	19A	19A	19A		

- DOOR LOCK
 - AUX. START
 - GENERATOR
 - I.C.C. BLINK
 - CAMERA
 - DRIVE LITS.
 - DEF. FANS
 - DRV. MAP LT.
- NOTE:
1. ALL CONNECTORS ARE WIRE SIDE VIEW.
2. TAPE WRAP HARNESS.
3. GROUND WIRES TO BE WHITE.
4. ALL WIRE TO BE TEV, 105C, UL/CSA.

SV#	1	2	3	4	5	6	7	8	9	10	11	12	13	14	15	16	17	18	19	20	21	22	23	24	25	26	27	28	29	30	31	32	33	34	35	36	37
DOOR LOCK	171	112	53	29	64	53	41	19A	19A	19A	19A	19A	19A	19A	19A	19A	19A	19A	19A	19A	19A	19A	19A	19A	19A	19A	19A	19A	19A	19A	19A	19A	19A	19A	19A	19A	

ITEM	PART NUMBER	DESCRIPTION	QTY	UOM
1	S10937-02	CONNECTOR 6-WAY, FEMALE #2972044	1	EA
2	S10938-01	CONNECTOR 8-WAY, FEMALE #2965972	1	EA
3	S10939-02	CONNECTOR 8-WAY, FEMALE #2965977	1	EA
4	S10934-01	TERMINAL FEMALE 18-20 #2972114	5	EA
5	S10934-02	TERMINAL FEMALE 14-16 #2965511	7	EA
6	S10934-03	TERMINAL FEMALE 12 #2965143	1	EA
7	S10933-02	TERMINAL MALE 10-12 #2977994	1	EA
8	S10933-03	TERMINAL MALE 10-12 #2977994	1	EA

Airstream
DRAWING NUMBER 511481
REV. C

510990

LET DATE	E.C.N.	REVISION RECORD	BY
10/91	4315D	Production Release	GS

- = 20 Ga Wire
- = 18 Ga Wire
- = 16 Ga Wire
- = 14 Ga Wire
- = 12 Ga Wire
- = 10 Ga Wire
- = 8 Ga Wire

TO 'A' OR
TAIL LIGHT

CLEARANCE LTS.

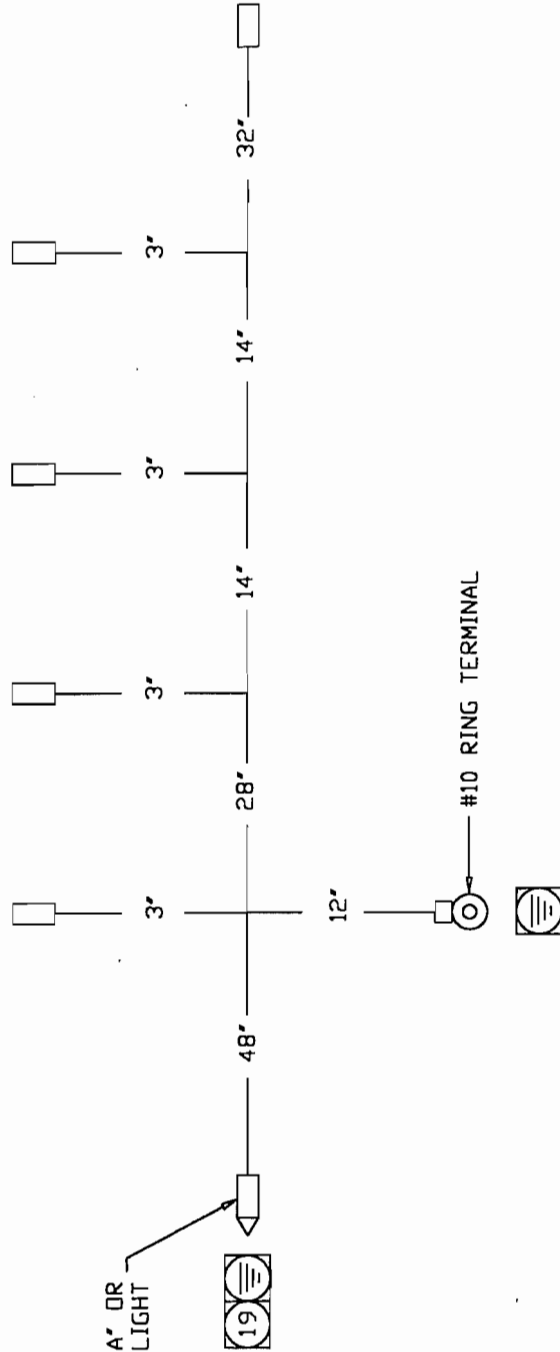
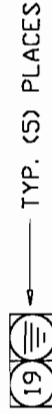

Terminals	
	Bullet .180 Male
	Bullet .180 Female
	Butt Connector
	Ring .250 I.D.
	Spade .250 Female
	Spade .250 Male
	Coax Connector

No.	Ga.	Color	Function
19	14	BROWN	CLEARANCE LTS.
	14	White	GROUND

NOTE:
1. ALL WIRE TO BE TEW 105C, UL/CSA.
2. GROUND WIRES TO BE WHITE.

ITEM	PART NUMBER	DESCRIPTION	QTY	UM
TOLERANCES				
± 1'				
NEXT ASS'Y				
FIRST USAGE:				
<h1>Airstream</h1>				
DRAWN BY G.C.S.				
APPROVED BY				

TITLE		Harness, Light, Clearance	
SCALE	DATE	DRAWING NUMBER	REV.
1=1	8/27/91	510990	B

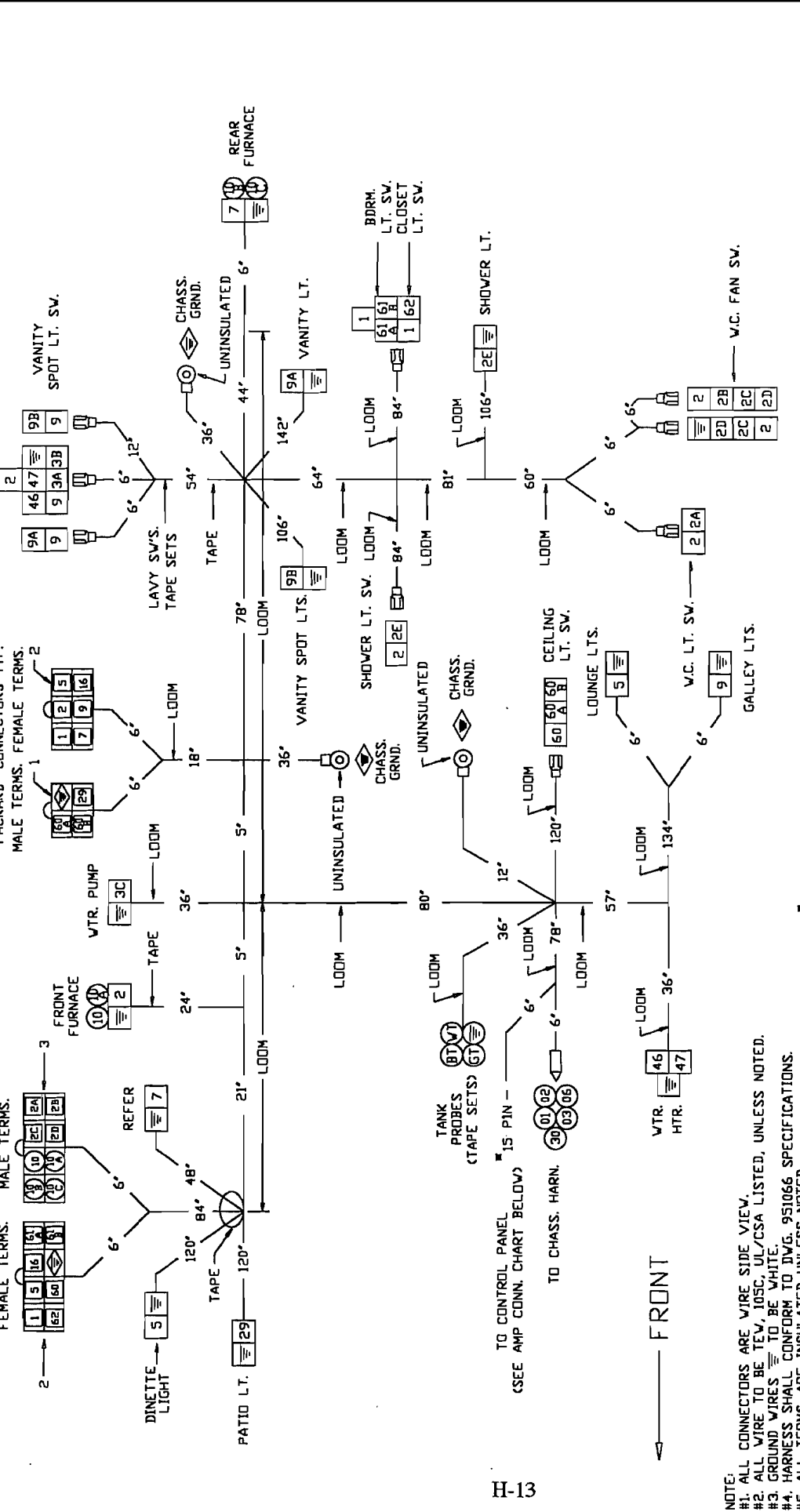

No.	Ga.	Color	Function	No.	Ga.	Color	Function
1	12	PURPLE	12V FEED	46	12	BROWN	WATER HEATER
2	12	YELLOW	12V FEED	47	12	BLUE	WATER HEATER
2A	12	YELLOW/RED	BATH LIGHT	60	12	BLACK/WHI.	FRNT. CEILING L.T.S.
2B	12	BLACK/RED	+12V. BATH FAN	60	12	BLACK/WHI.	FRNT. CEILING L.T.S.
2C	12	GRAY/RED	BATH FAN SV.	60A	12	BLACK/YEL.	FRNT. CEILING L.T. SV.
2D	12	BLUE/RED	BATH FAN SV.	60B	12	BLACK/YEL.	FRNT. CEILING L.T. SV.
2E	12	BLUE/WHI.	SHOWER LT.	61A	12	PURPLE/WHI.	BDRM. CEILING L.T. SV.
3A	12	ORANGE	WATER PUMP/SV.	61B	12	PURPLE/WHI.	BDRM. CEILING L.T. SV.
3B	12	ORANGE/WHI.	WATER PUMP	62	12	PURPLE/WHI.	BDRM. CLOSET L.T. SV.
3C	12	BLUE	12V FEED	81	12	BROWN	BULK TANK-PROBE
4	12	ORANGE	12V FEED	81	12	RED	FRESH WTR-PROBE
5	12	GREEN	12V FEED	81	12	BLACK	GEN. GROUND
6	12	GREEN/YEL.	VANITY LT.	82	12	BROWN	GEN. START
7	12	GREEN/YEL.	VANITY SPOT L.T.S.	82	12	YELLOW	GEN. HOUR METER
8	12	BLUE	THERM. FRONT FURN2	86	12	RED	
9A	12	BLUE/WHI.	THERM. FRONT FURN3				
9B	12	RED	THERM. REAR FURN2				
9C	12	RED	THERM. REAR FURN3				
10A	12	RED/WHI.	THERM. REAR FURN2				
10B	12	RED	THERM. REAR FURN3				
10C	12	RED/WHI.	THERM. REAR FURN2				
10D	12	RED	THERM. REAR FURN3				
16	12	BLACK	+12V. FEED				
29	12	BROWN/WHI.	PATIO LT.				
30	18	L.T. BLUE/WHI.	1/2" GAUGE				

ITEM	PART NUMBER	DESCRIPTION	QTY	UH
7	510834-04	TERMINAL FEMALE 10 #6288913	1	EA
6	510834-03	TERMINAL FEMALE 12. #2965143	13	EA
5	510833-03	TERMINAL MALE 10-12. #2977994	8	EA
4	510833-01	TERMINAL MALE 18-20. #2965481	4	EA
3	510838-01	CONNECTOR 8-WAY, MALE. #2965992	1	EA
2	510838-02	CONNECTOR 8-WAY, FEMALE. #2965997	1	EA
1	510836-01	CONNECTOR 4-WAY, MALE. #6294544	1	EA

TO GRANCES	± 1"	DRIVEN BY
		R.L.A.

TITLE	DATE	DRAWING NUMBER	REV.
Harness, Body, Int. Part 'A'	01/15/99	511479	C

WIRE GA. CHART
 □ = 20 GA. WIRE □ = 14 GA. WIRE
 ○ = 18 GA. WIRE □ = 12 GA. WIRE
 ○ = 16 GA. WIRE □ = 10 GA. WIRE
 ○ = 15 GA. WIRE △ = 8 GA. WIRE

Terminals
 ⊙ Bullet .180 Male
 ⊙ Bullet .180 Female
 ⊙ Butt Connector
 ⊙ Ring .250 I.D.
 ⊙ Spade .250 Female
 ⊙ Spade .250 Male
 ⊙ Coax Connector

HOUSING P/N 1-480711-0
 SOCKET P/N 350537-1 (20-14 GA. WIRE)
 SOCKET P/N 350570-1 (18-24 GA. WIRE)
 SOCKET P/N 350923-3 (12-10 GA. WIRE)

15 PIN AMP CONN.

NOTE:
 #1. ALL CONNECTORS ARE WIRE SIDE VIEW.
 #2. ALL WIRE TO BE TEW, 10SC, UL/CSA LISTED, UNLESS NOTED.
 #3. GROUND WIRES TO BE WHITE.
 #4. HARNESS SHALL CONFORM TO DWG. 951066 SPECIFICATIONS.
 #5. ALL TERMS ARE INSULATED UNLESS NOTED.

LET DATE	E.C.N.	REVISION RECORD	BY
4/99	4751	Production Release	RA

511478
WEIGHT: 17 LBS.

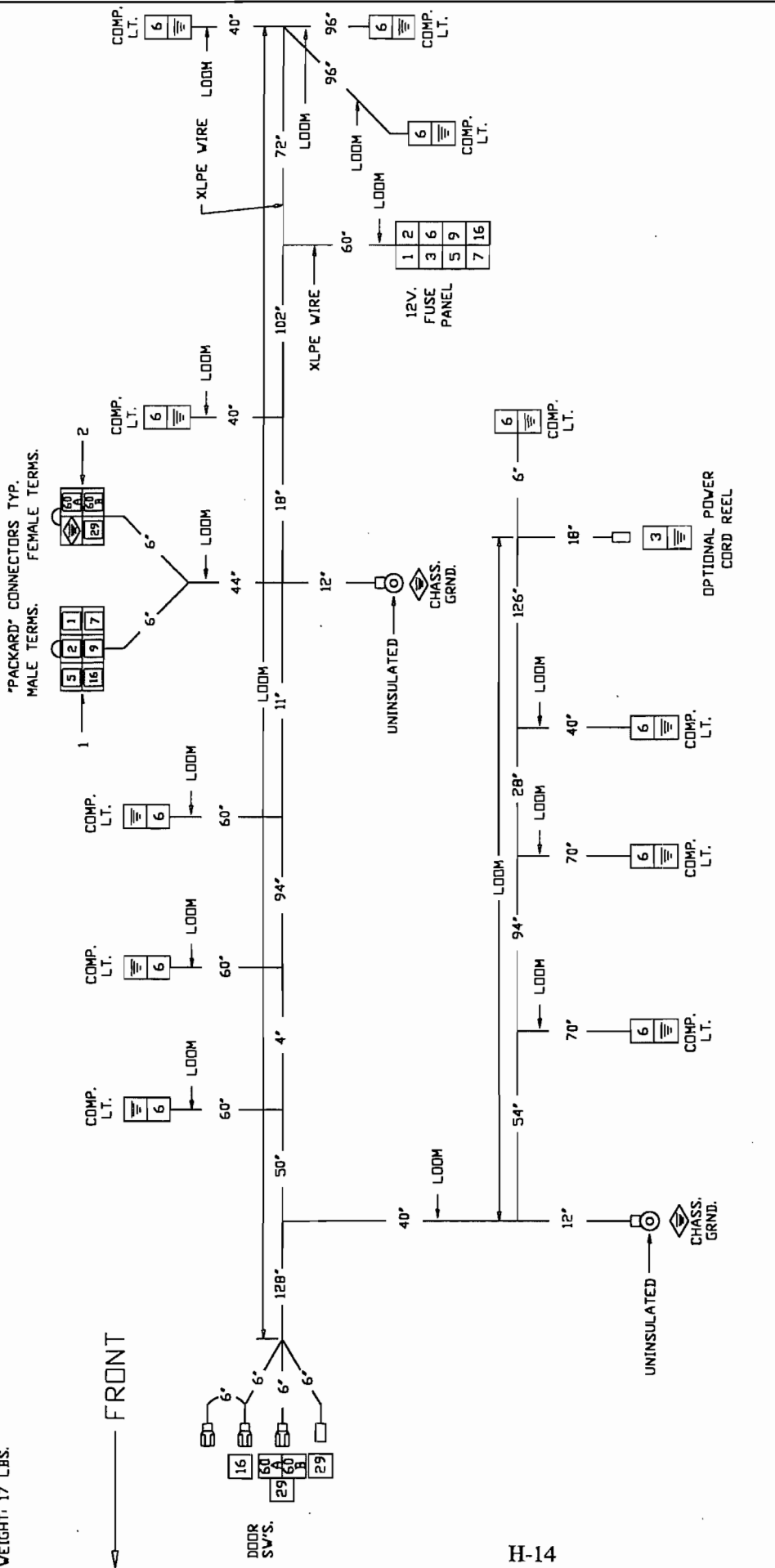

NOTE:
 #1. ALL CONNECTORS ARE WIRE SIDE VIEW.
 #2. ALL WIRE TO BE TEV, 105C, UL/CSA LISTED, UNLESS NOTED.
 #3. GROUND WIRES TO BE WHITE.
 #4. HARNESS SHALL CONFORM TO DWG. 951066 SPECIFICATIONS.
 #5. ALL TERMS. ARE INSULATED UNLESS NOTED.

5	510834-04	TERMINAL FEMALE 10 #6288913	1	EA
4	510834-03	TERMINAL FEMALE 12 #2965143	3	EA
3	510833-03	TERMINAL MALE 10-12 #2977994	6	EA
2	510837-01	CONNECTOR 6-WAY, MALE, #2977042	1	EA
1	510836-02	CONNECTOR 4-WAY, FEMALE, #2977048	1	EA

TOLERANCES		DESCRIPTION	QTY	UM
±.1"				
NEXT ASSY		DRAWN BY R.L.A.		
		APPROVED BY		
TITLE Harness, Body, Int. Part "B"				
PRODUCT LINE XL Diesel 390 L/Y Mh.				
SCALE	DATE	DRAWING NUMBER		
None	01/20/99	511478		
REV.				C

Terminals	
	Bullet .180 Male
	Butt Connector
	Ring .250 I.D.
	Spade .250 Female
	Coax Connector

WIRE GA. CHART			
	= 20 Ga Wire		= 14 Ga Wire
	= 18 Ga Wire		= 12 Ga Wire
	= 16 Ga Wire		= 10 Ga Wire
	= 8 Ga Wire		

No.	Ga	Color	Function
1	12	PURPLE	12V. FEED
2	12	YELLOW	12V. FEED
3	12	PINK	12V. FEED
5	12	BLUE	12V. FEED
6	12	RED	12V. FEED
7	12	ORANGE	12V. FEED
9	12	GREEN	12V. FEED
16	12	BLACK	12V. FEED
29	12	BROWN/whit.	PATIO STEP LIGHTS
60A	12	BLACK/vel.	FRONT CEILING L.T. SW.
60B	12	BLACK/vel.	FRONT CEILING L.T. SW.

H-14

- = 20 Ga. Wire
- = 18 Ga. Wire
- ◇ = 16 Ga. Wire
- = 14 Ga. Wire
- = 12 Ga. Wire
- ◇ = 10 Ga. Wire
- △ = 8 Ga. Wire

WEIGHT: 17 LBS.

FRONT

R/S REAR

IDENTIFY (BY LABEL) ALL COAX ENDS

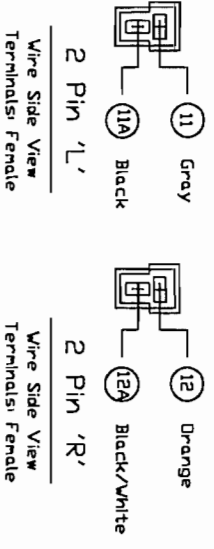
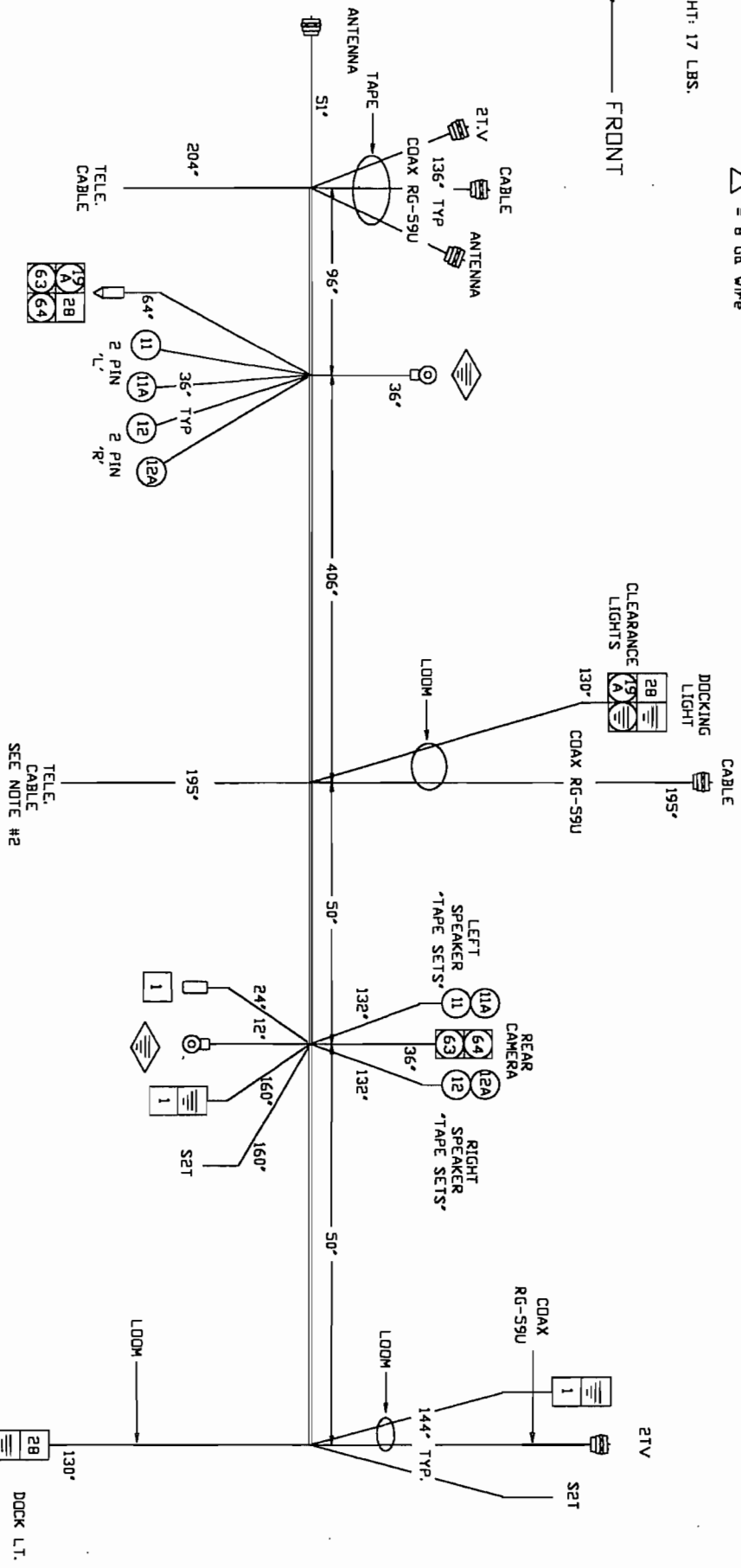

NOTE:
 #1. All wire to be TEW, 105C, UL/C.S.A. listed except as noted.
 #2. Telephone cable to be standard round, 22 ga., solid,
 (4) conductor with jacket for tele. jack consisting
 of red, green, yellow and black wires.

Terminal	Terminal
▶ Bullet .180 Male	▶ Bullet .180 Female
◻ Butt Connector	◻ Ring .250 I.D.
◻ Spade .250 Female	◻ Spade .250 Male
◻ Coax Connector	

No.	Ga.	Color
1	12	Purple
11	18	Gray
11A	18	Black
12	18	Orange
12A	18	Black/White
19A	14	Brown/Blue
28	12	Purple/Yel.
63	14	Red/Whit.
64	14	White/Red
10	10	White
18	18	Gray-Gray/Whit.

TITLE		Harness, Body, Upper	
SCALE	DATE	DRAWING NUMBER	REV.
1=1	01/15/98	511471	C
PART NUMBER		DESCRIPTION	
Airstream		DVTY UN	
DRAWN BY		APPROVED BY	
R.L.A.			
PRODUCT LINE		XL Diesel 390 LY Mk.	

511263-01

LET DATE	E.C.N.	REVISION RECORD	BY
7/95	4526A	Production Release	RA
8/98	4736	Rev. Chass/Tail Lt. Harn. Conn.	RA

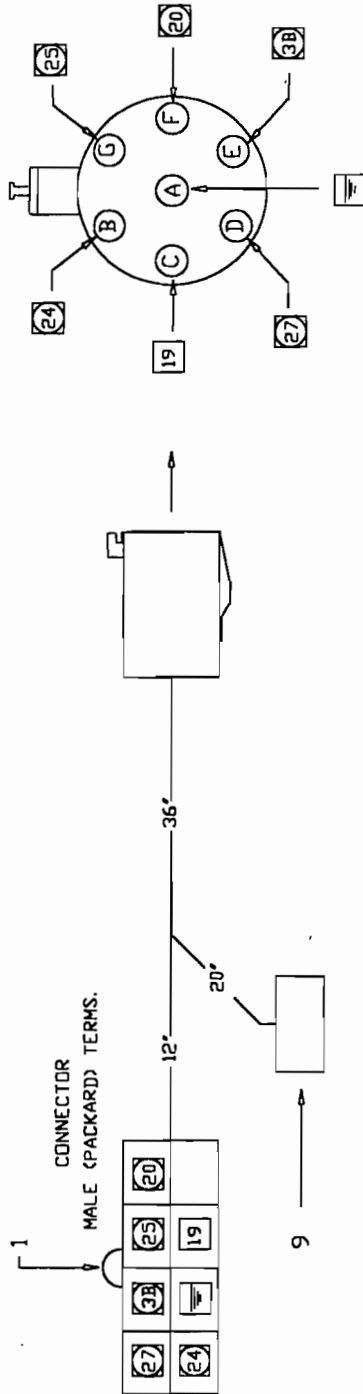

CHASS. CONN.
METRI PACK(MALE) - 280 SERIES
PACKARD-ELEC.
P/N: 12110753

MALE TERMS.
PACKARD-ELEC.
P/N: 12129497

TERMINAL SEAL
PACKARD-ELEC.
P/N: 12110752

SECONDARY LOCK
PACKARD-ELEC.
P/N: 12110754

A/S P/N: 510863-02
Vendor P/N: Wire Design, A30-403

H-17

Wire Gauge Chart

□	= 20 Ga Wire	□	= 14 Ga Wire
○	= 18 Ga Wire	□	= 12 Ga Wire
◇	= 16 Ga Wire	◇	= 10 Ga Wire
△	= 8 Ga Wire		

No.	Ga	Color	Function
3B	14	Red/Yellow	Center Brake Lt.
19	12	Brown	Clearance Lts.
20	14	Dk. Blue	Tail Lts.
24	14	Yellow	Left Turn Lt.
25	14	Dk. Green	Rt. Turn Lt.
27	14	Lt. Green	Back-Up Lts.
9	12	White	Ground
27	12	White	Ground
24	12	White	Ground
3B	12	White	Ground
25	12	White	Ground
20	12	White	Ground
19	12	White	Ground

Terminals

□	Heat-Shrink Butt
○	Bullet .180 Male
◇	Bullet .180 Female
□	Butt Connector
○	Ring .250 I.D.
◇	Spade .250 Female
□	Spade .250 Male
△	Coax Connector

- NOTE:
- ALL CONNECTORS ARE WIRE SIDE VIEW.
 - ALL WIRE TO BE GXL 125C, UNLESS NOTED.
 - LOOM ENTIRE HARNESS.
 - GROUND WIRES (≡) TO BE WHITE.

ITEM	PART NUMBER	DESCRIPTION	QTY	UM
11	510833-03	TERMINAL MALE 10-12 #2977994	2	EA
10	6000287-50	LOOM,CNVLT POLYE-SLIT 1\2 ID	5	FT
9	510863-02	PLUG B,LY MH TLITE HARN 510863	1	EA
8	511219-06	WIRE 14GA GXL WHITE	4	FT
7	511219-12	WIRE 14GA GXL 125C LT. GREEN	4	FT
6	511219-10	WIRE 14GA GXL 125C RED/YELLOW	4	FT
5	511219-07	WIRE 14GA GXL 125C GREEN	4	FT
4	511219-04	WIRE 14GA GXL 125C BROWN	4	FT
3	511219-02	WIRE 14GA GXL 125C YELLOW	4	FT
2	510833-02	TERMINAL MALE 14-16 #2971962	5	EA
1	510838-01	CONNECTOR 8-WAY, MALE, #2965972	1	EA

TOLERANCES ± J'	DRAWN BY R.L.A.	
NEXT ASSY	APPROVED BY	
TITLE Harness, Extension, Tail Light	PRODUCT LINE	
SCALE 1-2	DATE 07/10/95	DRAWING NUMBER 511263-01
		REV. B
		A

LET DATE	E.C.N.	REVISION RECORD	BY
4/99	4751	Production Release	RA

511473

Weight: 5 Lbs.

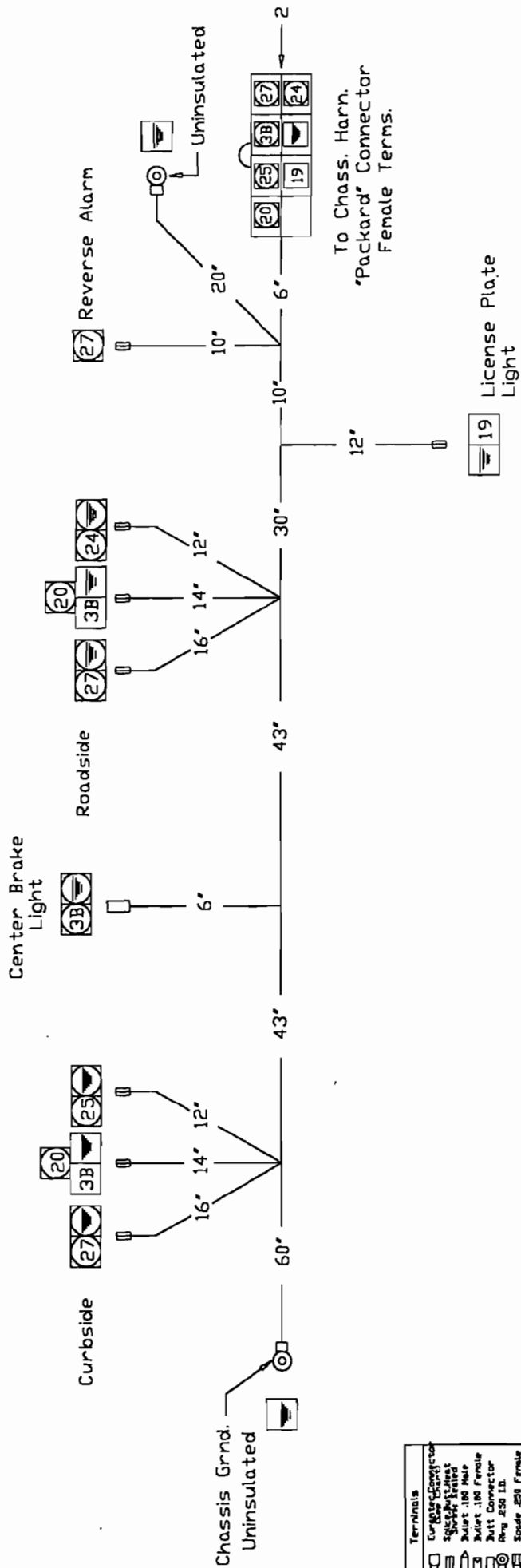

Terminals

⊠	Complete Connector
⊡	Spade Connector
⊢	Spade 250 Amp
⊣	Spade 180 Amp
⊤	Spade 100 Amp
⊥	Spade 75 Amp
⊦	Spade 50 Amp
⊧	Spade 250 Amp
⊨	Spade 180 Amp
⊩	Spade 100 Amp
⊪	Spade 75 Amp
⊫	Spade 50 Amp
⊬	Spade 250 Amp
⊭	Spade 180 Amp
⊮	Spade 100 Amp
⊯	Spade 75 Amp
⊰	Spade 50 Amp
⊱	Spade 250 Amp
⊲	Spade 180 Amp
⊳	Spade 100 Amp
⊴	Spade 75 Amp
⊵	Spade 50 Amp
⊶	Spade 250 Amp
⊷	Spade 180 Amp
⊸	Spade 100 Amp
⊹	Spade 75 Amp
⊺	Spade 50 Amp
⊻	Spade 250 Amp
⊼	Spade 180 Amp
⊽	Spade 100 Amp
⊾	Spade 75 Amp
⊿	Spade 50 Amp

- ⊠ = 20 Ga Wire ⊡ = 14 Ga Wire
- ⊢ = 18 Ga Wire ⊣ = 12 Ga Wire
- ⊤ = 16 Ga Wire ⊥ = 10 Ga Wire
- ⊦ = 8 Ga Wire

3	510834-03	TERMINAL FEMALE 12 #2965143	2 EA
2	510838-02	CONNECTOR 8-WAY, FEMALE, #2965977	1 EA
1	510834-02	TERMINAL FEMALE 14-16 #2965511	5 EA
ITEM	PART NUMBER	DESCRIPTION	QTY UM

TOLERANCES	DRAWN BY	
± 1"	R.L.A.	
NEXT ASSY	APPROVED BY	
TITLE	PRODUCT LINE XL Diesel 390 L/Y Mh.	
	Airstream	
	Harness, Tail Light	

No.	Ga	Color	Function
3B	14	Yel/red	Brake Lamps
19	12	Brown	Clearance Lits.
20	14	Dk. Blue	Tail Lamps
24	14	Yellow	Left Turn Lamp
25	14	Dk. Green	Right Turn Lamp
27	14	Lt. Green	Back-Up Lamps

Note:

- All connectors are wire side view.
- All wire to be, GXL, 125C, U.L./C.S.A. listed.
- Ground wires (⊥) to be white.
- Loom harness.

SCALE	DATE	DRAWING NUMBER	REV.
None	01/15/99	511473	B

511459

WEIGHT: .88 LBS.

LET	DATE	E.C.N.	REVISION RECORD	BY
	12/98	4725	Production Release	RA

CLEARANCE LTS.

TYP. (S) PLACES → 

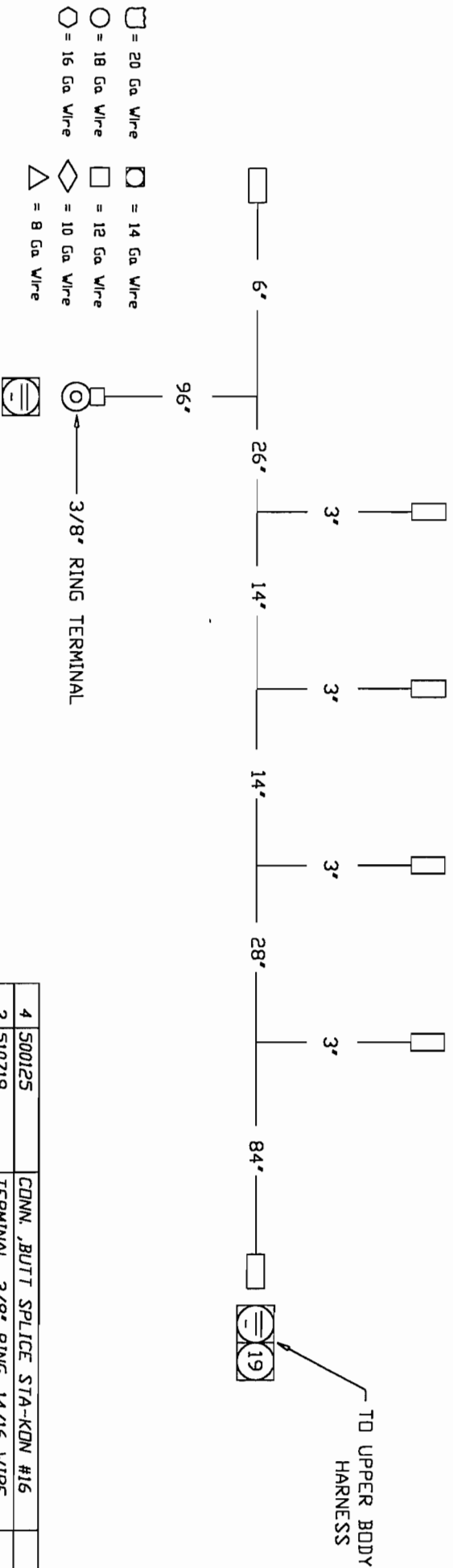

61-H

Terminals	
	Bullet .180 Male
	Bullet .180 Female
	Butt Connector
	Ring .250 I.D.
	Spade .250 Female
	Spade .250 Male
	Coax Connector

- = 20 Ga. Wire
- = 14 Ga. Wire
- = 18 Ga. Wire
- = 12 Ga. Wire
- = 16 Ga. Wire
- = 10 Ga. Wire
- = 8 Ga. Wire

NOTE:
 1. ALL WIRE TO BE TEW 105C, UL/CSSA.
 2. GROUND WIRE TO BE WHITE.

No.	Ga.	Color	Function
19	14	BROWN	CLEARANCE LTS.
	14	White	GROUND

TITLE		Harn., Lt., Clearance, Rear	
SCALE	DATE	DRAWING NUMBER	REV.
1=1	10/29/98	511459	B
TOLERANCES		DRAWN BY	
± .1"		R.L.A.	
NEXT ASSY		APPROVED BY	
FIRST USAGE:		Airstream	
ITEM	PART NUMBER	DESCRIPTION	QTY
4	S00125	CONN., BUTT SPLICE STA-KON #16	6 EA
3	S10719	TERMINAL, 3/8" RING, 14/16 WIRE	1 EA
2	S10537-06	WIRE, 14 GA., 19 STRAND, WHITE	23.4 FT
1	S10537-04	WIRE, 14 GA., 19 STRAND, BROWN	15.4 FT

LEFT HAND SIDE

RIGHT HAND SIDE

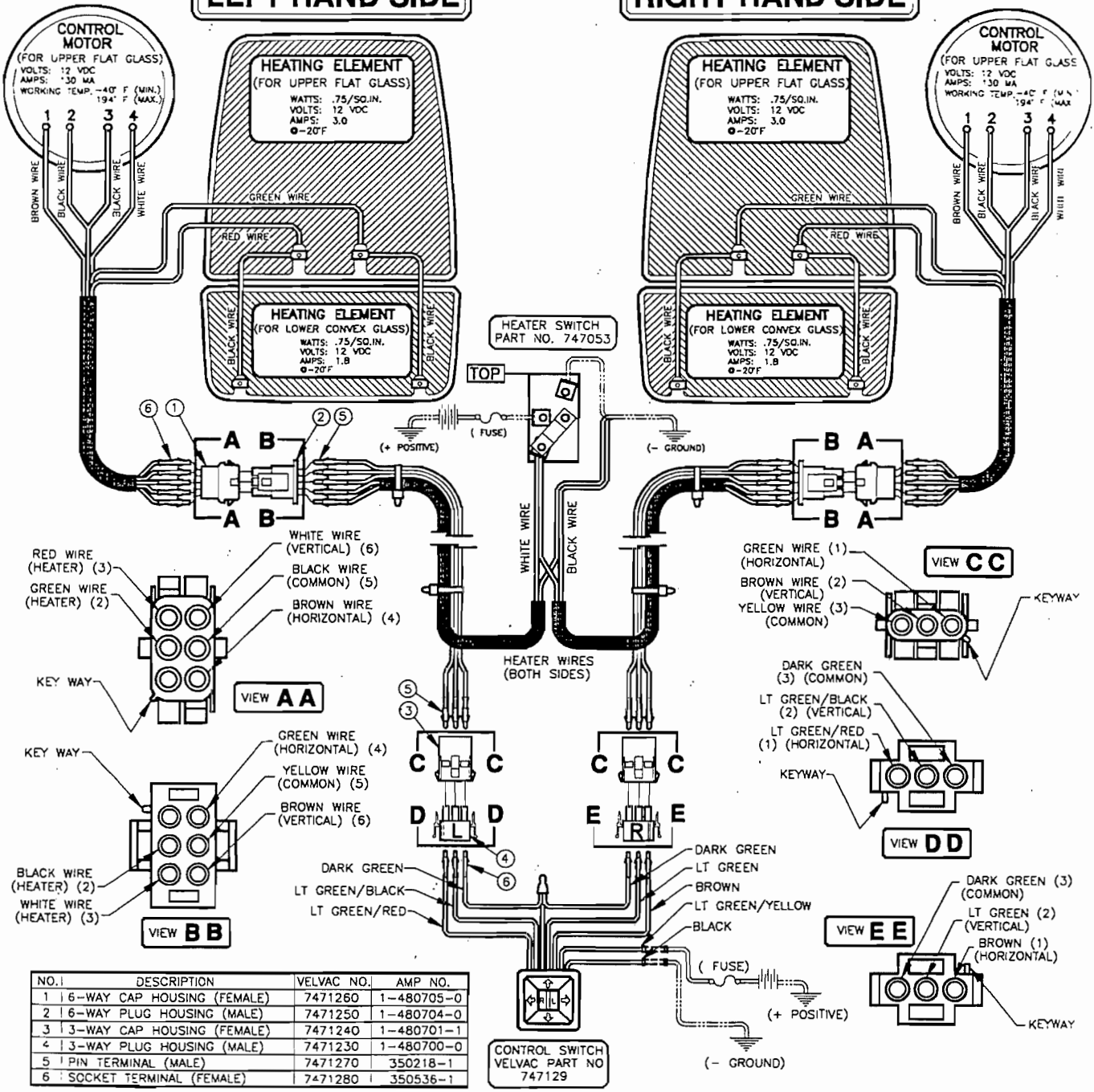

952548

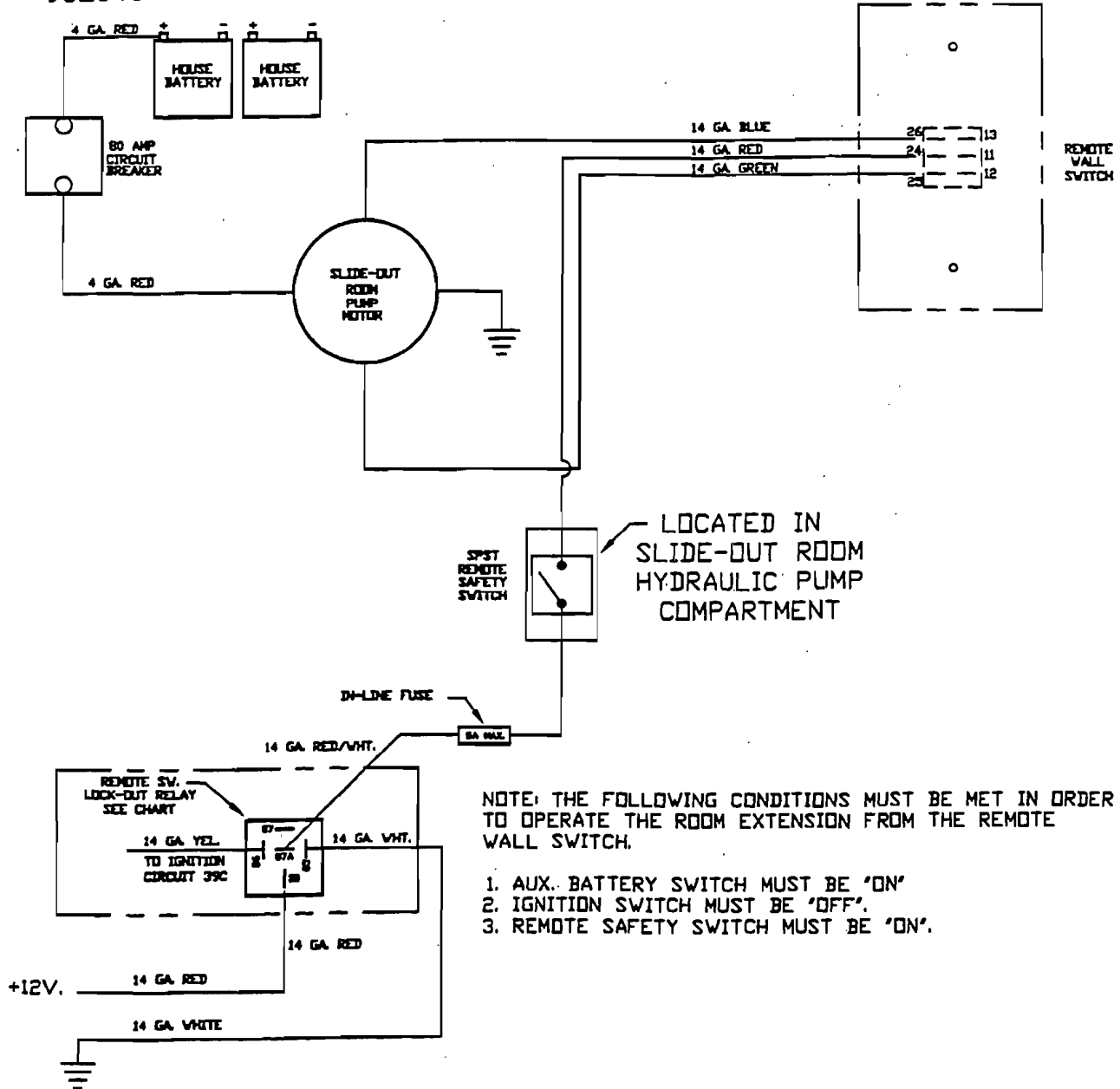

NOTE: THE FOLLOWING CONDITIONS MUST BE MET IN ORDER TO OPERATE THE ROOM EXTENSION FROM THE REMOTE WALL SWITCH.

1. AUX. BATTERY SWITCH MUST BE 'ON'
2. IGNITION SWITCH MUST BE 'OFF'.
3. REMOTE SAFETY SWITCH MUST BE 'ON'.

SLIDE-OUT ROOM RELAY CHART					
RELAY	PIN 30	PIN 85	PIN 86	PIN 87	PIN 87A
REMOTE SV. LOCK-OUT	6 14-RED	⊕ 14-WHITE	14-YEL.	⊕	14-RED/WHT

ITEM	PART NUMBER	DESCRIPTION	QTY	UM
TOLERANCES ±		Airstream	DRAWN BY R.L.A.	
NEXT ASS'Y			APPROVED BY	
PRODUCT LINE <i>34' Cutter W/Slide-Out</i>				
TITLE <i>Lay-Out, Slide-Out Rm. Relays</i>				
SCALE 1=2	DATE 10/05/95	DRAWING NUMBER 952548	B	REV. A

COAX CONNECTIONS

Sensor Antenna

Antenna Power Supply

CONNECTS TO
2ND TV FEED

Front TV

Video Control Center

CABLE
IN

VCR

VCR
OUT

Rear TV

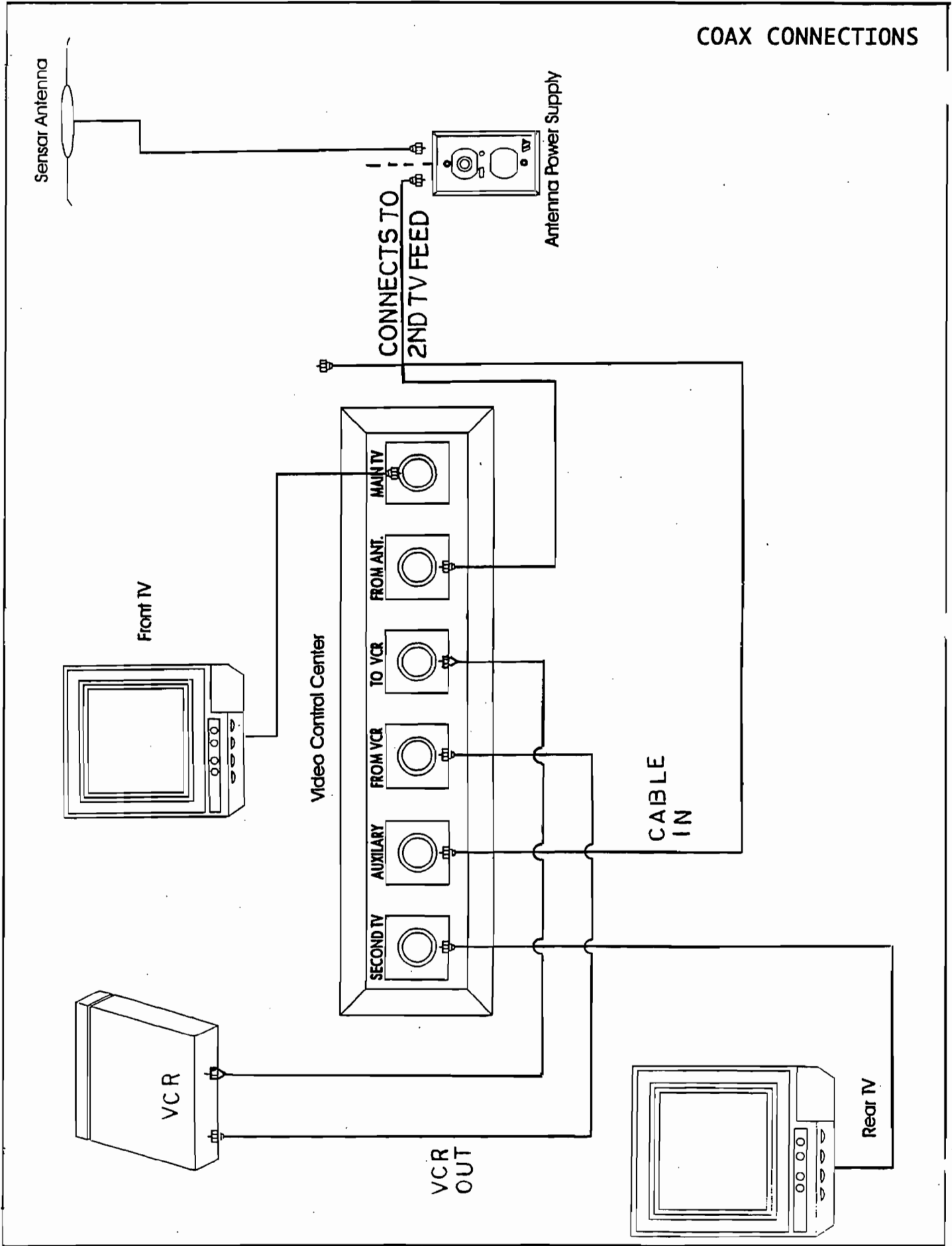

LET	DATE	E.C.N.	REVISION RECORD	BY
	8/94	44626	Production Release	RA

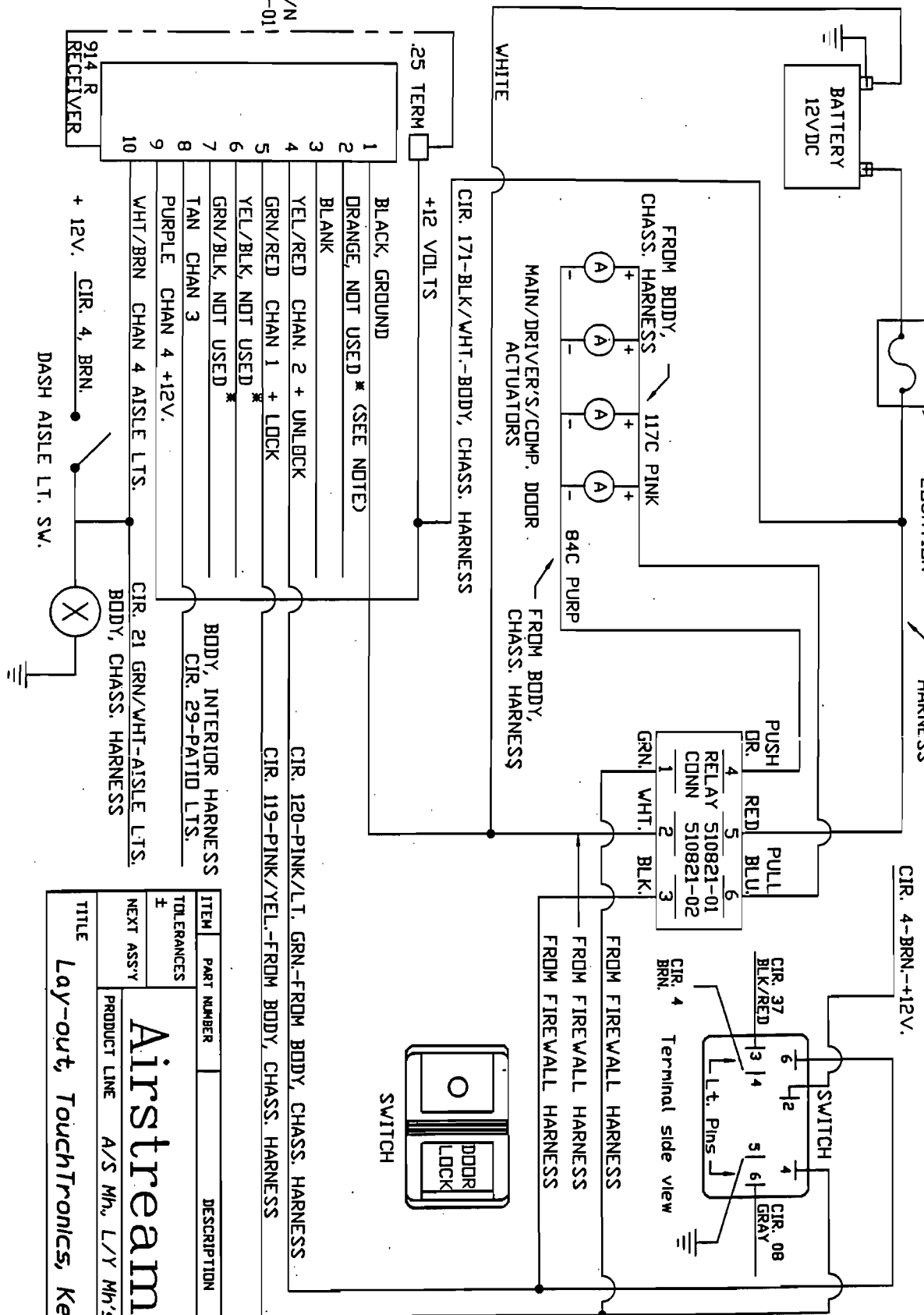

- 1 BLACK, GROUND
- 2 ORANGE, NOT USED * (SEE NOTES)
- 3 BLANK
- 4 YEL/RED CHAN. 2 + UNLOCK
- 5 GRN/RED CHAN 1 + LOCK
- 6 YEL/BLK, NOT USED *
- 7 GRN/BLK, NOT USED *
- 8 TAN CHAN 3
- 9 PURPLE CHAN 4 +12V.
- 10 WHT/BRN CHAN 4 AISLE LTS.

914 R RECEIVER

+12V. CIR. 4, BRN. DASH AISLE LT. SW.

CIR. 21 GRN/WHT-AISLE LTS. BODY, CHASS. HARNESS

CIR. 29-PATID LTS. BODY, INTERIOR HARNESS

CIR. 120-PINK/LT. GRN-FROM BODY, CHASS. HARNESS

CIR. 119-PINK/YEL.-FROM BODY, CHASS. HARNESS

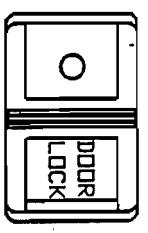

ITEM	PART NUMBER	DESCRIPTION	QTY	UM
TOLERANCES				
±				
NEXT ASSY				
TITLE		Airstream		
PRODUCT LINE		A/S Mh., L/Y Mh's.		
DRAWN BY		Armsstrong		
APPROVED BY				
TITLE Lay-out, TouchTronics, Keyless Entry				

MONITOR PANEL

Ventline
P.O. Box 629
Bristol, Indiana 46507
Phone: 219-848-4491

Operation

To check tank capacities or battery condition, depress the switch marked "test." In order to obtain a true reading on the batteries, you must be unplugged from city power and disconnected from your tow vehicle. On the panel the gauge designated tank 1 is for the black tank and tank 2 indicates the fluid level in your gray tank.

The range exhaust fan has an exterior door that must be unlatched to be effective. You'll see the two small twist latches if you look at the fan from outside the motorhome. In most circumstances you can leave the door unlatched. During storage or adverse weather conditions, latching the door is recommended.

Trouble Shooting Guide

Be sure the wiring to the panel is correct and that the house battery is well charged. All electrical connections must be correct.

NOTE: RV's are subjected to a lot of vibration from traveling on the highways, so always look for broken wires and loose or broken connections.

NOTE: If a RV has exposed holding tanks under the vehicle and the vehicle is operated in the rain, sleet or snow, the panel may show incorrect tank levels due to electrical conductivity on the outside of the tanks. Washing the tanks and sealing the connections on the outside of the well nuts with silicon sealer should correct this condition.

PROBLEM: Fan does not operate.

CAUSE:

- A. No voltage to switch.
- B. Defective switch, defective motor.

REMEDY: 1. Check for voltage, test switch, test motor.

PROBLEM: Fan operates on high speed but not on low speed.

CAUSES: A. Defective circuit board.

REMEDY: 1. Replace circuit board.

PROBLEM: Hood light does not operate.

- CAUSES:**
- A. Burned out bulbs.
 - B. No voltage to switch.
 - C. Defective switch.

- REMEDY:**
- 1. Test for voltage.
 - 2. Test switch.
 - 3. Test bulbs.

PROBLEM: Water pump does not operate.

- CAUSES:**
- A. No voltage to pump.
 - B. Defective switch or pump.
 - C. Pump not grounded.

- REMEDY:**
- 1. Test for voltage at switch.
 - 2. Check ground.

PROBLEM: Water pump operates but red indicator light does not come on.

- CAUSES:**
- A. Faulty LED.
 - B. Faulty circuit board.

- REMEDY:**
- 1. Replace circuit board.

PROBLEM: "E" LED shows but indicator lights for amount of liquid in tank don't show.

- CAUSES:**
- A. Faulty connection in lead to tank.
 - B. Faulty circuit board.

- REMEDY:**
- 1. Check leads and connections at tank.
 - 2. Replace circuit board.

PROBLEM: Condition of battery is not indicated when switch is pushed.

- CAUSES:**
- A. Faulty switch.
 - B. Faulty circuit board.
 - C. Circuit board not grounded.
 - D. Dead battery.

- REMEDY:**
- 1. Test Test switch, check ground.
 - 2. Change circuit board.
 - 3. Charge battery.

PROBLEM: No "E" light on water tanks when switch is pushed.

CAUSES: A. No power to panel.
B. Defective circuit board.

REMEDY: 1. Check fuses and power leads.
2. Repair or replace panel.

PROBLEM: Improper level indication on one or two tanks.

CAUSES: A. Faulty wiring from panel to sensors.
B. Faulty circuit board.
C. Dirty sensors and/or tank.

REMEDY: 1. Check wiring to sensors.
2. Clean sensors and tank.
3. Replace tank sensor harness.
4. Replace or repair circuit board.

PROBLEM: Improper level indication on all water tanks.

CAUSES: A. Faulty circuit board.

REMEDY: 1. Replace or repair circuit board.

PROBLEM: Panel shows LPG tank to be full all of the time.

CAUSES: A. Connection between tank and panel faulty.
B. Poor or no ground between tank and vehicle.
C. Faulty tank sending unit or faulty circuit board.

REMEDY: 1. Check and repair wiring from tank to panel and tank to ground.
2. Repair or replace tank sending unit.
3. Repair or replace circuit board.

PROBLEM: Panel shows LPG tank to be empty all of the time.

CAUSES: A. Short to ground in wire between panel and tank sending unit.
B. Faulty tank sending unit.
C. Faulty circuit board.

REMEDY: 1. Repair shorted wire.
2. Repair or replace sending unit.
3. Repair or replace circuit board.

NOTE: If the wire from the panel is removed from the tank, the panel indicator should show the tank full. If the panel wire to the tank is grounded, the panel should show the tank empty.

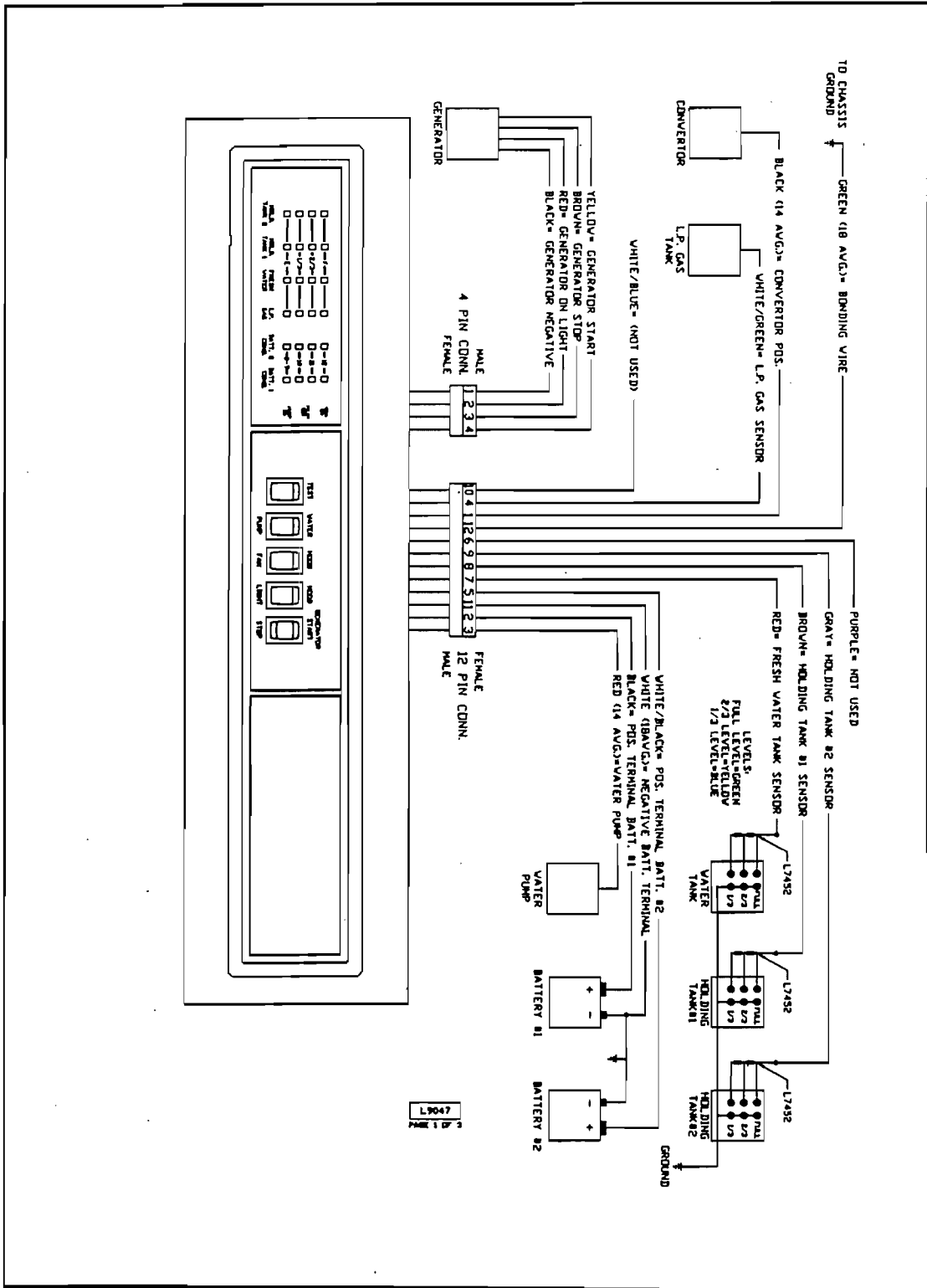

TV ANTENNA

Manufacturer: Winegard Company
3000 Kirkwood Street
Burlington, Iowa 52601
Phone: 800-843-4741

Raising Antenna to Operating Position

Turn elevating crank in "UP" direction until some resistance to turning is noted. Antenna is now in operating position. Check to make sure switch on front TV jack is on.

Rotating Antenna

Make sure antenna is in "UP" position. Pull down on directional handle with both hands until it disengages ceiling plate and rotate for best picture and sound on television set.

Lowering Antenna to Travel Position

Rotate antenna until pointer on directional handle aligns with pointer on ceiling plate.

WARNING: Antenna must be in "down" position while traveling to prevent damage.

Turn elevating crank in the "Down" direction until resistance is noted. Antenna is now locked in travel position.

Checking Operation

1. Tune TV receiver to nearest station and rotate antenna for **lowering Antenna** best picture and sound.
2. Turn off switch on power supply. Picture on TV receiver should be considerably degraded with power off.

DO'S

1. Do check parking location for obstructions before raising antenna.
2. Do carefully raise, lower and rotate - if difficult, check for cause.
3. Do rotate slowly when selecting station and check fine tuning on TV set to make sure it is properly adjusted.
4. Do lower antenna before moving vehicle.

DON'TS

1. Don't force elevating crank up or down. Check for cause of trouble.
2. Don't rotate directional handle hard against stops.
3. Don't travel with lift in up position.
4. Don't leave lift part way up or down.
5. Don't apply sealing compound or paint over top of base plate or anywhere on lift.

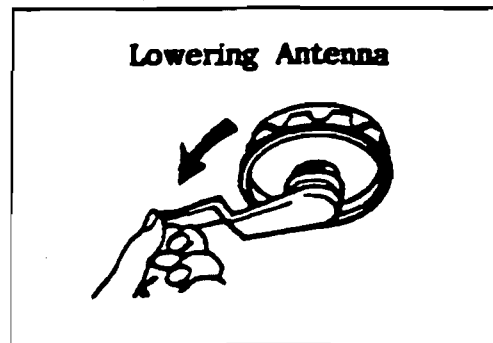
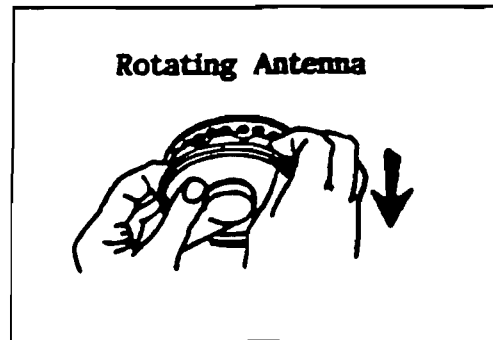
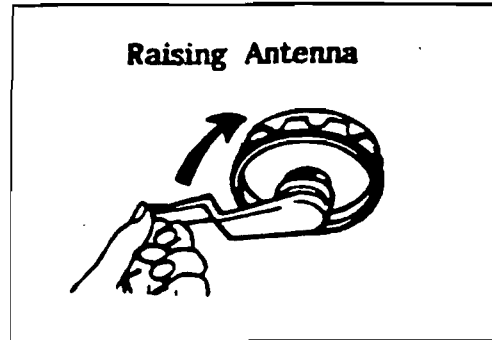

**Maintenance
Lubrication**

To lubricate the elevating gear apply a liberal amount of silicone spray lubricant to the elevating gear with the lift in the down position, then run the lift up and down a few times to distribute lubricant over gears.

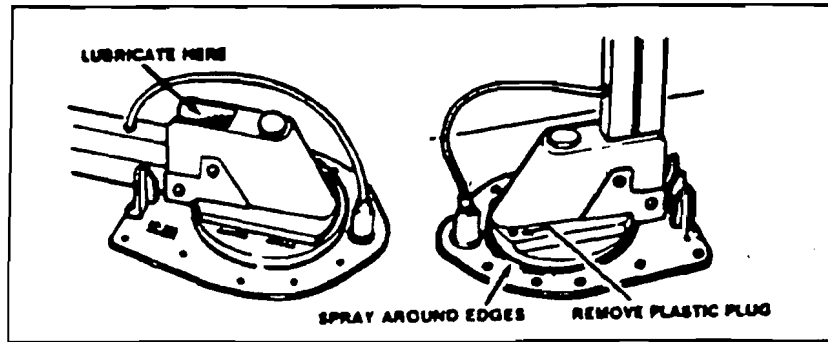

Lubricating Rotating Gear Housing

In the event that rotating the antenna becomes difficult, normal operation can be restored by lubricating the bearing surface between the rotating gear housing and the base plate. Any spray type silicone lubricant may be used.

Elevate antenna and remove set screw from rotating gear housing as shown. Spray lubricant into hole and around edges of gear housing. Rotate gear housing until lubricant coats bearing surfaces and antenna rotates freely.

**Elevating Shaft Worm Gear Assembly
Replacement Procedure**

- STEP 1:** Lower antenna to travel position and refer to drawing to identify parts indicated in steps below.
- STEP 2:** Loosen set screw on elevating crank (#1) and remove crank (#1), spring (#2), directional handle (#3).
- STEP 3:** Go to roof of vehicle and Qs remove retaining ring from pin (#5) holding top elevator tube in rotating gear housing and remove pin.
- STEP 4:** Remove bearing plug (#4) from top of rotating gear housing. Disengage elevating gear (#6) and remove elevating shaft assembly (#7).
- Note:** Make sure all parts below worm gear are removed from rotating gear housing. These include bearing, quad ring and one or two washers.
- STEP 5:** Cut new shaft 1/4" longer than old shaft. See Illus: Discard old bearing plug item (#4).
- STEP 6:** Lubricate worm gear on new elevating shaft assembly with spray silicone lubricant, make sure quad ring, washer and wave washer are on lower bearing and insert assembly in housing.
- STEP 7:** Install new plastic bearing plug in top of housing. Re-engage elevating gear in worm gear. Replace pin and retaining ring.
- STEP 8:** Replace directional handle, spring and elevating crank. Make sure set screw contacts flat on shaft before tightening.

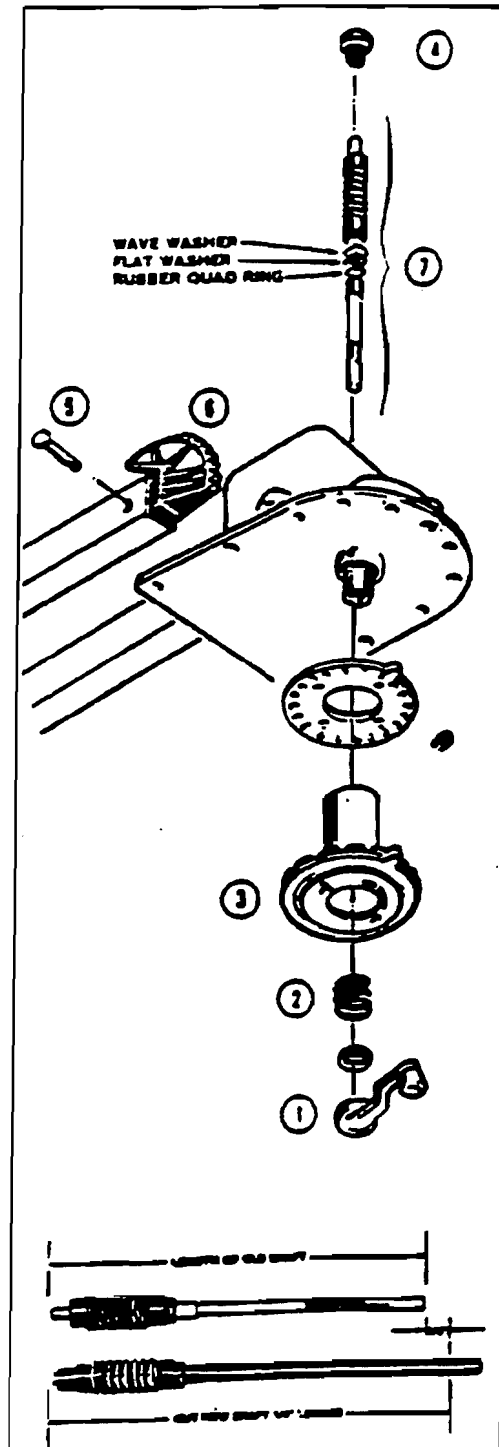

PARTS DESCRIPTION

1. Antenna Head
2. LM-300 Leveling Mount
3. Boot, Coax Cable
4. Pin, Headed/Grooved
5. Ring, Retaining Snap
6. Spacer, Plastic
7. Grommet, Plastic
8. EG-87 Elevating Gear
9. Tube, Square Elevator
10. Elevating Shaft Assy
11. Housing, Rotating Gear
12. Ring, Quad Seal
13. Bearing, Nylon
14. Housing, Base Plate
15. Bearing, Nylon
17. Plate, Ceiling
18. Screw
19. Handle, Directional
20. Spring, Handle
21. Decal, Crank Cover
22. Bearing, Nylon
23. Elevating Crank/Set Screw
27. Boot, Gear Housing
30. Bumper, Rubber
31. Screw

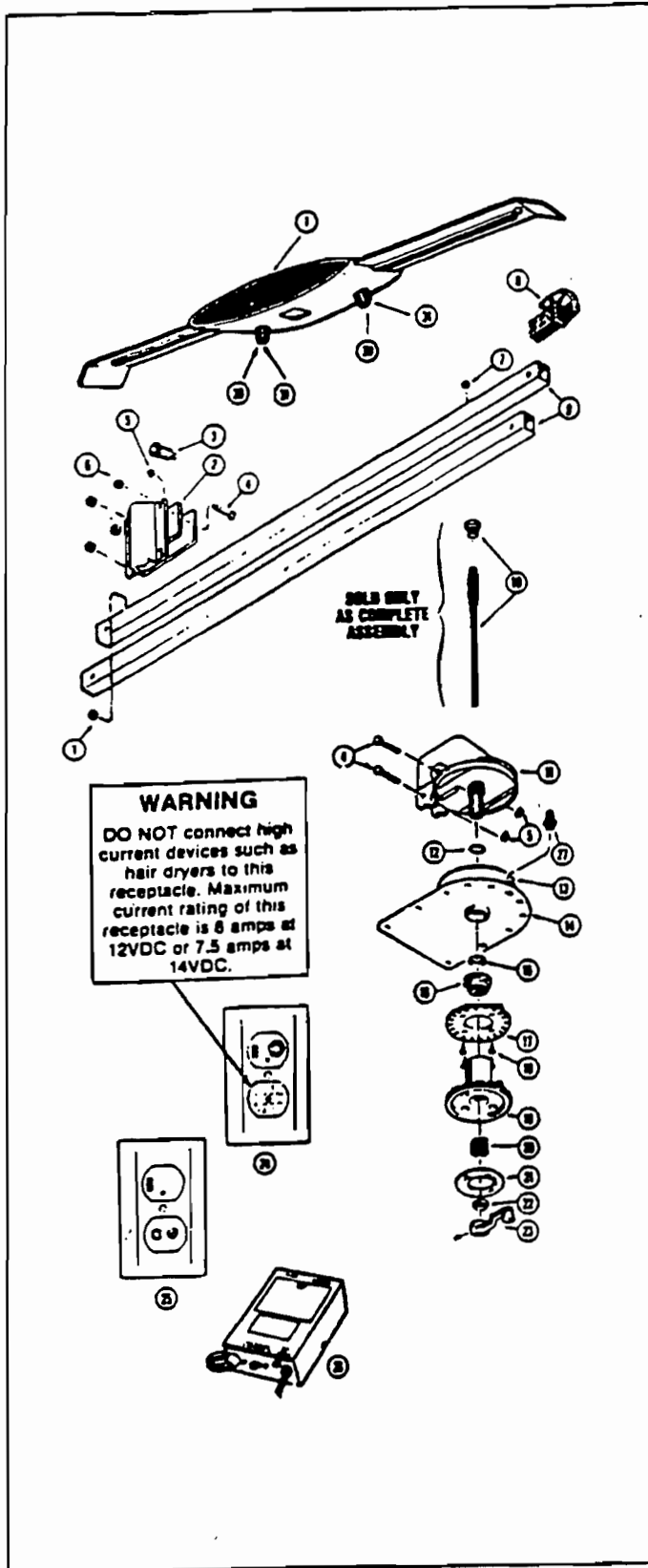

ANTENNA, RADIO, CB, CELLULAR TELEPHONE

Not including the TV antenna, your motorhome may have as many as two other antenna.

The AM/FM **radio antenna** is a solid whip type with a flexible coil base. The coil base certainly helps extend the life of the antenna but hitting low branches and other objects at high speed can lead to severe damage.

The lead-in wire from the **cellular phone** antenna is coiled under the dash behind the kick panel in front of the passenger cab seat. The panel is removed by taking out the screws you can see through the vent grill and there are a couple of screws along the vertical right side of the panel.

SOLAR POWER

The 10 watt solar power system primarily functions as a battery maintainer. Memory functions in radios, locks and many circuit boards each draw power in the milliamp range. If a charge source is not available, even these miniscule power drains will run batteries down in seven to twelve days unless the "kill" switch is turned off. Barring an unusual number of cloudy days the 10 watt system will prevent battery discharge even with the kill switch on.

110 VOLT POWER

The 110-volt system works very much like your home. The circuit breakers, located behind access door in the foot of the rear bed, supply the power to the receptacles and appliances.

If a circuit is over loaded or a short circuit occurs, the breakers will "kick" out. To reactivate the circuits, turn the breaker to off, reduce the load or correct the short, and turn the breaker back to on.

One of the breakers is a GFI (Ground Fault Interrupter) breaker. The intent of this breaker is to sense any loss of ground before a harmful shock could occur, and kick the breaker out. These sensitive breakers are installed in the circuit feeding the bathroom, outside receptacle, and galley area. These are the areas where the use of water or the wet ground could put a person in danger of shock. Since the GFI breaker is so sensitive, it is not unusual to have it kick out for no apparent reason.

GENERATOR

Using the generator is very much like plugging into an external power source. When you start the generator there is a built in delay of about 20-30 seconds before the circuits are switched and all the 110 volt power to your coach is being provided by the generator.

The electrical device that has the delay and switching feature is called the generator switch over relay. The time delay feature allows the generator to reach full operation before it takes the "load". The switching device has two sets of points. It's normally closed so city power coming in goes through the switch and on to the main circuit breakers. When the generator is started and the delay feature is satisfied the switching device goes to the second set of points. This cuts the contact between the city power and the breaker box and makes the contact between the generator and the breaker box.

NOTE: The generator manufacturer provides a operators manual that should be reviewed prior to use.

POWER CORD

The power cord is located on an electrically powered reel in the first compartment behind the roadside rear wheels.

The reel is controlled by a switch marked "in" and "out". You'll find this feature especially helpful in cool weather when the heavy power cord becomes less flexible.

If adapters are required when you plug into city power you'll be losing some power capabilities and won't be able to operate all the appliances at the same time. The washer/dryer, air conditioners, microwave and 110 volt mode on the refrigerator are all heavy load items. The easiest way to cope with the problem is to set the refrigerator on gas then avoid operating the other appliances at the same time.

WARNING: If adapters are required to obtain 110 volt city power it's extremely important that the polarity (ground function) is not lost.

With your motorhome a circuit analyzer was provided. It is usually yellow and triangular shaped with prongs shaped to fit a standard receptacle. Plug this into any receptacle in your coach and it will indicate any polarity or grounding problem.

Loss of ground can be extremely hazardous. You might touch the motorhome and feel a slight tingle (your body has become the ground circuit) or you can receive a severe shock.

NOTES

INVERTER

The inverter in your motorhome is located in the second lower compartment behind the entrance door. When disconnected from 110 volt city power and the inverter is turned on 12 volt DC power from the batteries is inverted to 120 volt AC. The circuits supplied from the inverter are the microwave, front air conditioner and all receptacles on the GFI breaker. Because of the heavy load and long operating times associated with air conditioning it is not recommended the air conditioner be used with the inverter.

OPERATION OF THE INVERTER

Before attempting to operate the inverter you should review the separate Owner's Manual provided by Trace. Start the unit by depressing the Start/Stop switch. It will return to a neutral position once released.

Note: The Lamp will momentarily flash as the unit runs through its normal diagnostic sequence.

The Lamp indicates when power is being supplied to the receptacles. If no load is sensed the inverter will not turn on.

INVERTER OPERATING TIMES

Your Airstream motorhome is equipped with a TRACE model V2512 Inverter. This inverter will supply you with quiet AC power to operate your electrical appliances. Inverters convert 12 volt direct current (DC) into 120 volt alternating current (AC).

There are three factors to consider when you select the appliances that you would like to operate with the inverter. Those considerations are: battery reserve capacity, maximum wattage and typical operating times of appliances. Good estimating of these factors will assure you have plenty of resources to operator your appliances.

BATTERY RESERVE CAPACITY

Batteries store the energy necessary for the inverter to convert DC to AC power. Your Airstream motorhome has four Group 27 HD batteries dedicated to the inverter's use. Battery performance is affected by temperature and age. Batteries operate best when the temperature is about 77° F. If the batteries are hotter than, or colder than this temperature, performance is reduced. As batteries age, they lose some of their performance, or ability to store energy.

MAXIMUM WATTAGE

Your inverter can provide a surge of *8000 watts of power for one minute and 2500 watts continuously. This means that your use of 120 volt appliances from inverter power can total up to 2500 watts simultaneously depending on the usage time.

ESTIMATING YOUR OPERATING TIMES

With your Airstream inverter installation using 4 Group 27 HD batteries in good condition and fully charged you will find that the total capacity (running times) will depend on the total wattage load of the devices you are powering. In general, the running time is proportionate to the wattage.

Using the following tables, you can estimate which combinations of appliances you may operate. Table 1 indicates the typical wattage of various appliances.

*Largest bank of incandescent light bulbs that the inverter can start simultaneously and operate for at least one minute.

Table 1 - Typical Battery Draw of Common Appliances

Appliance	Watts	Amps	Battery Draw in Amp Hours for Run Time of:						
			5 min	15 min	30 min	1 Hr	2 Hr	4 Hr	8Hr
B&W 12" TV	40	0.3	<1	1	2	4	7	15	30
Stereo or VCR	50	0.4	<1	1	2	5	9	19	37
Light Bulb	60	0.5	<1	2	3	6	11	22	44
TV-19" Color	150	1.3	1	3	7	14	28	56	111
*Refrigerator 3 cu ft	180	1.5	<1	1	3	6	11	22	44
Computer	200	1.7	2	5	9	19	37	74	148
Blender	400	3.3	3	9	19	37			
*Refrigerator 12 cu ft	480	4.0	1	4	7	15	3	59	119
3/8" Drill	500	4.2	4	12	23	46			
Microwave	800	6.7	6	19	37	74			
Hair Dryer or Iron	1000	8.3	8	23	46	93			
Vacuum or Coffee Maker	1200	10.0	9	28	56	111			
Microwave Full Size	1500	12.5	12	35	69	139			
12 VOLT SYSTEM									

Notes: If the current draw at 120 VAC is known, then the battery amperage at 12VDC will be 10 times the AC amperage divided by the efficiency (90% in this table).

Motors are normally marked with their running rather than their starting current. Starting current can be five times running current.

***Refrigerators and ice makers typically run about 1/3 of the time. Therefore, their average battery current draw is 1/3 what their amp rating would indicate.**

TROUBLE SHOOTING GUIDE

SYMPTOMS	PROBLEM	REMEDY
No power output and no warning LED's	Battery voltage at the inverter's terminals is too high or low	Check the battery condition
	Battery overdischarge protection circuit set too high	Lower cutout voltage an/or battery bank size setting
	Load too small for Search Mode circuit to detect	Reduce search threshold setting or defeat the Search Mode
	ComPort Accessories are improperly installed	Re-install or remove options from the ComPort
No power output and warning LED/s "ON"	High or Low Battery LED "ON"	Check the battery voltage at the inverter terminals
	Overload LED in "ON"	Remove loads from the inverter and restart
	High Temp Led in "ON"	Remove loads and let the inverter cool down before restarting
Power output is low and inverter turns loads on and off	Low battery	Check charge and condition of batteries
	Loose or corroded battery connections	Check and clean all connections
	Loose AC output connections	Check all AC output connections
Inverter clicks every 10 to 15 seconds interrupting power	Output of inverter wired back to the input (standby model only)	Check for proper AC input and output wiring
Charger is inoperative or intermittent	AC input voltage does not match inverter spec	Check AC input for proper voltage and frequency of your model
	Charger controls improperly set	Refer to Owner's Manual for proper setting of battery charger parameters
Low charge rate	Low <u>peak</u> AC input voltage (164 volts peak required for full charger output)	Use larger generator, speed up generator, check AC input wiring size, adjust charge rate, cable too small or too long
	AC current too small to handle load	Reduce charge amps setting and/or shed pass through loads
Low AC output voltage	Measuring with the wrong type voltmeter	Voltmeter must be a true RMS reading meter (most are not)
Low surge power	Weak batteries, battery cables too small or too long	Refer to cable and battery recommendations in owner's manual

952623

MAIN PANEL

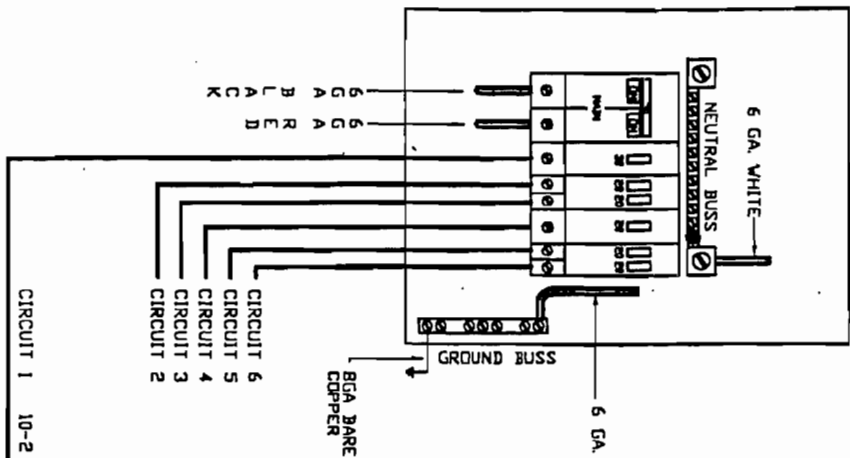

- CIRCUIT 1, 30 AMP HACR BREAKER, 10-2 ROMEX W/GROUND, LEG 1, SUB-PANEL.
 - CIRCUIT 2, 20 AMP HACR BREAKER, 12-2 ROMEX W/GROUND, LEG 2, REAR A/C.
 - CIRCUIT 3, 20 AMP HACR BREAKER, 12-2 ROMEX W/GROUND, LEG 2, BEDROOM.
 - CIRCUIT 4, 20 AMP HACR BREAKER, 12-2 ROMEX W/GROUND, LEG 1, FRT. A/C.
 - CIRCUIT 5, 20 AMP HACR BREAKER, 12-2 ROMEX W/GROUND, LEG 2, WASHER/DRYER RECEPT.
 - CIRCUIT 6, 20 AMP HACR BREAKER, 12-2 ROMEX W/GROUND, LEG 2, WATER HEATER.
- NOTE:
WITH 50 A. GENERATOR WIRES
TO THE MAIN 50 A. BREAKER ARE 4 GA.

CIRCUIT 1A, 20 AMP BREAKER, 12-2 ROMEX W/GROUND, MICROWAVE.
 CIRCUIT 1B, 20 AMP BREAKER, 12-2 ROMEX W/GROUND, BATH (GFI RECEPT), OUTSIDE, REFER.
 GALLEY AREA, DINETTE, END TABLES, AND FRONT & REAR TV RECEPTS.

INVERTER OPTION



SQUARE "D" LOAD CENTER
 CATALOG NO. Q06-12L100T
 SERIES G1
 TYPE 1 ENCLOSURE
 120/240V. A.C. 1 PH. 3W.
 MAINS 100 MAX.
 UL/CSA CERTIFIED

LET	DATE	E.C.N.	REVISION RECORD	BY
			PRODUCTION RELEASE	TC

ITEM	PART NUMBER	DESCRIPTION	QTY	U/M
TOLERANCES				
NEXT ASSY				
TITLE		DRAWN BY		
SCALE		APPROVED BY		
DATE		DRAWING NUMBER		
2/2/98		952623		
TITLE		REV.		
110V. PANEL-50 AMP WITH INVERTER		B		

LOCATING SHORTS AND OPENS

The key in locating shorts and opens is isolation. The first step is to isolate the circuit with the short or open. The second step is to then isolate the section of the circuit with the fault. Once the section is identified, the specific problem can be located. The cause may be a loose or corroded connection, cut wire, worn insulation, defective component, etc. The following procedure is one method for isolating shorts and opens.

SHORTS

1. Isolate the circuit which has the short by noting which circuit breaker has tripped.
2. Disconnect the power inlet cord from the power source.
3. Using the 120V schematic as a reference, disconnect outlet boxes one at a time starting at the box furthest from the distribution panel. After disconnecting each box, check for continuity between the black wire and ground or common (white) wire on the distribution panel side of the circuit. When a continuity light or ohmmeter indicates no continuity, the short is either in the receptacle just removed or the section of Romex wire between this receptacle and the previous receptacle removed.
4. Examples of a short are: A) The black wire of the 120V system contacting the white wire, bare wire or grounded surface. B) An internal short in a 120V appliance.

Any damaged wire must be replaced. The National Electrical Code does not permit splicing 120V wiring outside an outlet box or junction box. Also, the wire must not be exposed to an area such as a sharp metal edge which may damage the wire.

OPENS

1. Check all receptacles and components for voltage on the circuit which has the open.
2. If all receptacles and components of the circuit are without power, begin to look for open in the distribution panel.
3. Inspect for loose or corroded connections and a faulty circuit breaker.
4. Check for power on both ends of circuit breaker. If there is no power on the inlet side of the circuit breaker, the open is between the power cord's male connector and the distribution panel.
5. The open can be isolated by noting the outlets which do not have power. Example: If the bath outlet in the rear bath model has power and the converter has no power, the open is between the bath outlet and converter outlet.
6. Examples of an open are: A) Loose or corroded connections. B) A wire disconnected from a terminal. C) Contacts in the circuit breaker which do not make contact. D) A broken wire.

50 A. POWER CORD
23' OF USABLE LENGTH
10-3

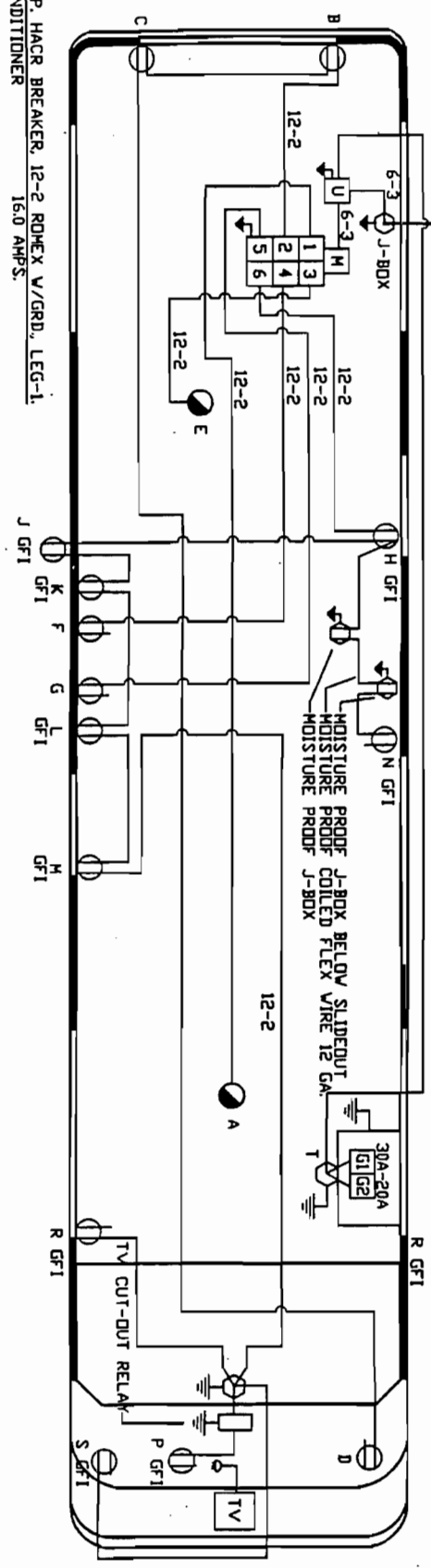

LET	DATE	E.C.N.	REVISION RECORD	BY
	6/95		Production Release	TC

- CIRCUIT 1. 20 AMP. HACR BREAKER, 12-2 ROMEX V/GRD, LEG-1.
- A. FRONT AIR CONDITIONER 16.0 AMPS.

- CIRCUIT 2. 20 AMP. HACR BREAKER, 12-2 ROMEX V/GRD, LEG-1.
- B. ROADSIDE BEDROOM RECEPT 1.0 AMPS.
- C. CURBSIDE BEDROOM RECEPT 1.0 AMPS.
- D. CONVERTER RECEPT 8.0 AMPS.
- TOTAL 10.0 AMPS.

- CIRCUIT 3. 20 AMP. HACR BREAKER, 12-2 ROMEX V/GRD, LEG-2.
- E. REAR AIR CONDITIONER 12.0 AMPS.

- CIRCUIT 4. 20 AMP. HACR BREAKER, 12-2 ROMEX V/GRD, LEG-2.
- F. MICROWAVE OVEN RECEPT 12.0 AMPS.

- CIRCUIT 5. 20 AMP. GFI BREAKER, 12-2 ROMEX V/GRD, LEG-1.
- G. COFFEE MAKER 7.2 AMPS.

- CIRCUIT 6. 15 AMP. GFI BREAKER, 12-2 ROMEX V/GRD, LEG-2.
- H. BATH 1.0 AMPS.
- J. OUTSIDE RECEPT 1.0 AMPS.
- K. REFER RECEPT 2.7 AMPS.
- L. GALLEY RECEPT 1.0 AMPS.
- M. GALLEY RECEPT 1.0 AMPS.
- N. DINETTE 1.0 AMPS.
- P. FRONT TV V/IGNITION INTERLOCK 0.7 AMPS.
- R. PASSENGER AREA RECEPT 1.0 AMPS.
- S. VCR RECEPT 0.5 AMPS.
- TOTAL 9.9 AMPS.

GENERATOR CIRCUITS: THE GEN SET COMES EQUIPPED WITH A 30 AND 20 AMP. BREAKER. THE WIRES COMING FROM THE BREAKERS ARE STRANDED COPPER AND ARE RUN IN FLEXIBLE, MOISTURE-PROOF CONDUIT TO J-BOX 'T'. THE GENERATOR WIRES ARE JOINED TO A 10-3 ROMEX V/GRD WIRE IN THE J-BOX AS FOLLOWS: THE 10 GA. STRANDED 'HOT' WIRE FROM THE 30 AMP BREAKER IS CONNECTED TO THE BLACK WIRE OF THE 10-3 ROMEX. THE STRANDED 12 GA. 'HOT' WIRE FROM THE 20 AMP. BREAKER IS CONNECTED TO THE RED WIRE OF THE 10-3 ROMEX. THE STRANDED, WHITE, 'NEUTRAL' WIRES FROM THE GENERATOR BREAKERS CONNECT WITH THE WHITE WIRE OF THE 10-3 ROMEX. THE STRANDED, GREEN, 'GROUND' WIRES FROM THE GEN. BREAKERS CONNECT WITH THE SOLID COPPER GROUND WIRE OF THE 10-3 ROMEX. THE 10-3 ROMEX V/GRD. IS RUN TO AUTOMATIC SWITCHOVER RELAY 'U' WHICH WILL OVERRIDE SHORELINE WHEN THE GENERATOR IS OPERATING. FOR DETAILS OF THE AUTOMATIC SWITCHOVER RELAY, SEE DWG. 952459.

ITEM	PART NUMBER	DESCRIPTION	QTY	UM
TOLERANCES				
±				
NEXT ASS'Y				
PRODUCT LINE		34'SB CUTTER W/SLIDEOUT	DRAWN BY T.C.	
TITLE		110V. Lay-out, 50 AMP.	APPROVED BY	
SCALE	DATE	DRAWING NUMBER	REV.	
1=32	05/31/95	952539	B	

LET DATE	E.C.N.	REVISION RECORD	BY
9/96		Production Release	TC

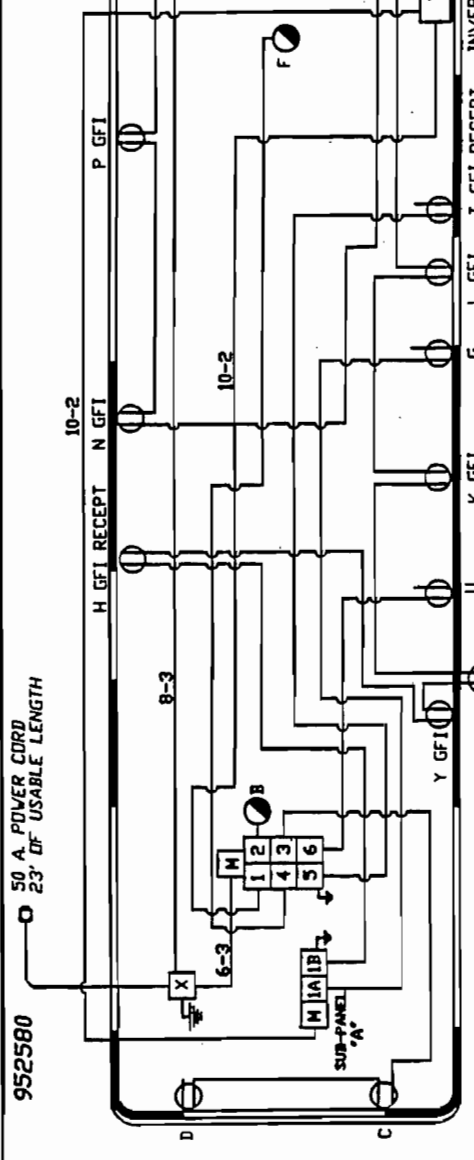

952580

50 A. POWER CORD
23' OF USABLE LENGTH

MAIN-50 AMP. BREAKER

CIRCUIT 1. 30 AMP. HACR BREAKER, 10-2 ROMEX W/GRD, LEG-1.

A. SUB-PANEL VIA INVERTER 'V' 30.0 AMPS.

CIRCUIT 2. 20 AMP. HACR BREAKER, 12-2 ROMEX W/GRD, LEG-2.

B. REAR AIR CONDITIONER 16.0 AMPS.

CIRCUIT 3. 20 AMP. HACR BREAKER, 12-2 ROMEX W/GRD, LEG-2.

C. ROADSIDE BEDROOM RECEPT 1.0 AMPS.

D. CURBSIDE BEDROOM RECEPT 1.0 AMPS.

TOTAL 2.0 AMPS.

CIRCUIT 4. 20 AMP. HACR BREAKER, 12-2 ROMEX W/GRD, LEG-1.

F. FRONT AIR CONDITIONER 16.0 AMPS.

CIR. 5. 20 AMP. HACR BREAKER, 12-2 ROMEX W/GRD, LEG-1.

T. COFFEE MAKER (GFIC RECEPT) 8.3 AMPS.

CIRCUIT 6. 20 AMP. HACR BREAKER, 12-2 ROMEX W/GRD, LEG-2.

U. WASHER/DRYER RECEPT 12.8 AMPS.

CIR. 1B. 15 AMP. BREAKER, 12-2 ROMEX W/GRD.

H. BATH (GFIC RECEPT) 1.0 AMPS.

J. OUTSIDE RECEPT 1.0 AMPS.

K. REFER 3.5 AMPS.

L. GALLEY RECEPT 1.0 AMPS.

M. CURBSIDE END TABLE RECEPT 1.0 AMPS.

N. DINETTE RECEPT 1.0 AMPS.

P. ROADSIDE END TABLE RECEPT 1.0 AMPS.

R. FRT. TV V/AUTO CUT-OFF RELAY 0.7 AMPS.

S. VCP RECEPT 0.23AMPS.

Y. REAR TV RECEPT 0.7 AMPS.

TOTAL 11.13 AMPS.

GENERATOR CIRCUITS: THE GEN SET COMES EQUIPPED WITH A 35 AMP. SINGLE THROW, DOUBLE POLE BREAKER. WIRES COMING FROM THE BREAKER ARE STRANDED COPPER AND ARE RUN IN FLEXIBLE, WATER TIGHT CONDUIT TO J BOX 'V'. THE GENERATOR WIRES ARE JOINED TO A 8-3 ROMEX W/GROUND WIRE IN THE J BOX AS FOLLOWS: ONE 8 GA. STRANDED 'HOT' WIRE FROM THE 35 AMP. DOUBLE POLE BREAKER IS CONNECTED TO THE BLACK WIRE OF THE 8-3 ROMEX. THE OTHER STRANDED, 8 GA. 'HOT' WIRE FROM THE 35 AMP. DOUBLE POLE BREAKER IS CONNECTED TO THE RED WIRE OF THE 8-3 ROMEX. THE STRANDED, WHITE, NEUTRAL WIRE FROM THE GENERATOR CONNECTS WITH THE WHITE WIRE OF THE 8-3 ROMEX. THE STRANDED, GREEN, GROUND WIRE FROM THE GENERATOR CONNECTS WITH THE COPPER GROUND WIRE OF THE 8-3 ROMEX. THE 8-3 ROMEX W/GROUND IS RUN TO AUTOMATIC SWITCHOVER RELAY 'X' WHICH WILL OVERRIDE SHORELINE AND INVERTER WHEN THE GENERATOR IS OPERATING.

INVERTER CIRCUIT: WHEN THERE IS POWER AVAILABLE AT THE MAIN PANEL, THE INVERTER'S 30 A. AUTO. TRANSFER RELAY CLOSES, CONNECTING THE MAIN PANEL TO SUB-PANEL 'A'. WHEN THERE IS NO AC PRESENT AT THE MAIN PANEL, THE RELAY OPENS AND THE INVERTER SUPPLIES POWER TO SUB-PANEL 'A'. FOR DETAILS OF THE DISTRIBUTION PANELBOARD AND SWITCHOVER BOX WIRING SEE DRAWING 952564C.

ITEM	PART NUMBER	DESCRIPTION	QTY	UM
TOLERANCES				
±				
NEXT ASSY				
PRODUCT LINE 35' CUTTER PUSHER				
TITLE 50 A. 110V LAYOUT WITH INVERTER				
SCALE NONE				
DATE 9-11-96				
DRAWING NUMBER 952580				
REV. B				

Airstream

APPLIANCES

AIR CONDITIONER

Manufacturer: Dometic Sales Corporation
2320 Industrial Parkway
P.O. Box 490
Elkhart, IN 46515
Phone: 219-295-5228

Note: Review the air conditioning literature supplied in your Owner's Packet before proceeding.

The roof air conditioner used on Airstream motorhomes is one of the most popular on the market today. In your Owner's Packet is a set of literature covering all operating and maintenance instructions. If the literature is misplaced, please contact the air conditioner manufacturer or your Airstream dealer for replacement. A detailed service guide may be ordered from the manufacturer.

The voltage to the air conditioner is critical. We commonly refer to 110 or 120 volts, but a check with a volt meter may find voltage much lower. Your air conditioner will probably not function if the current drops below 105 volts. Low voltage is usually associated with older or poorly maintained trailer parks, but many people have found their homes, built only twenty or thirty years ago, may not be capable of operating the air conditioner on some receptacles. Parking your motorhome so the power cord can be plugged into a receptacle close to the fuse or circuit breaker box can alleviate the problem. Avoid extension cords and adapters whenever possible. If an extension cord must be used, it should be as short and heavy as possible to provide the most current to the air conditioner.

If high temperatures are expected, you should make an effort to park in a shaded area. Starting the air conditioner early in the morning also helps. It is much easier to hold a comfortable temperature than it is to lower the temperature after the interior of the motorhome is already hot.

FURNACE

Manufacturer: Hydro Flame Corporation
1874 South Pioneer Road
Salt Lake City, UT 84104
Phone: 801-972-4621

The manufacturer of the furnace in your motorhome has been well known in the RV industry for many years. The furnace burns LP gas, and is powered by 12 volt current from the battery or power converter when plugged into city power. Operating instructions are located in your Owners Packet. If they should become misplaced new literature can be ordered direct from the manufacturer or your Airstream dealer. The manufacturer also offers a detailed service guide for your furnace.

WARNING: Carefully read all the manufacturer's instructions prior to operating. NEVER store flammable material next to the furnace.

If warranty service is required use only a service location recommended by the furnace manufacturer or your Airstream dealer.

REFRIGERATOR

Manufacturer: The Dometic Corporation
509 South Poplar St.
LaGrange, IN 46761
Phone: 219-463-4850

In an absorption refrigerator system, ammonia is liquefied in the finned condenser coil at the top rear of the refrigerator. The liquid ammonia then flows into the evaporator (inside the freezer section) and is exposed to a circulating flow of hydrogen gas, which causes the ammonia to evaporate, creating a cold condition in the freezer.

The tubing in the evaporator section is specifically sloped to provide a continuous movement of liquid ammonia, flowing downward by gravity through this section. If the refrigerator is operated when it is not level and the vehicle is not moving, liquid ammonia will accumulate in sections of the evaporator tubing. This will slow the circulation of hydrogen and ammonia gas, or in severe cases, completely block it, resulting in a loss of cooling.

Any time the vehicle is parked for several hours with the refrigerator operating, the vehicle should be leveled to prevent this loss of cooling. The vehicle needs to be leveled only so it is **comfortable to live in** (no noticeable sloping of floor or walls).

When the vehicle is moving, the leveling is not critical as the rolling and pitching movement of the vehicle will pass to either side of level - keeping the liquid ammonia from accumulating in the evaporator tubing.

OPERATION

The refrigerator requires 12 volt current to operate even if running on LP or 110 volt modes. The 12 volt is used to power the circuit board that directs the refrigerator functions. When running in a mode such as LP, it means the heat source, by far the largest power requirement, to evaporate the ammonia is being provided by an LP gas burner.

WARNING: Most LP gas appliances used in recreational vehicles are vented to the outside of the vehicle. When parked close to a gasoline pump, it is possible that gasoline fumes could enter this type of appliance and ignite the burner flame, CAUSING A FIRE OR AN EXPLOSION.

RANGE AND OVEN

Manufacturer: Maytag Customer Service
Maytag Customer Assistance
P.O. Box 2370
Phone: 1-800-544-5513

People using gas ranges in their home will find little difference in the operation of the range in the trailer. Other customers, used to electric ranges may be a little apprehensive at first; but, will quickly gain confidence. The basic operation of the gas ranges have been the same for many years, but please be sure to read all the directions furnished by the manufacturer and located in the Owner's Packet. Excellent service and parts manuals are available from the manufacturer.

WARNING: The operation manual for the range is titled "Maytag RV Cooking Appliances". If this has not been provided with your trailer, contact the manufacturer listed at the top of the page to obtain. Their manual contains specialized warnings and cautions that should be reviewed prior to operating the appliance.

MICROWAVE OVENS

Only federally certified technicians are permitted to service microwave ovens. For this reason the only service instructions contained in this manual are for removal of the complete oven. If you have a microwave problem please contact the appropriate manufacturer.

Magic Chef
28812 Phillips Street
Elkhart, Indiana 46514
219-264-9578

Sharp Electronics Corporation
10 Sharp Plaza
Paramus, New Jersey 07652
201-5112-0055

Litton
2530 North 2nd Street
Minneapolis, Minnesota 55411
605-336-5377

Quasar
Division of Matsushia Elec. Corp
1325 Pratt Blvd.
Elk Grove Village, IL 60007
201-348-9090

Airstream has used two different methods of holding the ovens in place. The most common is a set screw configuration where two bolts apply downward pressure on top of the range. The bolts can be found in the cabinet directly above the oven, and out toward the front. Back them out a few turns and the front of the oven can be lifted up and out over the lower ledge.

The second method was to slide a piece of 3/4" pine board under the microwave in front of the rear supports. Once in place screws were run up through the bottom shelf into the 3/4" pine.

You will note neither method makes any holes in the microwave cabinet. The microwave is simply captured in its cabinet. Usually you will be able to move the microwave around in the cabinet, but it won't come out.

WATER HEATER

Manufacturer: Atwood Mobile Products
4750 Hiawatha Drive
P.O. Box 1205
Rockford, Illinois 61105
Phone: 815-877-7461

Note: Review the water heater literature supplied in your Owner's Packet before proceeding.

CAUTION: Hydrogen gas can be produced in a hot water system served by this heater that has not been used for a long period of time (generally two weeks or more). Hydrogen gas is extremely flammable. To reduce the risk of injury under these conditions, it is recommended that the hot water faucet be opened for several minutes at the kitchen sink before using any electrical appliance connected to the hot water system. If hydrogen is present there will probably be an unusual sound such as air escaping through the pipe as the water begins to flow. There should be no smoking or open flame near the faucet at the time it is open.

Electronic Ignition

The switch used to light your electronic ignition water heater is located in the bathroom above the lavatory top. When the switch is turned on, the red light will come on indicating the "try" mode is in effect. Normally the burner will ignite in just a few seconds, and the light will go out. If your LP system hasn't been used for some time, the system may go into safety lock-out (about 20 seconds) before the air is all expelled from the lines. Turning the switch off for 30 seconds, then back on, reinstates the "try" mode. (See Note below.)

Principle of Operation

When the switch is turned on, power is supplied to the thermostat (located inside the junction box at the back of the water heater). When the thermostat senses the water in the tank requires heat (below 120°F), its contacts close and complete the circuit to the circuit board. This will energize the coils in the dual solenoid gas valve, allowing gas to flow out of the main burner orifice, mix with air at the ventura (air adjusting slots), then flow out the end of the main burner.

Simultaneously the coil on the circuit board provides a high voltage current to reach the spark probe at the main burner. This ignites the gas. When the flame is sensed by the probe, current is conducted to the relay and the valve remains energized. Sparking ceases when the electrode to ground current path is altered by the presence of flame. The water heating process begins. When the water in the tank drops below 120°F, the process will automatically repeat itself.

Note: A complaint sometimes received at Airstream is the fact the water heater will not light for a while when the motorhome is first parked. The explanation is easy. The water is already hot! The motorhome water heater has a heat exchanger plumbed into the engine radiator system. As you are driving the water is being heated without your having to do a thing.

SAFETY

If your water system is full and cold and the water heater is ignited the system can see pressures as high as 160 psi before the relief valve starts to open. Since the water system normally operates in the 40 psi range the water expanding does pose unusual stress on the system. This normally does not cause any problems, but the stress is easily alleviated. As the water is heating just open any faucet and run as little as a cup of water. Just removing this small amount of water reduces the pressure build up significantly.

For fun watch the sequence of events your family goes through when you park the motorhome and ignite the water heater. More than likely someone will run water and relieve the pressure without even realizing it.

HIGH VOLUME ROOF VENT (OPTIONAL)

Manufacturer: FAN-TASTIC VENT CORP.
4349 S. Dort Hwy.
Burton, MI 48529
1-313-742-0330 or 1-800-521-0298

The optional high-volume roof vent system is designed to quickly exhaust stale, hot air and draw in fresh air. It's great to use when the outside temperature really doesn't call for air conditioning, but heat has built up in your coach.

OPERATING INSTRUCTIONS:

1. Rotate 3 speed switch to desired position, 0-off, 1, 2, and 3. The 3 speed switch must be set at 1, 2 or 3 to activate appliance.
2. Rotate thermostat knob toward 40° (cooler) until dome begins operating.
3. When equipped with reverse switch, there is a neutral (off) position. Fan motor will not operate when in/out switch is in its center "off" position. The dome will, however, operate up and down automatically as long as the 3 speed switch remains on.
4. To determine desired temperature setting;
 - a. Use the wall thermometer on furnace thermostat, or any interior temperature indicator.
 - b. Operate fan until interior comfort level is achieved. Rotate thermostat knob toward 110° symbol on label until dome begins closing. You now have the location for normal setting.

The thermostat sensor is calibrated approximately 4°. The minimizes rapid recycling of the unit, once desired temperature level is achieved.

5. The rain sensor built into your fan will prevent excessive rain from entering coach through open dome. Maintain a setting above (to the right of) "rain override" zone and dome will close when sensor becomes wet.

WARNING: Do not leave coach unattended with thermostat knob set in the "rain override" zone.

6. A rain sensor override is built into this system so you can operate your fan during light to moderate rains. When sensor is wet, rotate fan thermostat knob to coolest position to override sensor. Dome will open and fan motor will start. When sensor has completely dried, rotate thermostat knob back to desired setting for automatic operation.
7. To close dome in extremely hot conditions, rotate thermostat knob right, past 110° symbol to off. Dome will come down.
8. Always allow dome to completely cycle up and down. If dome "hangs up" in partially open/close position, rotate thermostat knob to extreme right and then left position allowing complete cycles down and up. Now reset to original comfort level.
9. When vehicle is in storage, rotate thermostat knob to right (off), after dome closes, turn 3 speed switch to "O" (off).

CLEANING INSTRUCTIONS:

- 1) Turn fan motor OFF.
- 2) Remove 8 painted flathead phillips screws around perimeter of screen insert only.
- 3) Clean screen with soap & water solution and reinstall.

SPECIFICATIONS

Airstream constantly strives to improve its product. All specifications are subject to change without notice. Note: all weights and measurements were made on prototype vehicles. Your production motorhome may vary slightly.

DIMENSIONS

39 Ft. W/Slide-out

Exterior Height with Air Conditioner	11' 10"
Interior Head Room	78 1/2"
Interior Width	95"
Exterior Length	39'
Exterior Width	101

CAPACITIES

LPG Tank	181 Lbs.
Fresh Water Tank	105 Gal.
Grey Water Holding Tank	79 Gal.
Black Water Holding Tank	55 Gal.
Fuel Tank, Ford	_____
Fuel Tank, Chevrolet	_____
Fuel Tank, Freightliner	100 Gal. (150 opt.)

CHASSIS COMPONENTS

Trailer hitch	5,000 lb. tow - 500 lb. tongue weight
---------------	---------------------------------------

INDEX

Air Conditioner	I-1	Faucets	G-13
Antenna	H-28	Fabrics, Cleaning	F-1
Appliances	I-1	Filter, Water	G-12
Automotive Fuses	H-2	Floor	F-2
Auxiliary Start Switch	B-4	Furnace	I-2
Auxiliary Battery Switch	H-1	Fuses	H-2
Batteries	H-1, H-24	Gas Lines, LP	G-4
Bed, Rear	F-1	Gas, LP	G-1
Bottled Gas	G-1	Gauges	B-4
By-Pass Valves	G-5, G-18	Generator	D-9, H-32
 		Ground Fault Interrupter	H-32
Cab Seats	B-5	GVWR	B-1
Capacities	J-1	 	
Camping	D-1	Hitch Load	B-5
Carbon Monoxide Alarm	D-4	Humidity	D-8
Carpet	F-2	 	
Caution	Introduction	Interior	F-1
Chairs	F-1	Inverter	H-1
Chassis	C-1	 	
Circuit Breakers	H-2, H-32	Keyless Door Lock	E-2
City Water Hookup	G-11	 	
Cleaning Codes	F-1	Lavatory, Cleaning	F-3
Cleaning, Exterior	E-1	Leveling	D-7
Condensation	D-8	Leveling Jacks	D-7
Converter	H-1	Lights, Interior	H-2
Counter Areas	F-3	Loading	B-1
Curtains	F-2	Locks	E-2
 		Lounge	F-1
Dash Air Conditioner	C-4	LPG System	G-1
Dash Instruments	B-4	LP Leak Detector	D-6
Dimensions	J-1	 	
Dinette	F-1	Maintenance Schedule	A-7
Door Lock	B-4, E-2	Microwave Oven	I-4
Drain Hose	G-21	Monitor Panel	G-19, H-24
Drain Lines	G-18	Mirrors, Remote Control	B-4
Drain Valves	G-19	 	
Drapes	F-2	Overnight Stop	D-7
Drawers	F-3	 	
Driving	B-1	Plastics, Cleaning	F-3
 		Plumbing	G-1
Electrical System	H-1	Power Cord	D-9, H-32
Electric Cord	D-9, H-32	Power Seats	B-5
Electric Step	C-7		
Escape Window	D-1		
Extended Stay	D-9		
Exterior	E-1		

Range/Oven.....	I-4	Upholstery	F-1
Reporting Safety Defects.....	A-6	Ventilation.....	D-8
Refrigerator	I-3	Walls	F-3
Roof Vent.....	I-6	Washing/Waxing	E-1
Roof Storage.....	E-1	Warning	Intro.
Safety Defects, Reporting.....	A-6	Warranty	A-1, A-4
Safety	B-2, D-1, G-2	Warranty Transfer	A-3
Seat Belts	B-3	Warranty Exclusions.....	A-4
Service	A-5	Water Filter	G-12
Sewer Hose.....	D-9, G-19	Water Heater.....	I-5
Shades.....	F-2	Water Hookup.....	G-11
Shower Stall	F-3	Water Pump	G-6
Sinks	F-3	Water System	G-5
Slide-out.....	D-9	Water Tank Fill	G-5
Smoke Alarm.....	D-1	Winterizing	G-17
Sofa.....	F-1	Winter Traveling.....	D-7
Solar Power.....	H-31	Wiring, 12 Volt.....	H-3
Specifications	J-1	Wiring Diagrams, 12 Volt.....	H-4
Step, Electric.....	C-7	Wiring, 110 Volt.....	H-32
Step Well Cover	C-16	Wiring Diagram, 110 Volt.....	H-36
Table.....	F-1		
Tank Capacities	J-1		
Tank Drain	D-7, G-20		
Tank, Sewage.....	G-20		
Tank, Water	G-5		
Tank, LPG.....	G-1		
Tires, Pressure.....	A-7		
Tires, Support.....	C-2		
Toilet.....	G-21		
Towing	B-5		
TV Antenna	H-28		