

OWNER'S MANUAL

**SAFARI**

*By Airstream*



## SAFARI

The Owner's Manual for your new Airstream trailer is designed to respond to the most frequent inquiries regarding the operation, function and care of the many systems that make modern trailering a joy.

### INTRODUCTION

*This manual has been provided by Airstream, Inc. solely for the purpose of providing instructions about the operation and maintenance of its recreational vehicles. Nothing in this manual creates any warranty, either express or implied. The only warranty offered by Airstream, Inc. is set forth in the LIMITED WARRANTY applicable to your vehicle.*

*The LIMITED WARRANTY and the limited warranties issued by component manufacturers require periodic service and maintenance, and the owner's failure to provide this service and/or maintenance may result in the loss of warranty coverage for that item. The owner should review Airstream, Inc.'s LIMITED WARRANTY and the LIMITED WARRANTY of all other manufacturers.*

*Instructions included in this manual are for operating some components which may be optional on your vehicle.*

THE DESCRIPTIONS AND SPECIFICATIONS WERE IN EFFECT AT THE TIME THE MANUAL WAS APPROVED FOR PRINTING.

# AIRSTREAM, INC.

P. O. Box 629  
419 West Pike Street  
Jackson Center, OH 45334-0629

© Airstream, Inc. 1999

## TABLE OF CONTENTS

Introduction _____	Page 1
Responsibilities _____	Page 3
Warranty Explanation _____	Page 4
Reporting Safety Defects _____	Page 7
Weight Rating _____	Page 8
Towing _____	Page 10
Camping and Safety _____	Page 17
Care & Maintenance _____	Page 25
Utility Systems _____	Page 33
Appliances & Equipment _____	Page 65
Specifications _____	Page 73

## **OWNER'S RESPONSIBILITY**

As the owner of a new recreational vehicle, it is important to regularly and properly maintain your vehicle. Be sure to read the Owner's Manual and all appliance manuals so proper maintenance can be applied.

**It is your responsibility to return your vehicle to an authorized dealer for any repairs and service that may be required.**

## **DEALER'S RESPONSIBILITY**

Throughout the manufacturing process, your recreational vehicle has been inspected by our qualified inspectors. However, our final inspection at the factory is not to be the last one. The dealer is to perform a final inspection of your vehicle. And to help you, the owner, fill out and complete all necessary forms and understand the limited warranty pertaining to your new vehicle.

Dealer's responsibilities also include:

1. Familiarizing the customer with the operation of all systems and components of the new recreational vehicle.
2. Explaining and reviewing the LIMITED WARRANTY provisions to the customer.
3. Assisting the customer in completing all necessary registrations and warranty cards for the vehicle.
4. Instructing the customer on how to receive local and out of town service on the vehicle and its separately warranted components.

## **EXPLANATION OF AIRSTREAM LIMITED WARRANTY**

The Airstream Limited Warranty is detailed in a separate folder. A plastic WARRANTY IDENTIFICATION CARD is sent to you after Airstream receives notification from your dealer of the sale. Since this I.D. card is necessary to obtain warranty, it should be kept in the trailer or on your person during the warranty period.

### **EXCLUSIONS:**

#### **Normal Wear**

Items such as tires, water purifier packs, curtains, upholstery, floor coverings, window, door and vent seals will show wear or may even wear out within the one year warranty period depending upon the amount of usage, weather, and atmospheric conditions.

#### **Accident**

We strongly urge our dealers and customers to inspect the trailer upon receipt of delivery for any damage caused by accident while being delivered to the dealer, or while it is on the dealer's lot. Damage of this nature becomes the dealer's or customer's responsibility upon acceptance of delivery, unless Airstream is notified and the damage is verified by the person making the delivery. Glass breakage, whether obviously struck or mysterious, is always accidental and covered by most insurance policies.

#### **Abuse**

Lack of customer care and/or improper maintenance will result in early failure for which Airstream cannot be held responsible.

#### **Exposure**

Not unlike a car, the steel parts of a trailer can and will rust if subjected to prolonged exposure to moisture, salt air, or corrosive air-borne pollutants without repainting. Aluminum oxidizes when unprotected under similar conditions, and refinery chemicals of a sulfurous nature are harmful to finishes if not washed off periodically. Extremely hot or direct sunlight will deteriorate rubber and fade curtains and upholstery. Conditions of this nature, although they may be normal for the area, are beyond Airstream's control and become the responsibility of the owner.

Although it is our obligation to correct a rain or plumbing leak within the terms of the limited warranty, it is the owner's responsibility to use reasonable, prudent care to minimize foreseeable secondary damage, such as a delaminated floor, stained upholstery, carpeting, drapes etc.

## **Overload**

Damage due to loading, either beyond capacity or to cause improper towing because of improper balance, is beyond Airstream's responsibility. The Airstream trailer is engineered to properly handle the gross vehicle load rating on the certification label. Load distribution has a definite effect upon the towing characteristics and attitudes of the trailer. Level hitch installations are a necessity, and very important on a tandem axle trailer. There are limits to the amount of load that can be safely transported depending upon speed and road conditions, and reasonable cause to believe these factors have been exceeded could void the Airstream warranty. For additional information on the loading of your trailer, consult your Owner's Manual or gross vehicle weight rating plate.

The Airstream axle is manufactured to a tolerance of 1° camber and 1/8" tow-in. These tolerances will only change if the trailer is subjected to abuse, such as dropping off a sharp berm, striking a curb, or hitting a deep hole in the road. Such damage could be considered as resulting from an accident which risks are not covered under the warranty. Abnormal tire wear and/or wheel alignment resulting from such damage is not covered under the terms of the warranty.

## **SERVICE:**

The Airstream Silver Key Delivery Program is an exclusive Airstream program. Before leaving the factory, each and every vital part of the trailer is tested for performance. Each test is signed and certified by an inspector. After the trailer arrives on your dealer's lot all of these vital parts and systems are again tested. When you take delivery of your new trailer you will receive a complete check out.

Silver Key Delivery does not stop here. At that time a specified list of performance checks on your trailer equipment will be conducted and any deficiencies you have experienced since taking delivery will be corrected.

Please contact your dealer if you need service. Major service under your Airstream Limited Warranty is available through our nationwide network of Airstream Dealer Service Centers. An up-to-date list of Dealer Service Centers has been provided with your new trailer. This list is current as of the date of publication.

Occasionally dealerships change, or new dealers are added who may not appear on this list. For this reason, it is suggested that you contact your local dealer from time to time and bring your list up to date. He can also provide you with additional copies if you need them. **ALL CENTERS OPERATE ON AN APPOINTMENT BASIS FOR THE UTMOST EFFICIENCY.**

When you require service from the Airstream Factory Service Center, or a Certified Dealer Service Center, please contact the service manager for an appointment, and kindly inform him if you are unable to keep the appointment date or wish to change it.

Service may be arranged at the Factory Service Center by contacting the Service Coordinator at:

**Airstream Factory Service Center  
419 W. Pike Street  
Jackson Center, Ohio 45334  
937-596-6111**

## **INSPECTION**

To assist you in avoiding problems with your vehicle, we recommend you do the following:

- (a) Read the warranty. Go over it with your dealer.
- (b) Inspect the vehicle. Do not accept delivery of the unit until you have gone through the unit with the dealer. He has been provided a checklist. Check each item on the list and make sure he does the same. Do not sign the checklist until you have done this.
- (c) Ask questions about anything that you do not understand concerning your recreational vehicle.

## **OWNER REGISTRATION**

You should fill out and mail the warranty registration within thirty (30) days from the date of delivery.



## **REPORTING SAFETY DEFECTS**

If you believe that your vehicle has a defect which could cause a crash or could cause injury or death, you should immediately inform the National Highway Traffic Safety Administration (NHTSA) in addition to notifying Airstream, Inc.

If NHTSA received similar complaints, it may open an investigation, and if it finds that a safety defect exists in a group of vehicles, it may order a recall and remedy campaign. However, NHTSA cannot become involved in individual problems between you, your dealer, or Airstream, Inc.

To contact NHTSA you may either call the Auto Safety Hotline toll-free at 1-800-424-9393 (or 366-0123 in Washington, D.C. area) or write to: NHTSA, U.S. Department of Transportation, Washington, D.C. 20590. You can also obtain other information about motor vehicle safety from the Hotline.

## WEIGHT RATING

On the inside of the first wardrobe door back on the curbside of your trailer is a weight chart for your particular trailer as it left the factory. If you or your dealer adds other items to your trailer, you will have to take this added weight into consideration.

Below is a facsimile of the weight chart.

<b>TRAILER</b>	<b>CONSULT OWNER'S MANUAL FOR SPECIFIC WEIGHING</b>	
<b>WEIGHT INFORMATION:</b>	<b>INSTRUCTIONS AND TOWING GUIDELINES.</b>	
<b>MODEL</b>		<b>GVWR</b>
<b>UVW</b>	<b>NCC</b>	

**THIS TRAILER IS CAPABLE OF CARRYING UP TO** \_\_\_\_\_ **GAL.**  
**OF FRESH WATER (INCLUDING WATER HEATER) FOR A TOTAL OF** \_\_\_\_\_ **LBS.**  
**REFERENCE: WEIGHT OF FRESH WATER IS 8.33 LBS/GAL; WEIGHT OF LP GAS**  
**IS 4.5 LBS/GAL (AVERAGE).**

**GVWR** GROSS VEHICLE WEIGHT RATING MEANS THE MAXIMUM PERMISSIBLE WEIGHT OF THIS TRAILER. THE GVWR IS EQUAL TO OR GREATER THAN THE SUM OF THE UNLOADED VEHICLE WEIGHT PLUS THE NET CARRYING CAPACITY.

**UVW** UNLOADED VEHICLE WEIGHT MEANS THE WEIGHT OF THIS TRAILER AS BUILT AT THE FACTORY. IF APPLICABLE, IT INCLUDES FULL GENERATOR FUEL, ENGINE OIL, AND COOLANTS. THE UVW DOES NOT INCLUDE CARGO, FRESH WATER, LP GAS, OR DEALER INSTALLED ACCESSORIES.

**NCC** NET CARRYING CAPACITY MEANS THE MAXIMUM WEIGHT OF ALL PERSONAL BELONGINGS, FOOD, FRESH WATER, LP GAS, TOOLS, DEALER INSTALLED ACCESSORIES, ETC., THAT CAN BE CARRIED BY THIS TRAILER.  
 (NCC IS EQUAL TO OR LESS THAN GVWR MINUS UVW).

## LOADING

There are two important factors to keep in mind when loading your trailer. Total weight and balance.

When loading heavy objects such as tools, skillets, irons, boxes of canned goods, etc. keep them as low as possible - preferably on the floor. Try to hold additional weight behind the axle to a minimum.

After loading, the weight of your trailer can only be determined by weighing scales as shown below. Scales capable of weighing your trailer may be found at grain elevators, stone quarries or at a state operated truck scales along the highway. If you are not sure of the location of scales in your area, contact your local state highway patrol post for assistance.

**WARNING:** Never add items such as generators, heavy tool boxes or motorcycle racks to the back of the trailer. Weight behind the axle will tend to magnify any sway that may occur when passing trucks or in gusty wind. If a heavy generator is mounted on the rear bumper, what may have been an almost unnoticeable sway turns into a severe sway you may not be able to control.

**CAUTION:** Damage to your trailer caused by mounting heavy objects on the rear is considered abuse, and is not covered by warranty.

### WEIGHING YOUR TRAILER

The diagram below shows how to weigh the trailer on scales.

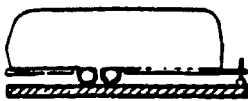

1. Trailer's Total Weight  
(Cannot exceed GVWR)



2. Trailer's Weight on  
Axle Assemblies  
(Cannot exceed GAWR)

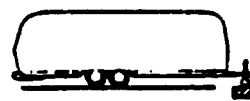

3. Weight on Trailer's  
Tongue.

## TOWING

### HITCHING - TRAILER

Hooking up your trailer will become quite simple to you after a little practice and following these step by step instructions.

1. Crank up the tongue of the trailer until the hitch coupler is high enough to clear the hitch ball on your tow vehicle.
2. Back the tow vehicle to the trailer until the hitch ball is directly under the coupler on the trailer. This is the part that will take a little practice and, if possible, ask another person to help guide you. Another good aid is a mirror that is sold by trailer supply dealers. It attaches to the trailer tongue magnetically and allows you to see the hitch coupler and ball from the driver's seat. When the ball is under the coupler, set the parking brakes, raise the locking latch on the coupler and crank it down onto the ball. Then move the locking latch down to lock it on the ball.

**NOTE:** To release the coupler lock you must first slide the latch forward before it can be raised.

3. Engage the lock and retainer clip.
4. Raise the tongue by cranking the jack down. (The tow vehicle will come up with it if the high coupler is properly latched.) It also makes it easier to install the equalizing hitch bars. Adjust the equalizer bars to the trailer and tow vehicles are level. (See equalizer hitch manufacturer's instructions.)
5. Connect the power cord between the tow vehicle and your trailer.
6. Hook-up the breakaway switch. Be sure that the breakaway switch cable is not attached to any part of the removable ball mount on the vehicle.
7. Crank the jack all the way up.
8. Install and adjust your mirrors.
9. Check all lights on your trailer and tow vehicle - running lights, stop and tail lights, turn signals.
10. Pull the trailer forward and apply the hand control for trailer brakes to be sure they are operating properly.
11. Check inside of trailer and see that everything is stored away, vents closed, all doors and drawers closed, entrance door locked and steps retracted.

## **LOADING INSTRUCTIONS**

Whether you start out for a weekend jaunt or a longer trip, the first thing you are going to do is load such items as food, clothing, bedding, and recreational equipment. As you become experienced in travel trailer living, you will learn what is necessary and what merely takes up storage space.

### **CAUTION**

IT IS ESSENTIAL THAT YOU STORE THE HEAVIER ITEMS CENTRALLY AND AS LOW TO THE FLOOR AS POSSIBLE. SECURE LOOSE ITEMS TO PREVENT SHIFTING. ALWAYS TRY TO EITHER MAINTAIN THE BALANCE OR INCREASE THE WEIGHT TOWARDS THE FRONT.

## **TRAVELING**

### **TOWING**

A good way to practice backing is to choose a large parking lot (where it is permissible) when local business is slow. Don't forget to have your spouse or traveling companion practice guiding you when backing.

Easing to a stop and starting smoothly saves wear and tear on your tow vehicle, saves gas, and prevents damage to the hitch and items stowed in the trailer. Your trailer is designed to be towable at any speed that is safe and smooth for your tow vehicle alone. Remember, when towing the trailer, always maintain a space between you and the car in front of you of at least a car and a trailer length for every 10 miles of speed, giving you ample time to stop in an emergency.

Try to drive with an anticipation of problems that may occur way ahead and prepare for them, even though they may never happen. Anticipate dips, gutters, and depressions in the street, slowing down well in advance, as these are the hardest jolts of any kind on your car, your hitch, your trailer, and items stowed in your trailer. Take dips and bumps slowly and be certain that the trailer wheels have passed the point before accelerating. Cross railroad tracks slowly. Always release your brakes before crossing.

On long grades, shift into a lower gear (or lower range, if you have automatic transmission) before your engine labors.

### **CAUTION**

UNDER NO CIRCUMSTANCES SHOULD THE ENGINE BE ALLOWED TO "LUG" OR PULL HARD FOR EXTENDED PERIODS OF TIME.

When going downhill, use the same procedure as going uphill well in advance, and thus the compression of your car's engine will help to slow your whole rig safely. Avoid conditions that require excessive and prolonged use of your brakes. Apply and release brakes at short intervals to give them a chance to cool.

### **WARNING**

WHEN BEING OVERTAKEN, PASSING OR MEETING AN ONCOMING BUS, TRUCK OR OTHER LARGE VEHICLE, AIR TURBULENCE MAY BE ENCOUNTERED AND MAY CAUSE YOU TO FEEL THE TRAILER SWAY. WHEN THIS OCCURS A SLIGHT ACCELERATION AND/OR LIGHTLY APPLYING THE TRAILER BRAKES ONLY WILL HELP OVERCOME THE SWAY SENSATION: HOWEVER, APPLICATION OF THE TOW VEHICLE BRAKES AT THE BEGINNING OF THE SWAY SITUATION WILL ACCENTUATE THE SWAY AND MAY CAUSE YOU TO LOSE CONTROL OF YOUR VEHICLE.

### **STARTING OUT**

Starting the car slowly, check the traffic after signalling and be sure the road is clear. You are ready to pull into traffic. Accelerate slowly and evenly. Check the mirror frequently to observe the traffic behind you and the action of your trailer. Then move carefully into the proper traffic lane, as you accelerate.

## **TURNING CORNERS**

Here's where you find a first basic difference with a trailer. The trailer wheels do not follow the path of your car's wheels. The trailer will make a closer turn than the car. Compensating for this action when making turns, you will put the car out further into the intersection than you would normally, so that the trailer will clear the curb or clear any parked vehicles along the curb.

Making a left turn requires technique similar to a right turn, with a wider than normal swing into the new lane of traffic to keep the trailer from edging into the opposing lane.

On sharply winding and narrow roads, keep well to the center of your lane, equally away from both the center line and pavement edge. This allows the trailer to clear the edge of the pavement without likelihood of the wheels dropping off onto the shoulder, which could cause dangerous trailer sway. Do not overcrowd or cross the center line. All sharp turns should be taken at low speeds. Professional drivers, when rounding turns, slow down well in advance of the turn, entering it at reduced speed, and then accelerate smoothly as they come out again onto the straightaway.

## **OVERTAKING AND PASSING**

Remember when you pass another vehicle, that it takes longer to accelerate and you must allow for the length of the trailer to pass as well, before returning to your lane. Use your signals freely. On freeways and expressways, try to pick the lane in which you want to move, and stay in it, preferably the slow lane to the right.

You will usually notice that due to your slower speed, cars will be "trapped" behind you on a two-lane road. It is both courteous and practical to signal, pull on the shoulder (when possible) and let them pass. It reduces passing hazards and saves tempers.

## **SLIPPERY PAVEMENT**

On slippery and icy pavement, drive slowly, and if you feel you are skidding, gently apply the trailer brakes only.

## **MUD AND SAND**

Let the momentum of your car and trailer carry you through. Apply power gently and stay in the tracks of the previous vehicle. If you do get stuck, tow the car and trailer out together without unhitching.

## **BACKING AND PARKING**

After arriving at your destination, your next task is to choose a good level parking space and backing into it. A recommended procedure for backing into a space is this:

1. Stop near the site, get out and look it over. (Check the site for low hanging tree limbs, posts, large rocks, etc.)
2. Always try to place the site to your left. This way you can see what the trailer is doing while you are backing. If the site is on your right, you will be backing into your blind side, which is more difficult.
3. With everything clear, maneuver the travel trailer into position for backing into the site.
4. Now grasp the steering wheel at the bottom (never at the top) and back up. Turn the steering wheel in the direction you wish the trailer to go. If the site is on your left, move your hand to the left and back slowly, watching the trailer. When the trailer starts into the turn, follow it by easing up on the steering wheel. The trailer will move into position.



## **SUGGESTED PRE-TRAVEL CHECK LIST**

### **Interior**

1. Turn off water pump switch.
2. Check battery water level.
3. Close windows and vents.
4. Turn off gas.
5. Lock all interior cabinet doors.
6. Latch refrigerator door. (Seal containers first.)
7. Hold down or stack securely all loose, hard and sharp objects.
8. Fasten sliding and foldette doors.
9. Drain toilet bowl.
10. Turn off interior lights.
11. Set table in upright position.
12. Pull up or retract step.
13. Lower blinds.
14. Secure and lock main door.

### **Exterior**

1. Disconnect and stow the electrical hookup cord, the sewer hookup hose (flush out), and the water hookup hose.
2. Turn off gas line shut off valve to appliances.
3. Remove or stow leveling jacks and wheel chocks.
4. Check Hitch: It must be properly attached.
5. Check safety chains and breakaway switch cable.
6. Fully retract jack. Remove and stow jack stand or wood block.
7. Check clearance and stop lights.
8. Check lug nuts.
9. Check tires for correct pressure.
10. Check that TV antenna is properly stowed.
11. Adjust tow vehicle mirrors.
12. Pull forward some 50 ft., test brakes, and check site for forgotten objects and cleanliness.

### **Home**

1. Leave house key with your neighbor.
2. Store valuables and important papers in a safe place.
3. Discontinue newspaper, milk and other deliveries.
4. Ask the Post Office to hold your mail for you.
5. Arrange with the telephone company for discontinued or "vacation service".
6. Arrange care for your pets.
7. Have your lawn, garden and house plants cared for.
8. Lock all windows and doors securely. Keep shades open for a lived in look.
9. Cover all food to keep out mice and insects.
10. Eliminate all fire hazards. Place matches in a tin box or glass jar.
11. Store oil, gasoline and other flammables properly.
12. Destroy all newspapers, magazines and oily rags.
13. Notify police.

## **Trailer Equipment and Accessories**

1. Water hose, 5/8" high pressure, tasteless, odorless, non-toxic.
2. "Y" connection - water hose.
3. Sewer hose with clamp.
4. Drain cap with hose drain.
5. Holding tank cleaner and deodorizer.
6. Power cord adapter 30 amp capacity.
7. 50 ft. electric cord, 12-3 wire.
8. 25 ft. electric cord, 10-3 wire, 30 amp capacity.
9. Wood blocks for leveling.
10. Wheel chocks.
11. Hydraulic jacks.
12. Cross type lug wrench.
13. Quality tire gauge.
14. Emergency road warning triangle.

## **Personal**

1. Automobile insurance to cover you and your family fully.
2. Avoid cash. Use travelers checks and credit cards.
3. Confirm reservations.
4. Have sunglasses for everyone.
5. Pack cameras and films.
6. Make a check list of clothing for everyone, and toilet articles.

## **Motoring Essentials**

1. Display car and trailer registration properly.
2. Carry driver's license. In Canada you will need a non-resident liability insurance card.
3. In Mexico you must have special auto insurance.
4. Carry an extra set of ignition and trunk keys in a separate pocket, or in your wallet.
5. Keep an operating flashlight with fresh batteries in the glove compartment.
6. Pack the trunk so that you can reach the tools and spare tire without completely unpacking.
7. Keep sharp or hard articles securely packed wherever they may be.
8. Do not pack things in the passenger seating area. You need the maximum space for comfort.
9. Wear easy-wash, drip-dry traveling clothes.
10. Do not make your vacation trips a mileage marathon. Stop and relax frequently.
11. Carry a first aid kit.
12. Carry your pet's dish, food, leash and health and registration papers.

## **CAMPING**

### **SET UP**

This section outlines the procedures necessary to stabilize and set up your trailer.

Before attempting to set up the trailer, carefully read and understand these instructions. Setting up your trailer is not difficult but does require some forethought and care.

Your trailer is designed to be efficient and comfortable. Careful attention to details and thoroughness during set up will ensure that you will benefit from all the features and comfort built into your trailer.

During storage or after your trailer has been set up, you may notice slight rippling or waviness of the aluminum sidewall panels if your trailer is sitting in the sun. This is caused by the normal expansion of the materials as they warm up. As the temperature goes down these panels will tend to return to their original shape.

### **LEVELING AND STABILIZATION**

Leveling of your trailer at the site is important. A level trailer is not only necessary for comfort but your refrigerator must be reasonably level in order to operate properly. Stabilization is recommended to keep the trailer from jouncing while unhitched when people are moving inside the trailer.

Stabilizer jacks are intended to stabilize the trailer body while the trailer's full weight is supported by the hitch jack and running gear. Stabilizer jacks are not designed to lift or level the trailer or support its entire weight.

## **Leveling Procedures**

1. If the site is not an asphalt pad, concrete slab or other prepared surface, be sure it is as level as possible. Be sure the ground surface is not soft and will support the weight of the trailer on the stabilizing jacks.
2. Before uncoupling, level the trailer from side to side with suitable lengths of 2" x 6" wood blocks under the trailer wheels. Place the 2" x 6" wood blocks on the ground surface forward of the trailer wheels, and tow the trailer onto the 2" x 6" blocks. Block the trailer wheels so the trailer cannot roll.
3. Put the foot pad on the hitch jack post, uncouple the trailer from the tow vehicle and level the trailer front to rear. It may be necessary to place a sturdy 2" x 6" wood block under the jack post foot pad to support the jack post on soft ground surfaces.

### **WARNING**

**DO NOT ATTEMPT TO LEVEL, RAISE OR OTHERWISE PLACE ALL OF THE WEIGHT OF THE TRAILER ON THE STABILIZER JACKS.**

4. After stabilizing the trailer, be sure the trailer frame is not twisted, buckled, or stressed. Check that all doors and windows operate freely and do not bind.
5. Before resuming travel, be sure all stabilizers are removed or fully retracted.

### **CAUTION**

**THERE ARE SEVERAL WARNING TAGS PLACED ON THE EXTERIOR AND INTERIOR OF YOUR TRAVEL TRAILER. THESE ARE REQUIRED BY LAW. PLEASE FOLLOW THEIR INSTRUCTIONS.**

## **SAFETY**

As always, safety should be one of your top priorities. Make sure you, and everyone traveling with you, can operate the main door and exit window rapidly without light. Contemplate other means of escape in case the designated exits are blocked.

**WARNING:** The rear center window is designed for rapid exit. The 23 foot and 25 foot sleep six have rear corner beds and the escape window has red latches at the bottom. To escape, lift up on the latches and push out. All other models with twin and double beds have the red latches on the sides of the rear window and are turned to release the window so it can be pushed out. The window operation should be checked every trip and the latches and seal lubricated at six month intervals.

**WARNING:** At each campsite make sure you have not parked in such a manner as to block the operation of the escape window by being too close to trees, fences or other impediments. Scenic views are one reason for traveling, but don't park so the beautiful lake or steep cliff is just outside your escape window.

**WARNING:** Read the directions carefully on the fire extinguisher. If there is any doubt on the operation, you and your family should practice, then replace or recharge the extinguisher. You will find your local fire department will be happy to assist you and answer any questions.

**WARNING:** Don't smoke in bed!

**Keep matches out of reach of small children!**

**Don't clean with flammable material!**

**Keep flammable material away from open flame!**

We have all heard these warnings many times; but, they are still among the leading causes of fires.

Other safety information on the LPG system of your trailer is located in the Plumbing Section of this manual.

## **FRESH WATER SUPPLY SYSTEM**

The fresh water system is a demand system. The 12 volt pump will run whenever there is need for water from any faucet. Just turn on the faucet for a smooth continuous flow of water.

A "city" water hook-up with a standard hose connection, is also on your unit to permit connection of your unit directly to a city water supply with a potable water hose. The city water hook-up will bypass the water tank and demand pump. When the city water hook-up is used the switch for the demand pump should be in the off position.

## **WATER PUMP**

The water pump is self priming and totally automatic, operating upon demand when water is required.

1. Fill or partially fill fresh water supply tank.
2. Open kitchen and bathroom faucets.
- \* 3. Turn on switch for water pump and allow it to fill the water lines and water heater.
4. Close each faucet after it delivers steady stream of water.
5. Water pump should stop running after all faucets are closed.
6. Pump should now run when faucet is opened, and stop when faucet is closed.
7. Never allow pump to run for long periods of time without water in supply tank. Damage to pump may result or fuse in circuit line may blow.

When using the demand system and no water comes when a faucet is turned, use this chart to correct the problem.

### **Situation**

Pump running - no water

### **Solution**

1. Fill tank
2. Clear water line to pump

Pump doesn't run

1. Is pump switch on
2. Check 12 volt fuses
3. Check electric connection

All water should be drained from the fresh water system when not in use for more than 1 week.

\*If the water heater is empty, it will take a few minutes to fill.

## **Cleaning the Fresh Water Tank**

To clean the tank pour some bicarbonate of soda into the filler spout with several gallons of water, and allow to stand for a minimum of four hours. Then flush the tank out by opening a faucet, allowing the water pump to drain the system. Then refill with fresh drinking water. If the water tank must be cleaned further, the following procedure is recommended.

1. Prepare a sodium hypochlorite solution using potable water and household bleach (5 1/4 to 6%) in a ratio of 1/4 cup of bleach to one gallon of water. (Common household bleaches are Purex and Chlorox.)
2. Pour 1 gallon of hypochlorite solution for each 15 gallons of capacity into the empty water tank.
3. Add enough potable water to completely fill the water system.
4. Allow closed system to stand for three hours.
5. Drain the hypochlorite solution from the system and refill with potable water. (See Note.)
6. Excessive hypochlorite taste or odor remaining in the water system is removed by rinsing the system with a vinegar solution mixed in a ratio of 1 quart of vinegar to 5 gallons of water.
7. Drain the system and flush with fresh drinking water.
8. Drain the system and refill with fresh drinking water.

Note: A petcock, visible between the tires, will drain the tank sufficiently for most purposes.

## **CITY WATER HOOK-UP**

Simply connect hose to source, open the valve and you have pressurized faucets, toilet and water heater. Open faucets to purge trapped air from water system before lighting water heater.

## **WASTE WATER SYSTEM**

The main parts of the waste water system are the toilet, dual holding tanks, and tank dump valves. The system is designed to provide complete self-contained toilet facilities, while on the road or parked, without being connected to a sewage line. It may also be used in the stationary position while connected to a sewage hose.

Keep the dump valves closed with either method and empty the tanks when they are nearly full. The idea is to send a large volume of water through the tanks and hose at the same time to float solids away.

After the sewage tank has been emptied, close the gate valves and put approximately five gallons of water in the sewage holding tank. This will help prevent solids from building up in the sewage holding tank. The addition of a deodorizing agent like Aqua Kem will help prevent odors.

Should you ever have a build-up of solids, close the valves, fill the tanks about 3/4 full with fresh water, drive a distance to agitate the solids, and drain the tanks.

## **THINGS NOT TO PUT INTO TOILET OR DRAINS**

1. Facial tissues (they do not dissolve like toilet paper).
2. Detergents or bleach. Use a sewage tank deodorizer, available from dealer.
3. Automotive antifreeze, ammonia, alcohols, or acetone.
4. Table scraps or other solids that may clog the drains.

## **POWER SUPPLY CORD**

The power cord is accessible from the outside. Open the cord hatch cover and pull it from the storage compartment. It will reach an outside power receptacle approximately 20 ft. away. If the power receptacle is further than 20 ft. away, use a heavy duty extension cord. Always use an extension cord with a ground lug or third pin.

Many campgrounds provide less than 30 amp service. It is possible to blow their fuse or circuit breaker. If this happens, reduce the load and replace the fuse or reset the breaker.

## **TELEPHONE/CABLE TV**

Located in the power cord storage compartment on the roadside is a receptacle with dual covers. Lifting these covers reveals the receptacles to connect cable TV and telephone lines to your trailer.



## EFFECTS OF PROLONGED OCCUPANCY

Your trailer was designed primarily for recreational use and short term occupancy. If you expect to occupy the trailer for an extended period, be prepared to deal with condensation and the humid conditions that may be encountered. The relatively small volume and tight compact construction of a modern recreational vehicle mean that the normal living activities of even a few occupants will lead to rapid moisture saturation of the air contained in the trailer and the appearance of visible moisture, especially in cold weather.

Just as moisture collects on the outside of a glass of cold water during humid weather, moisture can condense on the inside surfaces of your trailer during use in cold weather when the relative humidity of the interior air is high. This condition is increased because the insulated walls of the trailer are much thinner than house walls. Estimates indicate that a family of four can vaporize up to three gallons of water daily through breathing, cooking, bathing and washing. Unless the water vapor is carried outside by ventilation, or condensed by a dehumidifier, it will condense on the inside of the windows and walls as moisture, or in cold weather as frost or ice. It may also condense out of sight within the walls or the ceiling where it will manifest itself as warped or stained panels. Appearance of these conditions may indicate a serious condensation problem. When you recognize the signs of excessive moisture and condensation in your trailer, you should take action to minimize their effects.

*NOTE: Your trailer is not designed to be used as permanent housing. Use of this product for long term or permanent occupancy may lead to premature deterioration of structure, interior finished, fabrics, carpeting and drapes. Damage or deterioration due to long term occupancy may not be considered normal, and may under the terms of the warranty constitute misuse, abuse, or neglect, and may therefore reduce your warranty protection.*

### Ventilation and Moisture Control

You can reduce interior moisture condensation by taking the following steps:

1. **Ventilate with outside air.** Partially open one or more roof vents and one or more windows to provide circulation of outside air into the interior. While this ventilation may increase furnace heating load during cold weather, it will greatly reduce water condensation. Even when it is raining or snowing, ventilation air from outside will be far drier than interior air and will effectively reduce condensation inside the trailer.
2. **Minimize moisture released inside the trailer.** Run the range vent fan when cooking and the bath vent fan (or open the bath vent) when bathing to carry water vapor out of the trailer. Avoid making steam from excessive boiling or use of hot water. Remove water or snow from shoes before entering to avoid soaking the carpet. Avoid drying overcoats or other clothes inside the trailer.

### WARNING

**DO NOT HEAT THE TRAILER INTERIOR WITH THE RANGE OR OVEN.**

In addition to the hazards of toxic fumes and oxygen depletion, open flames add moisture to the interior air, increasing condensation. Do not use an air humidifier inside the trailer. Water put into the air by the humidifier will greatly increase condensation.

3. **Ventilate closets and cabinets.** During prolonged use in very cold weather, leave cabinet and closet doors partially open to warm and ventilate the interiors of storage compartments built against exterior walls. The air flow will warm the exterior wall surface, reducing or eliminating condensation and minimizing possible ice formation.
4. **Install a dehumidifier.** During prolonged, continuous use, a dehumidifying appliance may be more comfortable and effective in removing excess moisture from the interior air. While use of a dehumidifier is not a "cure-all", and ventilation, storm windows, and moisture reduction continue to be important, operation of the dehumidifier will reduce the amount of outside air needed for ventilation. Heating load on the furnace will be reduced, and the interior will be less drafty.

### **EXHAUST FANS**

The Safari trailers are equipped with roof ventilators either in the center of the ceiling, in the bathroom, or both locations.

The square fans are cranked open and the fan switch turned on to operate. Round ventilators, used in some bathrooms, are opened by pushing straight up on the crossbar handle. The round switch can then be turned to engage the fan motor.

Range hoods have a small knob on top of them to turn on the lights and fan.

**NOTE:** The range exhaust cover on the outside of the trailer has a swinging door that can be latched during inclement weather. During normal operation, the latches should be turned so the door will swing open when the fan is on.

## CARE AND MAINTENANCE

### EXTERIOR

#### Cleaning

As a general rule of thumb, we recommend the trailer be washed about every four weeks and waxed in the spring and fall. To make sure your new unit is always protected you should wax it immediately or have your dealer wax it just prior to delivery. In industrial areas, cleaning and waxing should be done on a more frequent schedule.

ALWAYS CLEAN YOUR TRAILER IN THE SHADE OR ON A CLOUDY DAY WHEN THE ALUMINUM SKIN IS COOL. Oil, grease, dust and dirt may be removed by washing with any mild non-abrasive soap or detergent. Cleaning should be followed by a thorough clean water rinse. Spots and streaks may be prevented by drying the unit with a chamois or a soft cloth. WHEN WASHING OR POLISHING YOUR TRAILER, ALWAYS WIPE "WITH" THE GRAIN OF THE METAL.

**CAUTION: ABRASIVE POLISHES OR CLEANING SOLVENTS SUCH AS AUTOMATIC DISHWASHER OR ACID ETCH CLEANERS ARE TOO STRONG AND SHOULD NEVER BE USED.**

After cleaning and drying, a good grade of non-abrasive automotive paste or liquid wax will increase the life of the finish, especially in coastal areas where the finish is exposed to salt air or in polluted industrial areas. It will also protect the shell from minor scratches and make subsequent cleaning easier.

It is important to remove sap, gum, resin, asphalt, etc. as soon as possible after they appear by washing and rewaxing. Sunlight and time will bake-harden these materials making them almost impossible to remove without heavy buffing. If asphalt remains on the trailer after washing, use a small amount of kerosene on a soft rag and wipe the spots individually, being careful not to scratch the finish.

To keep your trailer looking new, paint the "A" frame, LPG tanks, and rear frame periodically.

It is recommended that the caulking and sealant used in external seams and joints such as end shell segments and around window frames, light bezels, beltline and rub rail molding, etc. be checked regularly. If this material has dried out and become cracked or checked, or if a portion has fallen out, it should be replaced with fresh material to prevent possible rain leaks. Caulking and sealing material is available from your Airstream dealer.

## MAINTENANCE SCHEDULE

**WARNING: FAILURE TO MAINTAIN YOUR COACH CAN CAUSE PREMATURE AND UNEXPECTED PARTS BREAKAGE AND/OR ERRATIC OPERATION THAT MAY BE HAZARDOUS.**

Note: See appliance manufacturer's literature for further information.

### **EVERY 1,000 MILES OR 60 DAYS**

Escape Window	Check operation of latches and upper hinge.
* Battery	Check water level.
Smoke Alarm	Test and replace battery as required.
Tires	Check tire pressure (See Specifications).
Hitch	Check for loose bolts or unusual wear.
GFI Circuit Breaker	Test and record.

**WARNING: On new trailers check lug bolts at 200 miles and 1,000 miles. Torque 85 ft. lbs.**

### **EVERY 5,000 MILES OR 90 DAYS**

Exterior Door Locks	Lubricate with dry graphite.
Exterior Hinges	Lubricate with light household oil.
LPG Hold Down	Lubricate with light household oil.
LPG Regulator	Check bottom vent for obstructions.
Main Door Striker Pocket	Coat with paraffin.
Wheel Lug Bolts	Torque to 85 ft. lbs.
Break Away Switch	Pull pin and lubricate with household oil.
7-Way Plug	Spray with contact cleaner.
Hitch Ball Latch	Lubricate with non-detergent motor oil.
Hitch Ball	Lubricate with hitch ball lube or wheel bearing grease.
Range Exhaust Hood	Clean fan blades and wash filter.
Roof Vent Elevator Screws	Lubricate with light household oil.
Main Door Step	Lubricate moving parts and check.

\* As a battery ages and becomes less efficient, the water level should be checked at more frequent levels.

## EVERY 10,000 MILES OR 6 MONTHS

Brakes	Inspect, adjust or replace as necessary.
Wheel Bearings	Clean and repack.
Tires	Inspect and rotate.
Seals, Windows & Door	Clean with mild detergent and coat with "Slipicone".
TV Antenna	Lubricate all moving parts with silicone lubricant.
Exterior	Wax.
Escape Window	Lubricate latches with WD-40 and clean seals.
Hitch Jack (Manual)	Lubricate with light household oil. (Put oil can spout up under handle).

## EVERY YEAR

Battery	Clean, neutralize and coat terminals with petroleum jelly.
A-Frame, Step	Wire brush and paint A-frame, step, rear frame.
LP Bottles	Have purged by LP supplier.
Seams	Check and reseal exterior seams, window, lights and vents if necessary. Use Kool Seal or equivalent.

## **WHEEL BEARING LUBRICATION**

Your wheel bearings should be repacked every 10,000 miles or every 6 months. Every time the wheel hub is removed, the wheel bearings must be adjusted. Turn the hub slowly to seat the bearings while tightening the spindle nut until the hub will no longer turn. Loosen spindle nut so it may be turned by hand. Tighten nut finger tight then loosen to first hub slot allowing alignment. Install cotter pin.

**NOTE:** Do not move hub during this step.

The spindle nut and hub should be free to move with the cotter pin being the only restraint.

Prepare bearings by cleaning with solvent to remove old grease. Repack by pressing fresh bearing grease into bearing roller area. Repack bearings more often if subject to extremely wet conditions. **If trailer has not been used for more than 2 months, bearings should be inspected and repacked if necessary.**

Repack bearings using a high temperature, automotive type, wheel bearing grease produced by a reputable manufacturer. The soap type should be polyurea, lithium complex or equivalent. Use an NLGI Grade 2 product with a minimum dropping point of 440°F.

## **BRAKE ADJUSTMENT**

The electric brakes are of the drum and two shoe type and adjust the same as most automotive brakes. The adjusting screw is accessible through a hole at the bottom of the backing plate. Remove the hole plug and use a standard brake adjusting tool. Turn the screw until the shoes contact the drum and enough force to make the wheel hard to turn by hand. Then back off the screw six to eight clicks, or until the wheel turns freely.

### **WARNING!**

**IF BRAKE FAILURE OCCURS, HAVE THEM REPAIRED IMMEDIATELY. CONTINUED DRIVING IS DANGEROUS.**

## **TIRES**

Your trailer is equipped at the factory with name brand trailer tires. Airstream dealers cannot make adjustments to tires. This must be done by a dealer who handles that particular brand. If you ever have tire problems, check the local telephone directory for the nearest dealer.

To get the maximum performance from your tires, check the air pressure often, but only when the tires are cool. Never bleed out air immediately after driving. Recommended tire pressures vary with tire type and size. For pressures refer to the SPECIFICATION TABLE.

**WARNING:** It is also important to periodically check on the tightness of lug nuts. They should be tightened to a torque of 85 ft. pounds on aluminum wheels. Care should be taken at all times when handling the forged aluminum wheel because of possible damage to its appearance.

In warm climates, park out of the sun whenever possible. In desert regions use the tire covers to prevent ultra-violet deterioration to tires.

TO CHANGE A TIRE with a jack see the label affixed to the underbelly to the rear of the wheels. This label  points to the plate riveted to the main frame where the jack head must be placed. A flat tire may also be changed without the aid of a jack. Drive the unit up a ramp 8" wide, 6" high and about 3 feet long at the base. Position the good tire on the ramp. This will raise the flat tire clear of the ground.

**WARNING:** Never attempt to change any tire without securely chocking remaining wheels. Never position yourself in a manner where a raised trailer can come down on you if it should become dislodged from a jack or ramp.

All tire and wheel assemblies are balanced at the factory. Be sure to rebalance the tire and wheel assemblies each time a tire is changed or rotated.

In an emergency remove the flat tire. The independent suspension of the Dura-Torque Axle allows four or six wheel units to be safely towed on three or five wheels for a short distance (100 miles maximum) and only at a low speed (30 MPH).

Be especially cautious in crossing holes or dips in the road. Under these circumstances it is good practice to set your rear view mirrors so that you can observe your tires at all time.

## **UPHOLSTERY**

Do not launder upholstery fabrics. Blot up stains promptly, before they set. Use an upholstery cleaner, or mild solvent, depending on the stain. Never soak the fabric. Use as little water as possible. Blot rather than rub. Towel dry or have professionally cleaned.

## **DRAPERIES**

Draperies and upholstery fabrics should always be dry cleaned like any other fine fabric by a competent dry cleaning establishment. Spots and stains should be removed with a commercial spot remover made for this purpose.

## **COUNTERTOPS**

Your countertops are made of high pressure plastic laminates and are highly resistant to normal spills and scuffs. Avoid regular use of abrasive pads and scouring powders which will dull the surface and make it more stain-prone.

Confine knife blades and slicing to a chopping block.

Although the laminate resists heat up to 275 degrees F, pots and pans straight from the oven or burner and irons should be placed on lined hot pads.

## **APPLIANCES**

Refer to the individual manufacturer's owners manuals for care and cleaning for your appliances.

## **CEILINGS**

Clean with a mild detergent in warm water. Never use a strong chemical.

Use a damp cloth to clean ceiling. Excessive moisture may damage the ceiling.



## **INTERIOR FINISH**

The interior surfaces are easy to clean with mild soap and a damp cloth. Waxing is unnecessary. Stubborn stains may be removed with a spray cleaner.

## **FLOOR COVERINGS**

The carpeting in your vehicle is tough and easily maintained. Vacuum regularly to remove abrasive grit. Water based spills and spots should be removed immediately with a damp cloth. Grease or oil based stains and spots should be spot cleaned with a good commercial spot cleaner made for this purpose. If complete shampooing is desired, it is best to have it done by a competent professional carpet cleaner. Never soak or water log your carpeting.

## **TUB AND LAVATORY**

Do not use steel wool, harsh abrasives or liquid cleaners with solvents. These plastic surfaces are best cleaned with soap and water, or dishwashing detergent and water.

## **WINDOWS**

The all-season windows in your travel trailer normally open and close easily. If they become clogged with dirt, clean the mechanism with a small, stiff brush and spray with a silicone lubricant.

## **BEDSPREADS**

The manufacturer of the bedspreads recommends that the bedspreads not be washed, but professionally dry cleaned.

## WINTER STORAGE

1. Level the unit - front to rear and side to side.
  2. Remove bottled and canned goods and other items that could be damaged by freezing.
  - \*3. Open all faucets, valves and drains, including toilet stool valve, water heater drain, and line drain.
  4. Run demand pump till water stops flowing from faucets. Shut pump off immediately. Allow drains, faucets, and valves to remain open for several hours to blow all extra water out with air. Be sure lines are empty.
  5. Close all faucets, valves, and drains.
  6. It is a good idea to use an anti-freeze solution for potable water for more positive protection. Do not use automotive type anti-freeze.
  7. Before using vehicle again, you may want to sanitize the system.
  8. Completely drain holding tanks.
  9. Flush sink, shower-tub, lavatory, and stool with a solution of hot water and dishwasher soap. Allow to drain and flush with clean hot water.
  10. If possible, agitate the water in the holding tanks by driving a few miles, then drain tanks again.
  11. An alternate to step #9 is to use a chemical deodorant. Let mixture stand for a few days, then drain.
  12. Flush with fresh water, drain, and, after tanks are dry, close dump valves and drain cap.
  13. Fill traps with an anti-freeze approved for use in ABS plastic pipes. Normally, a cupful per trap is adequate. Do not use an anti-freeze solution with an alcohol base.
  14. Turn the thermostat off.
  15. Put graphite in all the locks and lubricate all door hinges.
  16. Close all windows and roof vents.
- \* The drain valves for the water tank and hot and cold lines are located on the bottom of the water tank pan and are accessible between the tires. The white valve drains the water tank and the two brass petcocks drain the hot and cold water lines.
- Each trailer has an additional line drain valve above floor. They are accessed:
- 23 foot - through rear trunk door - look to right.
  - 25 foot sleep six - through curbside rear access door - look to left.
  - All others - through roadside rear access door - look to right.
- The water heater drain is accessed on the outside and is a plug or valve in the lower left corner.
- The toilet valve is directly behind the toilet.

## UTILITIES SYSTEMS

### LIQUID PETROLEUM GAS (LPG)

#### FILL VALVE

Your trailer is equipped with LP tank fill valves called "RV Type I Acme" connection. The large, green, nylon swivel nut is a right-hand thread and is designed for hand operation only.

The valve features an internal spring-loaded module that will not allow gas to flow from the cylinder until a positive seal has been made at the connection. The valve outlet has 1-5/16" Acme threads on the outlet exterior and female POL, left-handed threads on its interior. This feature allows for connection of the new wrenchless, right-handed, Acme RV connection and still accommodates the standard left-handed POL fittings used for filling propane cylinders.

The mating, green swivel nut and brass nipple also incorporates new features: the green nylon nut swivels on a black bushing that is heat sensitive. Between 240° F and 300° F the bushing will yield (melt) allowing the spring-loaded module in the valve to push the brass nipple back (approximately 1/4") closing the module and stopping the flow of gas from the cylinder. Inside the brass nipple is a flow-limiting device designed to sense excessive gas flow. If an excessive flow is sensed, the flow-limiting device shuts the flow down to a maximum of 10 SCFH (Standard Cubic Feet per Hour) or less. This is also referred to as the by-pass flow.

By-pass flow is extremely important in the proper operation of this connection. The flow-limiting device may activate if the cylinder valve is opened quickly. When all appliances are off, the by-pass flow allows the pressure downstream from the flow-limiting device to equalize. When pressure is equalized, the flow-limiting device will supply normal flow to the system. Equalization occurs in approximately 5 seconds and in most cases goes completely unnoticed. If, however, an appliance is left on or there is a leak or open flow in the system, the by-pass pressure will not be able to equalize and allow the flow-limiting device to re-open. Symptoms of this condition would be appliances that light but have lower than normal flame or starve out from lack of gas; a substantial reduction in the flame when another appliance is operating; or pilots that are difficult to light. If this should happen, the following steps should eliminate the condition:

1. Close LP cylinder valve.
2. Extinguish all flames and smoking materials.
3. Be sure all gas appliances, including their pilot lights, are off.
4. Open LP cylinder valve slowly. DO NOT SNAP OPEN.
5. Wait at least 15 seconds before lighting appliances.
6. If operational difficulties continue, there may be a leak in the system. Immediately close the LP cylinder valve and have the system inspected by a qualified RV service technician.

Again, make sure all appliances are off before opening propane cylinder valves.  
Exception: when reconnecting a full cylinder to an auto changeover regulator it is not necessary to shut off the appliances or close the valve of the cylinder already in service.

**WARNING: Leaking LP gas may ignite causing a fire or explosion which could result in serious bodily injury, property damage or death!**

How long a full tank of gas will last is dependent on usage. In cold weather, when you are using the furnace, large amounts of hot water, and are doing extensive cooking, you will naturally use more than you will in warm weather when you may do limited cooking. On the average, with normal cooking and other appliance use you can probably count on two to three weeks service from each tank.

### **AUTOMATIC GAS REGULATOR**

All models are equipped with an automatic gas regulator. Both tanks are connected to this regulator. Open both tank valves completely, then close about 1/4 turn. This will allow you to easily check to see if valves are open or closed.

When the gas is turned on it is drawn from only one tank at a time. When the tank being used is depleted the regulator automatically switches to the full tank. An indicator in the regulator knob points toward the tank which is being used to give you a visual reminder when one tank is empty.

**Note:** The tank in use is not completely empty until the red warning flag is fully visible in the indicator window. The empty tank can be removed for refilling without disturbing the tank being used.

**WARNING:** LP gas regulators must always be installed with the diaphragm vent facing downward. Regulators that are not in compartments have been equipped with a protective cover. Make sure that regulator vent faces downward and that cover is kept in place to minimize vent blockage which could result in excessive gas pressure causing fire or explosion.

**CAUTION:** The LPG bottles are securely mounted on the front "A" frame of your trailer. If these bottles must be removed for service or replacement it is important that they be reinstalled correctly in order to prevent any possibility of their falling off or becoming dislodged during travel.

**WARNING:** Your LP tanks must be filled as directed by the tank manufacturer. Instructions are located on a decal near the fill valve. The decal must not be defaced.

**WARNING:** Your LP tank must be placed in the proper position when remounting on the front of the trailer.

**WARNING:** Use only the gas bottles furnished with your trailer. If replacement is required it must be a bottle of the same size and design.

**WARNING:** The vent at the bottom of the regulator must be kept free of any obstructions and must be pointed downward. A good habit is to check the vent each time a bottle is removed for filling. It is especially important to check the vent if the trailer has not been used regularly.

If you have allowed both tanks to run out, air may have gotten into the lines. In this event the air must be forced out through the lines by gas pressure before you will be able to light the pilots. Hold a match to the pilot of the appliance closest to the tanks until it lights and stays lit. Then move to the next closest, etc.

Twice a year, or after a long storage period, we suggest you take your unit in for a checkup and cleaning of the gas operated appliances.

#### **BASIC RULES FOR SAFETY**

**WARNING:** Do not store LP containers within vehicle. LP containers are equipped with safety devices that vent gas should the pressure become excessive.

**WARNING:** Do not use cooking appliances for comfort heating. Cooking appliances need fresh air for safe operation. Before operation open overhead vent or turn on exhaust fan and open window.

A warning label has been located in the cooking area to remind you to provide an adequate supply of fresh air for combustion. Unlike homes, the amount of oxygen supply is limited due to the size of the recreational vehicle; and, proper ventilation when using the cooking appliances will avoid dangers of asphyxiation. It is especially important that cooking appliances not be used for comfort heating as the danger of asphyxiation is greater when the appliance is used for long periods of time.

**WARNING:** Portable fuel burning equipment, including wood and charcoal grills and stoves, shall not be used inside the recreational vehicle. The use of this equipment inside the recreational vehicle may cause fires or asphyxiation.

**WARNING:** A warning label has been located near the LP gas container. This label reads: **DO NOT FILL CONTAINER(S) TO MORE THAN 80 PERCENT OF CAPACITY.**

**Over filling the LP gas container can result in uncontrolled gas flow which can cause fire or explosion. A properly filled container will contain approximately 80 percent of its volume as liquid LP gas.**

**WARNING: Do not bring or store LP gas containers, gasoline or other flammable liquids inside the vehicle because a fire or explosion may result.**

**WARNING: IF YOU SMELL GAS:**

- 1. Extinguish any open flames, pilot lights and all smoking materials.**
- 2. Do not touch electrical switches.**
- 3. Shut off the gas supply at the tank valve(s) or gas supply connection.**
- 4. Open doors and other ventilating openings.**
- 5. Leave the area until odor clears.**
- 6. Have the gas system checked and leakage source corrected before using again.**

## WATER SYSTEM - SELF CONTAINED

Fill the water tank by opening the exterior access door on the curbside of the trailer and remove screw cap. A garden hose can now be inserted. It's a good idea to let the water run through the hose for a short time to flush it out. Experienced RVers usually fill their tanks with "home" water to avoid strange water that may be distasteful to them.

The amount of water in the tank may be checked on the Monitor Panel, or you may fill the tank until water overflows out of the fill.

Turn water heater by-pass valves to normal flow position. Shut-off valve B - open valves A and C. Access to the by-pass valves vary according to model.

Access is:

23 foot - through hole in bed top under mattress.

25 foot sleep six - through curbside rear exterior access door.

All others - through roadside rear exterior access door.

Open the hot side of the galley or lavatory faucet and turn on the water pump switch located on the monitor panel. For some time the open faucet will only sputter. This is because the water heater is being filled and air is being pushed out through the lines. Once the water heater is full a steady stream of water will come from the faucet. Now open a cold faucet. It will sputter for a short time, but will soon expel a steady stream. All other faucets can now be opened until all air is expelled.

Once the system is filled with water and the faucets closed, the water pump will shut off. When a faucet is opened the pump will come back on automatically. If the faucet is just barely open it is normal for the pump to cycle on and off rapidly.

**CAUTION: The water pump must be turned off when hooked up to city water supply and when you leave your Airstream unattended.**

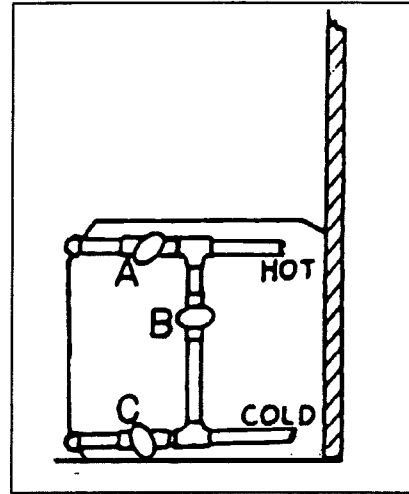

## WATER PUMP AND FILTER

On the **23 foot** model, the water pump is located below the range. The small brown plugs “pop” out revealing screws to remove the access panel.

The **25 foot** models all have a section of the curbside wardrobe floor that lifts up to expose the pump and filter.

The **27 foot** units have a removable toe-kick under the curbside wardrobe for access.

To clean strainer screen first remove inlet connection from pump side of strainer. This will allow the intake side of the strainer to be rotated about 1/8 turn counter clockwise and removed. The screen part of the strainer will now be accessible for cleaning.

When reassembling only rotate the inlet side of the strainer until the stops are felt. Sealing is performed by the “O” ring and too much pressure will only break the strainer.

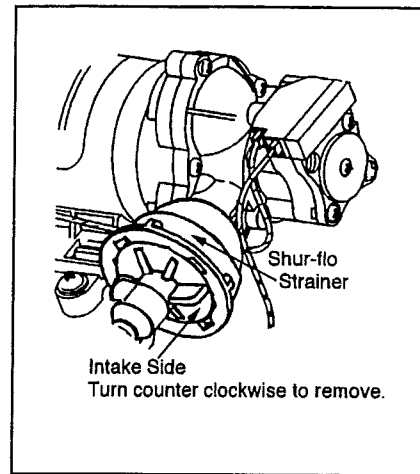

## CITY WATER HOOKUP

The city water hook-up is found on the lower roadside, rear corner of the trailer close to the bumper.

Use a high pressure hose of at least 1/2” diameter. It should be one that is tasteless, odorless and non-toxic designed for RV use. The city water inlet is a standard garden hose thread. We suggest you carry two lengths of hose. This way you have the ability to reach hookups further away than normal, plus you have a spare hose should one fail or become damaged unexpectedly.

After hooking up the hose and turning on the city water valve provided in the park, slowly open a faucet. There will be a lot of spurts and sputtering until all the air is expelled from the trailer system. If the water heater is empty it will take some time before all the air is expelled and you get a steady flow of water at the faucet. Once a steady flow is achieved at one faucet the others should be opened long enough to expel the air in the lines going to them.

During city water operation the water pump switch should be in the off position. A check valve built into the pump protects it from city water pressure.

Your plumbing system has a built in pressure regulator to protect your lines and faucets from extremely high pressures on some city water systems.



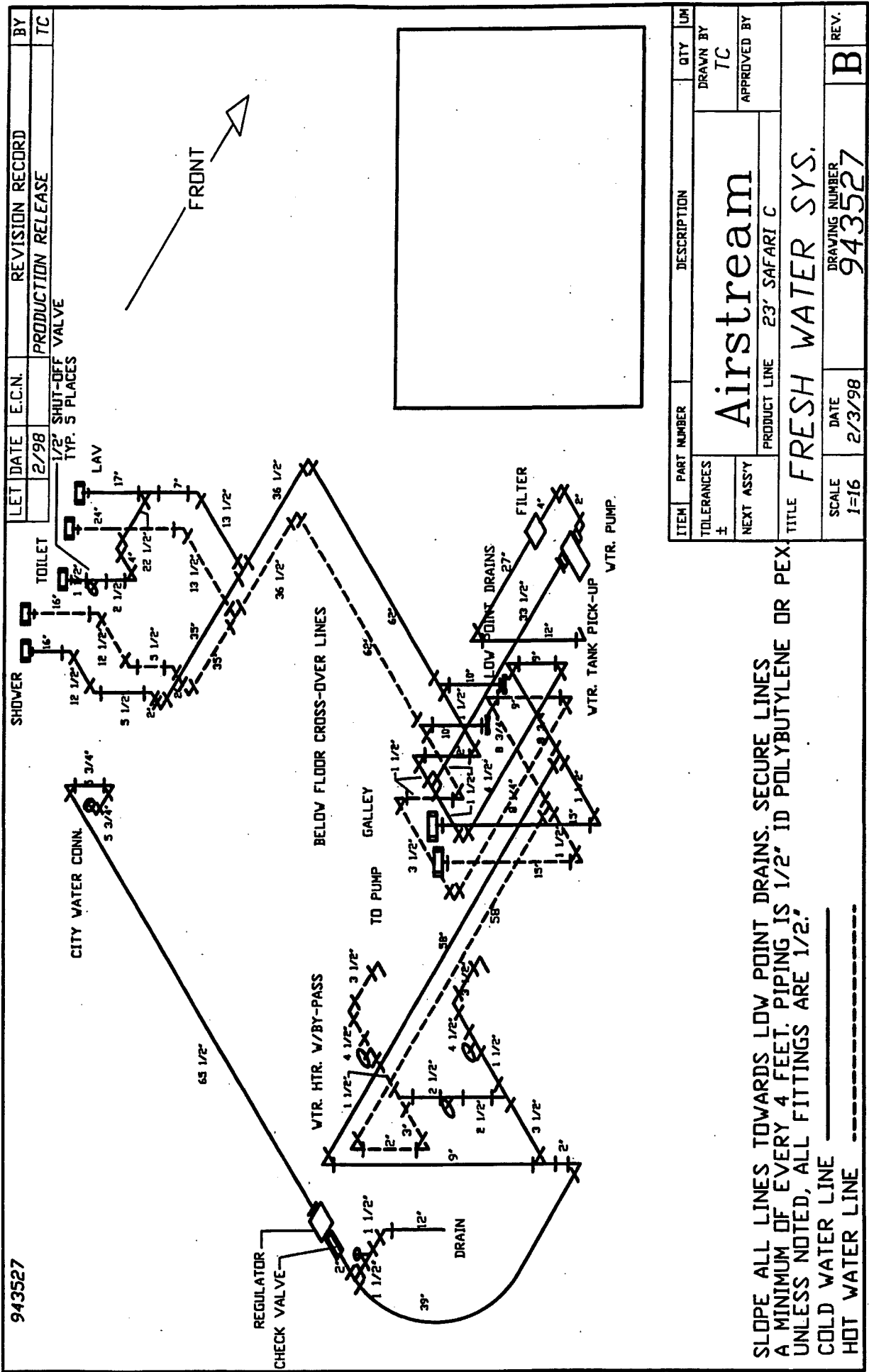

943527	LET DATE	E.C.N.	REVISION RECORD	BY
	2/98		PRODUCTION RELEASE	TC
	1/2" SHUT-OFF VALVE TYP. 5 PLACES			

ITEM	PART NUMBER	DESCRIPTION	QTY	UM
TOLERANCES		<b>Airstream</b>	DRAWN BY	
±			TC	
NEXT ASSY		PRODUCT LINE	APPROVED BY	
		23' SAFARI C		
TITLE				
<b>FRESH WATER SYS.</b>				
SCALE	DATE	DRAWING NUMBER	REV.	
1=16	2/3/98	943527	B	

SLOPE ALL LINES TOWARDS LOW POINT DRAINS. SECURE LINES A MINIMUM OF EVERY 4 FEET. PIPING IS 1/2" ID POLYBUTYLENE OR PEX. UNLESS NOTED, ALL FITTINGS ARE 1/2".

COLD WATER LINE \_\_\_\_\_

HOT WATER LINE -----

LET DATE	E.C.N.	REVISION RECD	BY
3/97		PRODUCTION RELEASE	TC

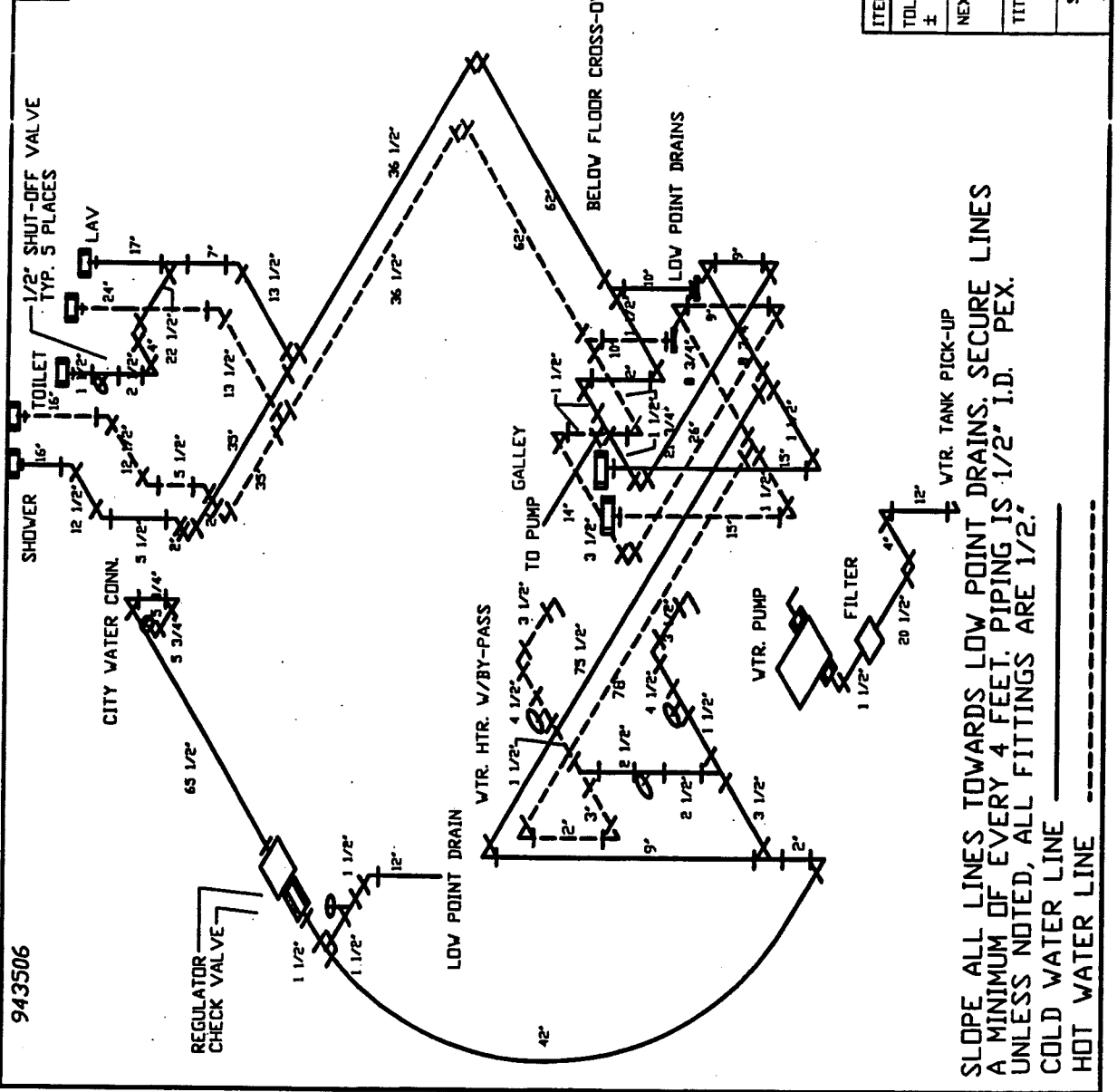

SLOPE ALL LINES TOWARDS LOW POINT DRAINS. SECURE LINES A MINIMUM OF EVERY 4 FEET. PIPING IS 1/2" I.D. PEX. UNLESS NOTED, ALL FITTINGS ARE 1/2".

COLD WATER LINE \_\_\_\_\_

HOT WATER LINE - - - - -

ITEM	PART NUMBER	DESCRIPTION	QTY	UM
TOLERANCES				
±				
NEXT ASSY				
TITLE		Airstream		
SCALE		DRAWING NUMBER		
1=16		943506		
DATE		REV.		
4/19/1997		B		
PRODUCT LINE		25' SAFARI C		
APPROVED BY		TC		

LET DATE	E.C.N.	REVISION RECORD	BY
1/99	4744	PRODUCTION RELEASE	TC

SLOPE ALL LINES TOWARDS LOW POINT DRAINS. SECURE LINES  
 A MINIMUM OF EVERY 4 FEET. PIPING IS 1/2" I.D. PEX.  
 UNLESS NOTED, ALL FITTINGS ARE 1/2".  
 COLD WATER LINE  
 HOT WATER LINE

943522

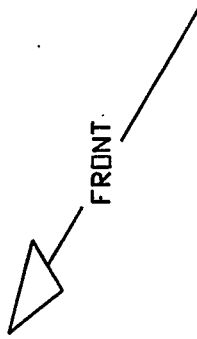
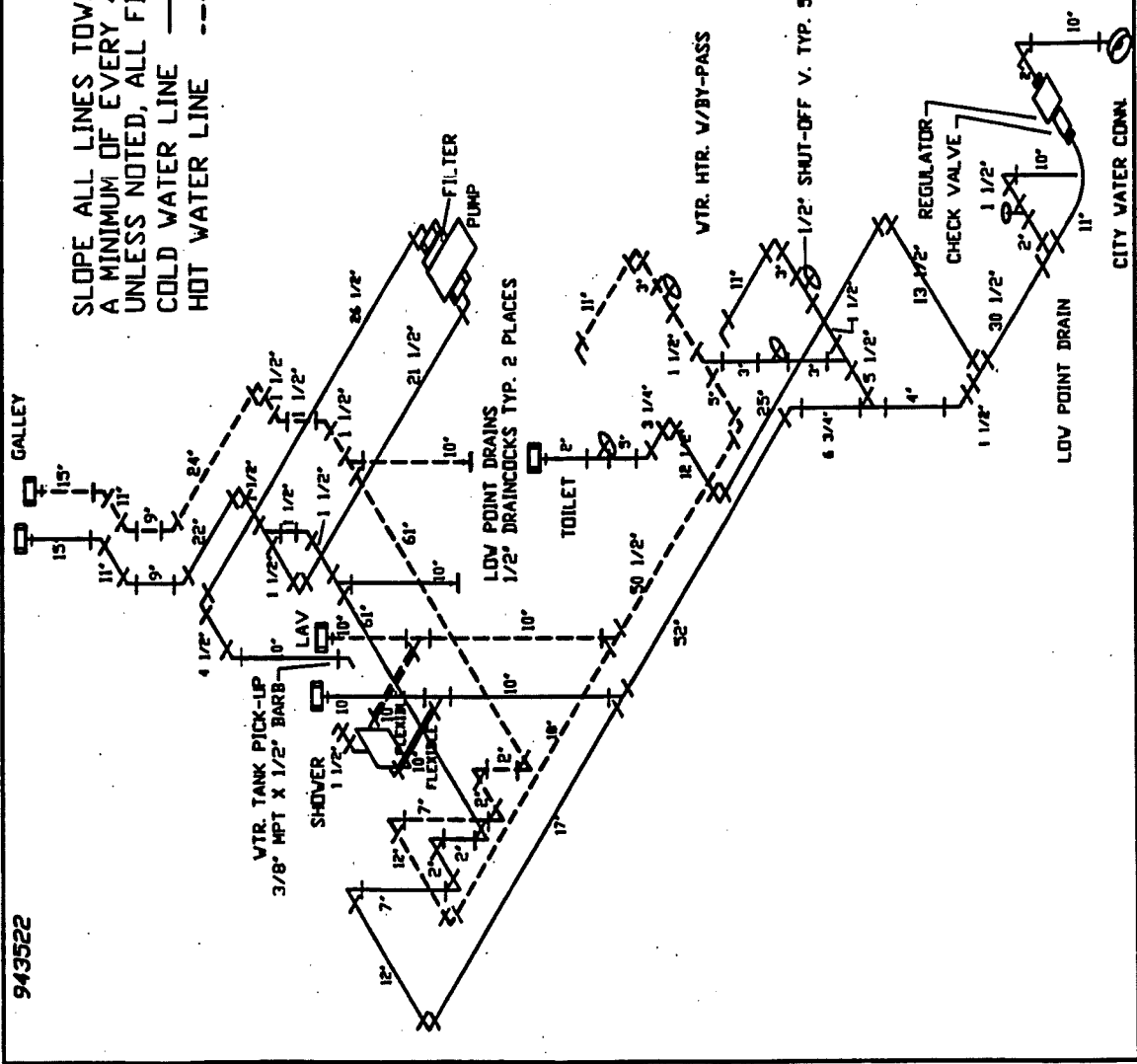

ITEM	PART NUMBER	DESCRIPTION	QTY	UM
TOLERANCES				
±				
NEXT ASSY				
TITLE		Airstream		
PRODUCT LINE		27' SB SAFARI		
TITLE		FRESH WATER SYS.		
SCALE	DATE	DRAWING NUMBER	REV.	
1=16	1/29/99	943522	B	

## **DRAIN VALVES**

The line drain valves have been moved to the exterior of the coach for easier access. If you look between your tires you can see a "box" that is a few inches lower than the trailer frame. This "box" or pan supports the water tank.

The line drains will be the two brass petcocks extending from the bottom of the pan. The white plastic petcock, you will see, is to drain the water tank.

Each trailer has an additional line drain valve above floor. They are accessed:

23 foot - through rear trunk door - look to right.

25 foot sleep six - through curbside rear access door - look to left.

All others - through roadside rear access door - look to right.

## **To Empty Fresh Water Tank**

The fresh water tank may be emptied by pumping the water out with the self-contained water pump. Simply turn on the pump switch and open a couple of faucets until the water will no longer come out. On all models there is also a petcock type drain valve located in the wheel well and extended out through the tank support pan.

## **Water Heater Draining**

All models have a drain plug or petcock on the water heater. Access is from the exterior. The plug or valve is usually located in the lower left corner, viewed as you face the exterior of the water heater.

## **ELECTRICAL SYSTEM**

Your electrical system is a combination 12 volt and 110 volt system, every facet carefully engineered and installed to comply with the "American National Standard #A 119.2" and the "National Electric Code".

The combination system consists of:

1. 12 volt automotive system.
2. 110 volt outside power source.
3. 12 volt trailer system.

### **110 VOLT SYSTEM**

This is supplied by plugging the power cord into an outside 110 volt receptacle. It furnishes current to 110 volt roof air conditioners, refrigerator and all internal 110 volt receptacles. It also supplies power for the 12 volt trailer system through the converter.

The 110 volt circuits are protected by circuit breakers. The most common cause of a circuit breaker to open is an overloaded circuit. If this happens, reduce the load and reset the breaker.

Your bathroom and exterior receptacles are protected by a highly sensitive device known as a "Ground Fault Interrupter", which is designed to sense the slightest electrical "short" at those receptacles and instantly disconnect the current before a person can be injured.

#### **CAUTION**

**NEVER REPLACE CIRCUIT BREAKERS OR FUSES OF HIGHER CURRENT RATING THAN THOSE ORIGINALLY INSTALLED. THIS COULD OVERHEAT THE WIRING AND START A FIRE.**

The 110 volt circuit breaker boxes are behind false panels held in place with velcro.

On corner bed models, the breaker box is located in the bottom of the wardrobe just forward of the lavatory.

Twin bed units have the breaker box under the forward end of the roadside twin bed.

Double beds have the breaker box in the side of the bed facing towards the front.

The velcro holding these panels in place can be very tight. Slow, steady pressure will reward you with a ripping sound as the velcro comes free.

## **12 VOLT INTERIOR**

### **Distribution Panel**

The low voltage distribution panel is located on the interior front panel below the window. The circuits are protected by ATC type fuses common to the automotive industry. Fuses are available at almost all service stations and automotive parts stores.

If you replace a blown fuse and it immediately blows again, do not replace the fuse again until the problem can be corrected by a qualified service technician.

If the replacement fuse holds for a week or more and the gap in the fusible metal is barely melted apart it usually indicates an overload condition. Reducing the number of lights or appliances used on that particular circuit at the same time could prevent any further fuse failure.

Each trailer has a master 12 volt switch often called a "kill switch". Turning this switch off cuts all the connection between the trailer battery and the distribution panel. Your appliances and 12 volt accessories are designed to operate with the battery in the system so the switch should always be "on" when using the trailer. The intent of the switch is for storage or when servicing the trailer. For long term storage the best procedure is to disconnect a battery cable and if in a cold climate remove the battery complete and store in an area where temperatures are not as severe and it can be kept charged.

The master switch is located in the shelf below the front window behind the couch.

## 12 VOLT AUTOMOTIVE SYSTEM

The 12 volt battery in the tow vehicle supplies this current to the trailer's electric brakes, clearance lights, turn signals, tail, stop, back-up lights and charges the trailer battery when the engine is running.

The electrical connector wiring color code is as follows:

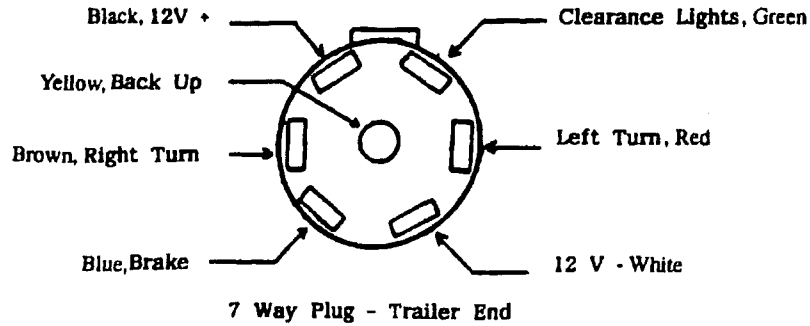

## WIRING DIAGRAMS

On the following pages are the wiring diagrams for the Safari trailer.

### DIAGRAMS:

12 volt distribution panel	-	all models
Chassis and battery	-	all models
Harness, tail and clearance lights	-	all models
Harness, front clearance lights	-	all models
Harness, ceiling	-	23 ft.
Harness, body interior	-	23 ft.
12 volt calculations	-	23 ft.
Harness, ceiling	-	25 ft.
Harness, body interior	-	25 ft.
Harness, body interior	-	25 ft. sleep six
12 volt calculations	-	25 ft.
Harness, ceiling	-	27 ft.
Harness, body interior	-	27 ft.
12 volt calculations	-	27 ft.
110 volt circuit breaker box	-	all models
110 volt wiring	-	23 ft. & 25 ft. C models
110 volt wiring	-	25 ft. sleep six
110 volt wiring	-	27 ft.



952586-01

LET	DATE	E.C.N.	REVISION RECORD	BY
A	9/96		PRODUCTION RELEASE	TC
	11/97		ADD BAMB	TC

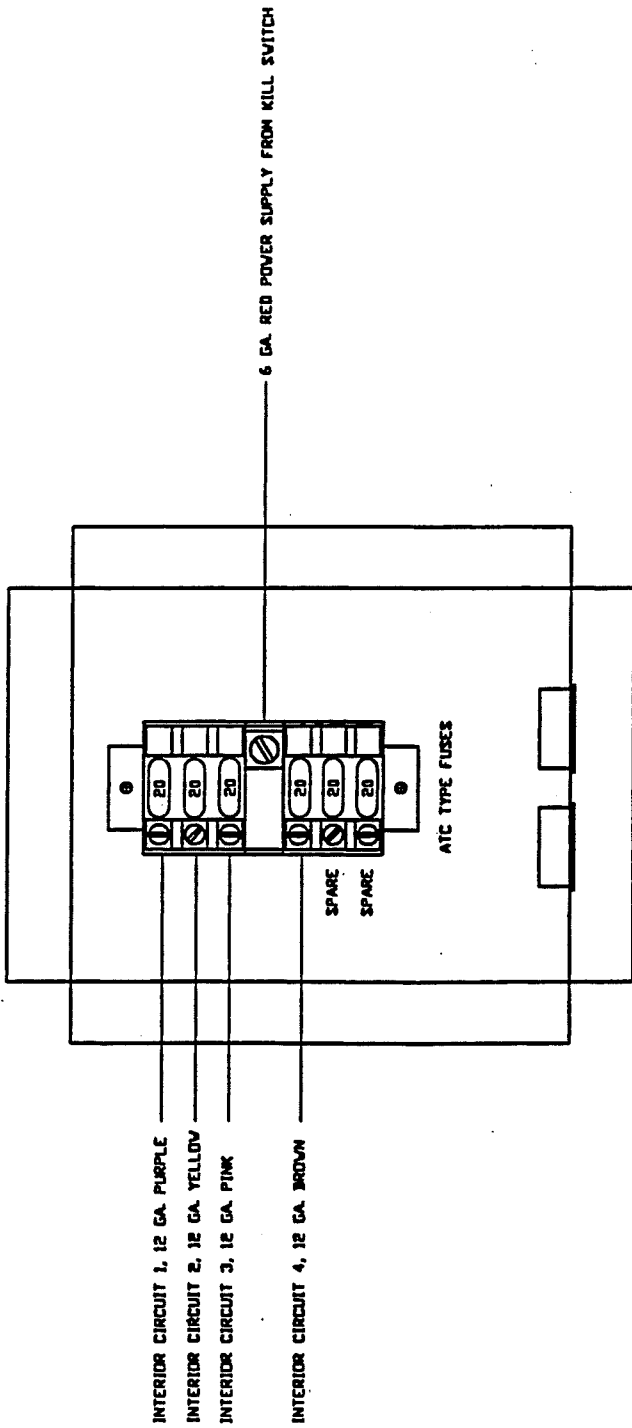

ITEM	PART NUMBER	DESCRIPTION	QTY	LN
		<b>Airstream</b>		DRAWN BY T.C.
		PRODUCT LINE SAFARI & BAMB		APPROVED BY ALL V
TITLE 12 VOLT ELECTRICAL PAGE 1 OF 2				
SCALE 1=2	DATE 9/5/96	DRAWING NUMBER 952586-01	REV. A	A

952586-02

LET	DATE	E.C.N.	REVISION RECORD	BY
A	9/96		Production Release	TC
	11/97		ADD 50A BREAKER, ADD BAMBI	TC

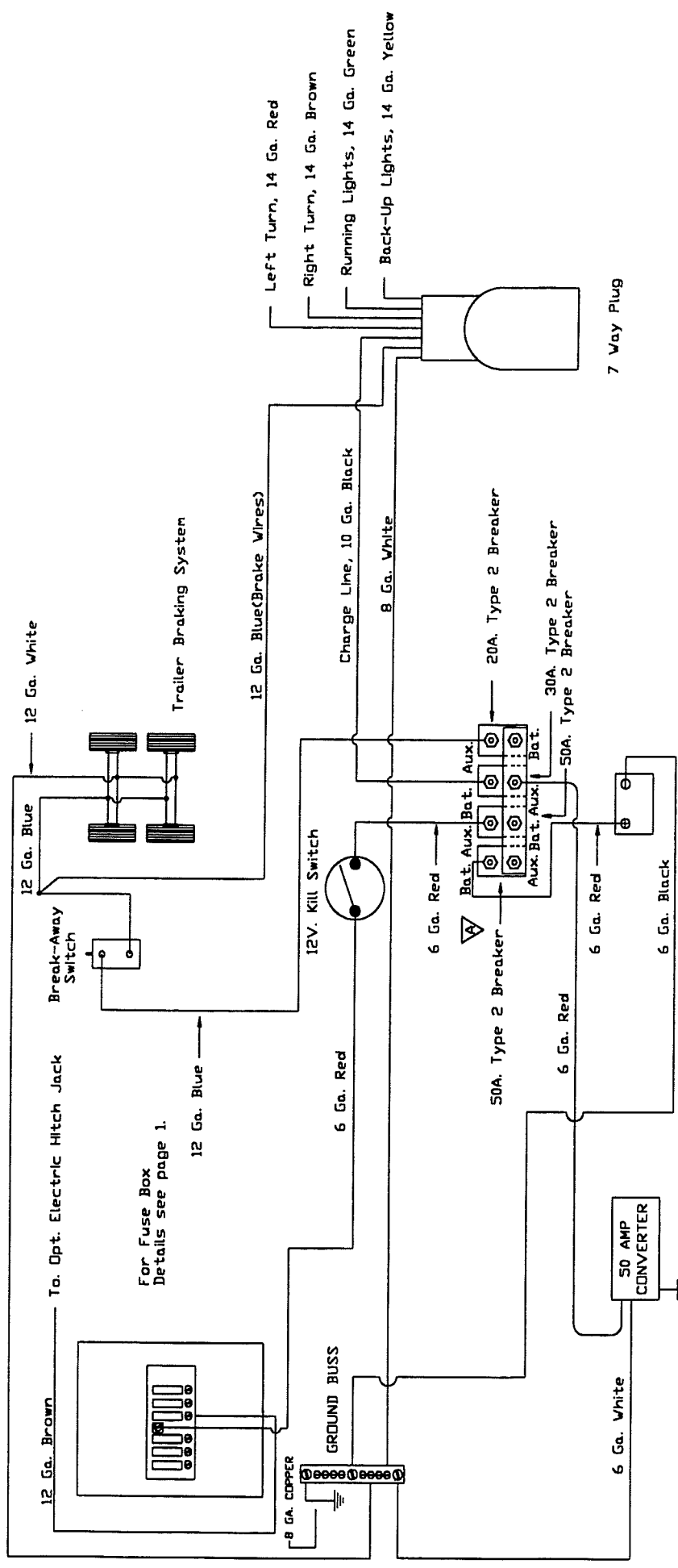

Battery overcurrent protection is within 18 inches of the point of where the power supply connects to the vehicle circuits.

ITEM	PART NUMBER	DESCRIPTION	QTY	UM
TOLERANCES		<h1>Airstream</h1>	DRAWN BY T.C.	
NEXT ASS'Y			APPROVED BY	
TITLE		PRODUCT LINE	SAFARI & BAMBI TRLS.- ALL	
SCALE		DATE	REV.	
1-2		9/5/96	DRAWING NUMBER	
			952586-02	
		12 Volt Electrical Page 2 of 2		A

LET	DATE	E.C.N.	REVISION RECORD	BY
S-90	4265		PRODUCTION RELEASE	J.S.
A	11-90	4282A	55 was 45; 27 was 17; 16 was 12	J.S.
B	4/93	4409H	REV. FOR 1994 A/S TR.	R.A.
C	6/93	4409S	Move Tail Lt. Break-out	R.A.
D	6/95	4509A	Revised For 1996	R.A.
E	6/96	4585C	Added Rear Clearance Lt. B.D's.	RA

No.	Ga.	Color	Cutting Length	Function
16	14	BLACK	148"	BACK-UP LIGHTS
17	14	RED	104"	LFT. TURN & STOP
18	14	GREEN	372"	TAIL CLRNCE L.TS
19	14	BROWN	134"	RT TURN & STOP
20	14	WHITE	390"	GROUND

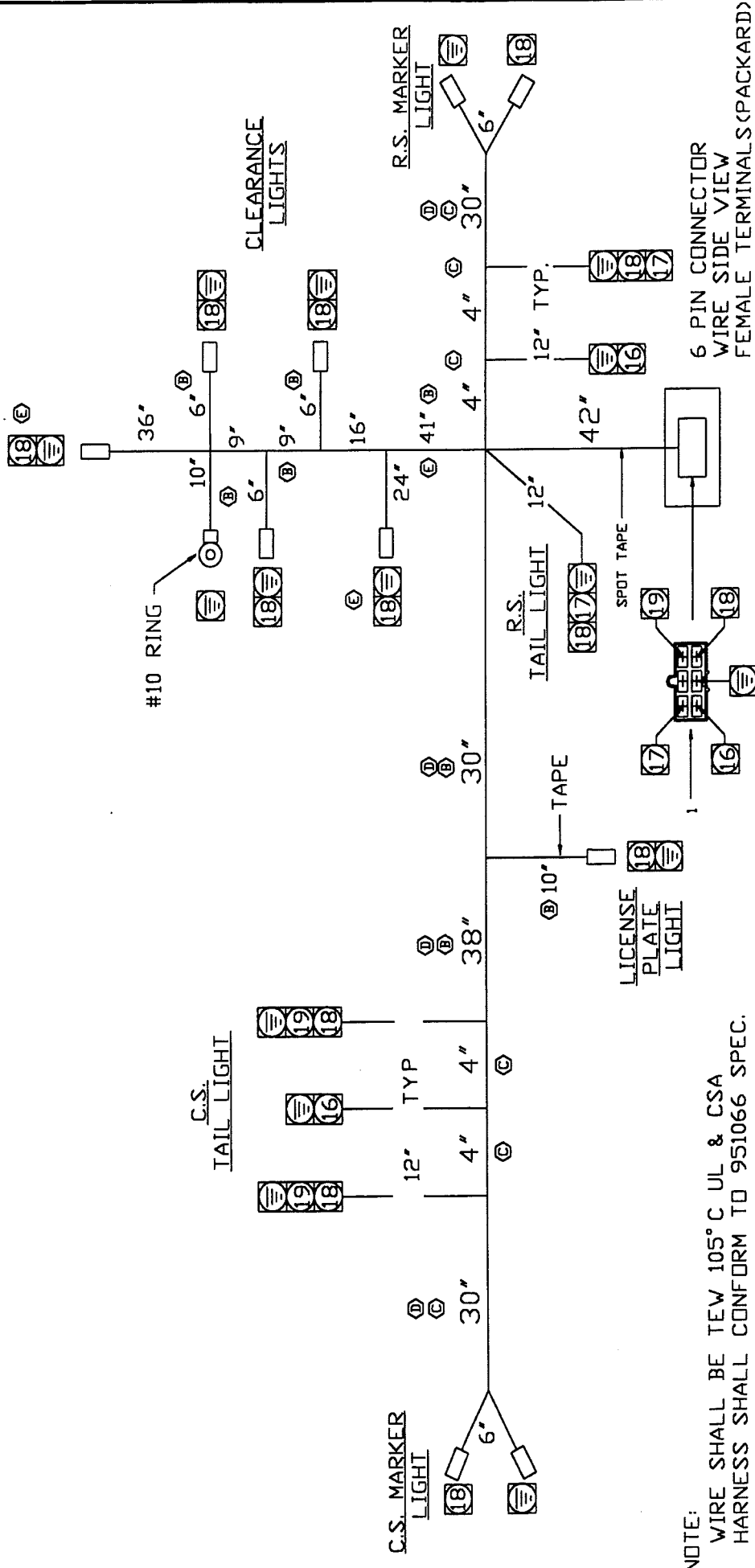

NOTE:  
 WIRE SHALL BE TEW 105° C UL & CSA  
 HARNESS SHALL CONFORM TO 951066 SPEC.

Terminals	
	Bullet .180 Male
	Bullet .180 Female
	Butt Connector
	Ring Miniature
	Spade .250 Female
	Spade .250 Male

- = 20 Ga Wire
- = 18 Ga Wire
- = 16 Ga Wire
- = 14 Ga Wire
- = 12 Ga Wire
- = 10 Ga Wire
- = 8 Ga Wire

2	510834-08	TERMINAL, FEMALE, 2965511	5
1	510837-02	CONNECTOR, 6-WAY, 2977044	1
ITER PART NUMBER		DESCRIPTION	QTY
TOLERANCES			
±1"			
NEXT ASSY			
DRAWN BY		R.L.A.	
APPROVED BY			
Airstream			
PRODUCT LINE 1994 A/S TRAILER			
TITLE HARNESS, TAIL & CLR. LT.			
SCALE	DATE	DRAWING NUMBER	REV.
1=None	05/08/90	510905-05	C E

No.	Ga.	Color	Cutting Length	Function
10	14	GREEN	244"	TAIL & CLR. L.T.S.
11	14	WHITE	256"	GROUND

LET	DATE	E.C.N.	REVISION RECORD	BY
A	5-90	4265	PRODUCTION RELEASE	J.S.
B	11-90	4282A	90 WAS 70; 20 WAS 12	J.S.
C	4/93	4409H	ADDED BUTT CONNECTORS	R.A.
	06/93	4409S	REV. FOR 1994 A.S. TRL.	R.A.
			DELETE 3 BREAKOUTS	R.A.

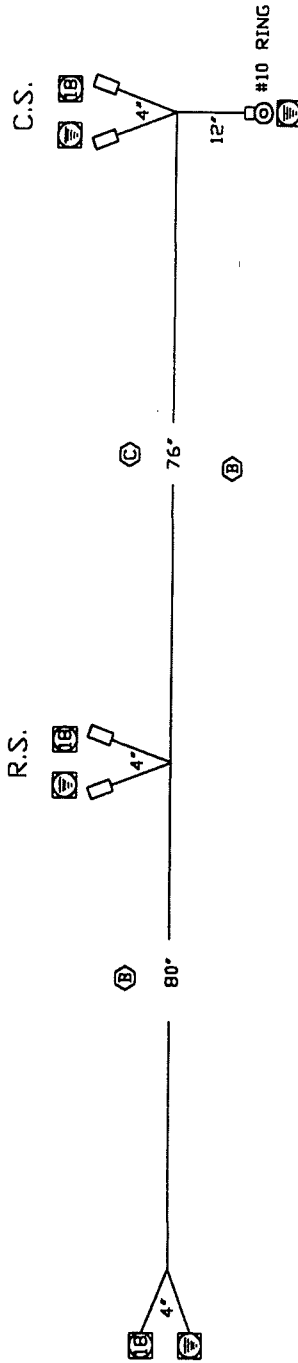

NOTE:  
WIRE SHALL BE TEV 105°C UL & CSA  
HARNES SHALL CONFORM TO 951066 SPEC.

Terminals	
	Bullet .180 Male
	Bullet .180 Female
	Butt Connector
	Org. Molexure
	Spade .250 Female
	Spade .250 Male

- = 20 Ga Wire
- = 18 Ga Wire
- = 16 Ga Wire
- = 14 Ga Wire
- = 12 Ga Wire
- = 10 Ga Wire
- = 8 Ga Wire

ITEM	QTY	DESCRIPTION	QTY
<b>Airstream</b>			
TOLERANCES		DRAWN BY	
±		RLA	
NEXT ASSY		APPROVED BY	
		R.A.	
PRODUCT LINE 1994-A/S TRAILER			
TITLE HARNES, FRNT. CLR. LT.			
SCALE		DATE	
1=M		05/08/90	
		DRAWING NUMBER	
		510907	
		REV.	
		C	

LET DATE	E.C.N.	REVISION RECORD	BY
1/98	4702	Production Release	RA

511379

Weight: 11 Lbs.

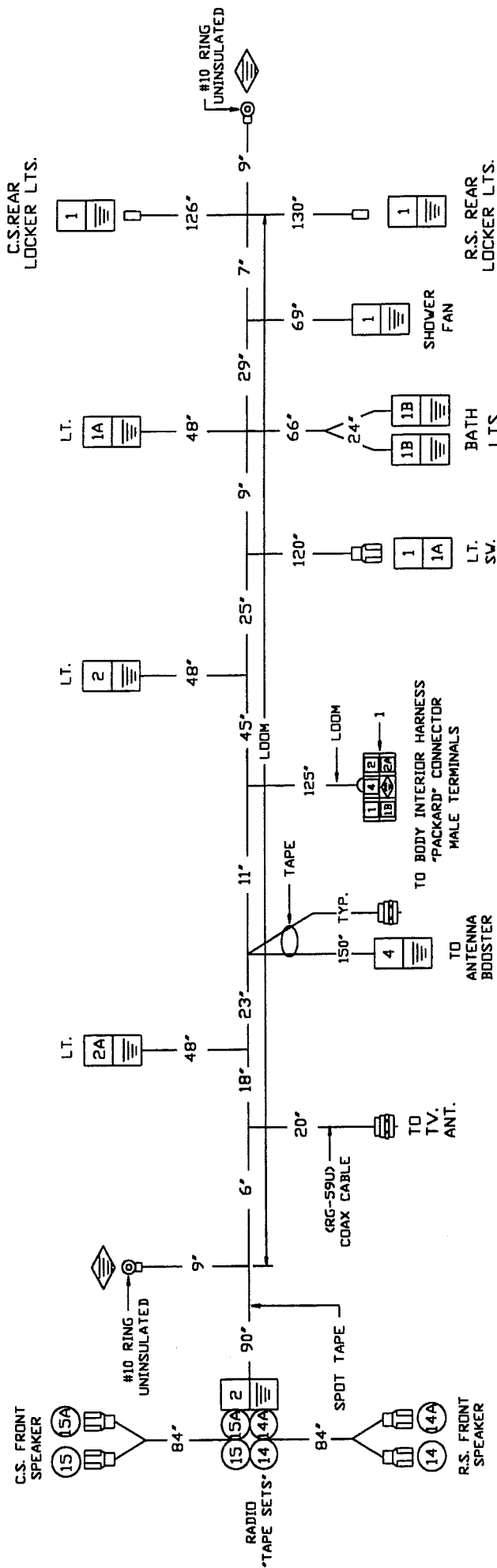

REAR

FRONT

Wire Gauge Chart

□	= 20 Ga. Wire	□	= 14 Ga. Wire
○	= 18 Ga. Wire	□	= 12 Ga. Wire
◇	= 16 Ga. Wire	◇	= 10 Ga. Wire
△	= 8 Ga. Wire		

NOTE:  
 1. ALL CONNECTORS ARE WIRE SIDE VIEW.  
 2. ALL WIRES TO BE TEV UL/CSA.  
 3. GROUND WIRES TO BE WHITE.  
 4. ALL TERMINALS ARE INSULATED UNLESS NOTED.

No.	Ga.	Color	Function
1	12	Purple	+12V.
1A	12	Purple/whit.	Bath. Ceiling Lt.
1B	12	Purple/blk.	Bath Light
2	12	Yellow	+12V.
2A	12	Yellow/blk.	Forward Ceiling Lt
4	12	Brown	+12V.
14	18	Blue	RS Spkr.(Front +)
14A	18	Black	RS Spkr.(Front -)
15	18	Red	CS Spkr.(Front +)
15A	18	Black	CS Spkr.(Front -)

Terminals

□	Spade .110 Female
□	Bullet .180 Male
□	Bullet .180 Female
□	Bullet .156 Female
□	Bullet .156 Male
□	Butt Connector
□	Ring Connector
□	Spade .250 Female
□	Spade .250 Male
□	Coax Connector

2	510833-03	TERMINAL MALE 10-12 #2977994	6 EA
1	510837-01	CONNECTOR 6-WAY, MALE, #2977042	1 EA
TOLERANCES		DESCRIPTION	QTY
±.1"			UM
NEXT ASSY		DRAWN BY	
		R.L.A.	
		APPROVED BY	
TITLE			
Harness, Ceiling			
SCALE	DATE	DRAWING NUMBER	REV.
None	08/04/97	511379	C

Weight: 18 Lbs.

LET	DATE	E.C.N.	REVISION RECORD	BY
A	1/98	4702	Production Release	RA
	11/98	4734	Moved Cir. 79, BT - ADD GRND.	RA

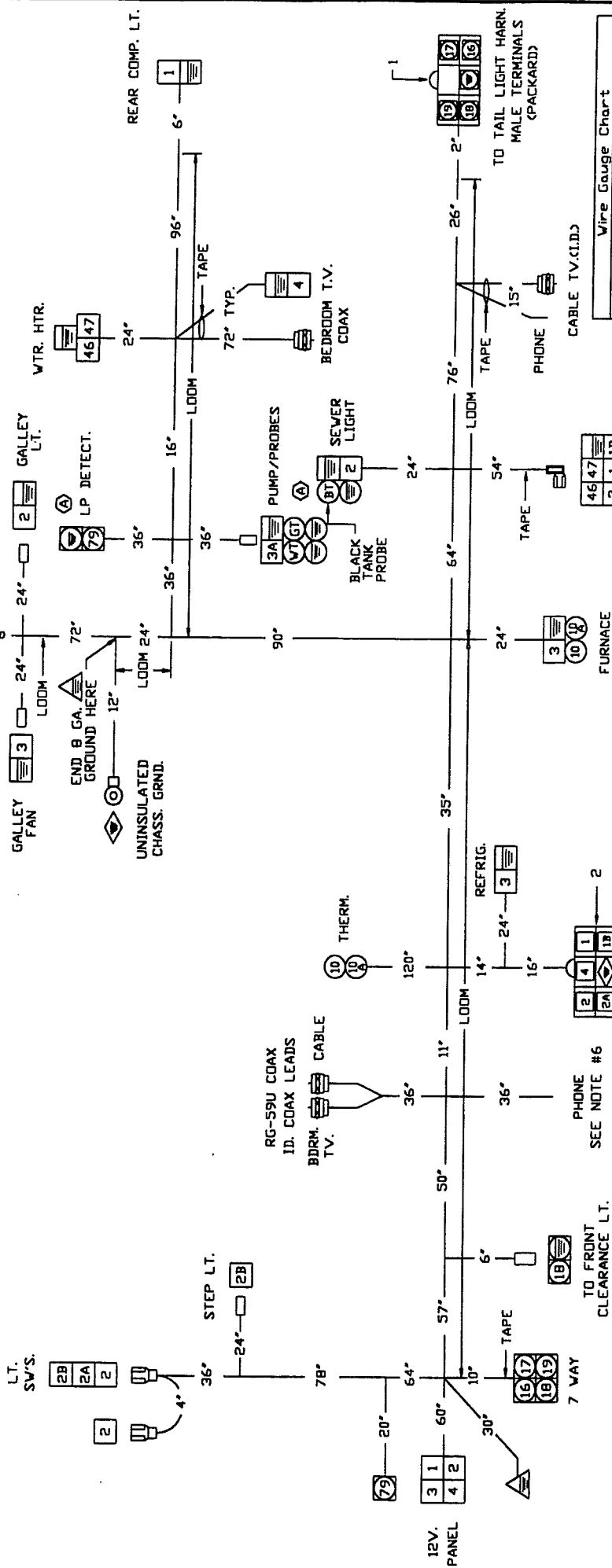

Wire Gauge Chart

□	= 20 Ga Wire
○	= 18 Ga Wire
◇	= 16 Ga Wire
△	= 8 Ga Wire

ITEM	PART NUMBER	DESCRIPTION	QTY	UM
5	510834-04	TERMINAL FEMALE 10 #6288913	1	EA
4	510834-03	TERMINAL FEMALE 12 #2965143	5	EA
3	510833-02	TERMINAL MALE 14-16 #2971962	5	EA
2	510837-02	CONNECTOR 6-WAY, FEMALE #2977044	1	EA
1	510837-01	CONNECTOR 6-WAY, MALE #2977042	1	EA

**Airstream**

PRODUCT LINE 23' Safari Tr.L. 'C'

TOLERANCES ± 1"

NEXT ASSY

TITLE **Harness, Body, Interior**

SCALE None

DATE 08/04/97

DRAWING NUMBER 511380-01

REV. C

APPROVED BY R.L.A.

DRAWN BY

Terminals

▶	Bullet 180 Male
◀	Bullet 180 Female
◻	Butt Connector
◉	Ring 250 I.D.
◊	Spade 250 Female
◻	Spade 250 Male
◻	Rt. Angle-insulated
◻	Spade 250 Male
◻	Coax Connector

No	Ga	Color	Function
1	12	Purple	12V. Feed
1B	12	Purple/blk.	Bath Light
2	12	Yellow	12V. Feed
2A	12	Yellow/blk.	Forward Galina Lt
2B	12	Yellow/red	Step Lt.
3	12	Pink	12V. Feed
3A	12	Orange/wht.	Water Pump
4	12	Brown	12V. Feed
10	18	Blue	Thermostat
11	18	Blue/wht.	Thermostat
12	18	Black	Back-up Lights
13	14	Red	Lt. Turn & Stop
14	14	Green	L.P. & Tail Lys.
15	14	Green	St. Turn & Stop
16	14	Brown/wht.	Water Heater
17	12	Blue/wht.	Water Heater
18	18	Black/wht.	LP Detector
19	18	Green	Black Tank
20	18	Red	Gray Tank
21	18	Red	Water Tank

TO CEILING HARNESS 'PACKARD'S CONNECTORS TYP. FEMALE TERMS.

PHONE SEE NOTE #6

TO FRONT CLEARANCE L.T. HARNESS

NOTE:

- ALL CONNECTORS ARE WIRE SIDE VIEW.
- ALL WIRE TO BE TEV 105° C UL/CSA.
- GROUND WIRES TO BE WHITE.
- HARNESS SHALL CONFORM TO DIVG. 951066 SPECIFICATIONS.
- TELEPHONE CABLE TO BE STANDARD 22 GA. SOLID, CONSISTING OF RED, GREEN, YELLOW AND BLACK WIRES.
- ALL TERMS. ARE INSULATED UNLESS NOTED.

**23' C SAFARI TRAVEL TRAILER, 12V. CALCULATIONS, FEB. 3, 1998**

**CIRCUIT 1, 20 AMP., 12 GA. PURPLE**

CURBSIDE COMPARTMENT LIGHT	1.00
REAR COMP. LIGHT	1.00
2-BULB BEDROOM CEILING LIGHT	2.88
(2) 2-BULB BATH LIGHTS	5.76
#3 2-BULB CEILING LIGHT	2.88
BATH FAN	1.10
(2) 1-BULB BEDROOM LOCKER LIGHTS	<u>1.88</u>
TOTAL	16.50 AMPS.

**CIRCUIT 2, 20 AMP., 12 GA. YELLOW**

CURBSIDE, 2-BULB FRONT LOCKER LIGHT	2.88
STEP LIGHT	1.00
2-BULB GALLEY LOCKER LIGHT	0.90
RADIO	1.67
ROADSIDE, 2-BULB FRT. LOCKER LIGHT	2.88
#1 2-BULB CEILING LIGHT	2.88
SEWER AREA LIGHT	1.00
#2 2-BULB CEILING LIGHT	<u>2.88</u>
TOTAL	16.09 AMPS.

**CIRCUIT 3, 20 AMP., 12 GA PINK**

WATER PUMP	7.00
FURNACE	6.50
RANGE HOOD LIGHT	0.70
RANGE HOOD FAN	1.10
REFER LIGHT	0.50
OPT. OVEN LIGHT	1.00
WATER HEATER IGNITION	<u>1.00</u>
TOTAL	17.80 AMPS.

**CIRCUIT 4, 20 AMP., 12 GA. BROWN**

BREAK-AWAY SWITCH	0.00
HITCH JACK MOTOR (MOMENTARY)	8.00
BEDROOM TV JACK	5.00
FRONT TV JACK/BOOSTER	<u>5.00</u>
TOTAL	18.00 AMPS.

3 AMP. BATTERY CHARGER

Weight: 11 Lbs.

LET	DATE	E.C.N.	REVISION RECORD	BY
A	10/96	4618	Production Release	RA
B	12/96	4618A	Add #2 Circuit For #2 Ceiling Lt.	RA
B	1/98	4698	Del. Fan Cir's., Gnd., Was 12 Ga.	RA

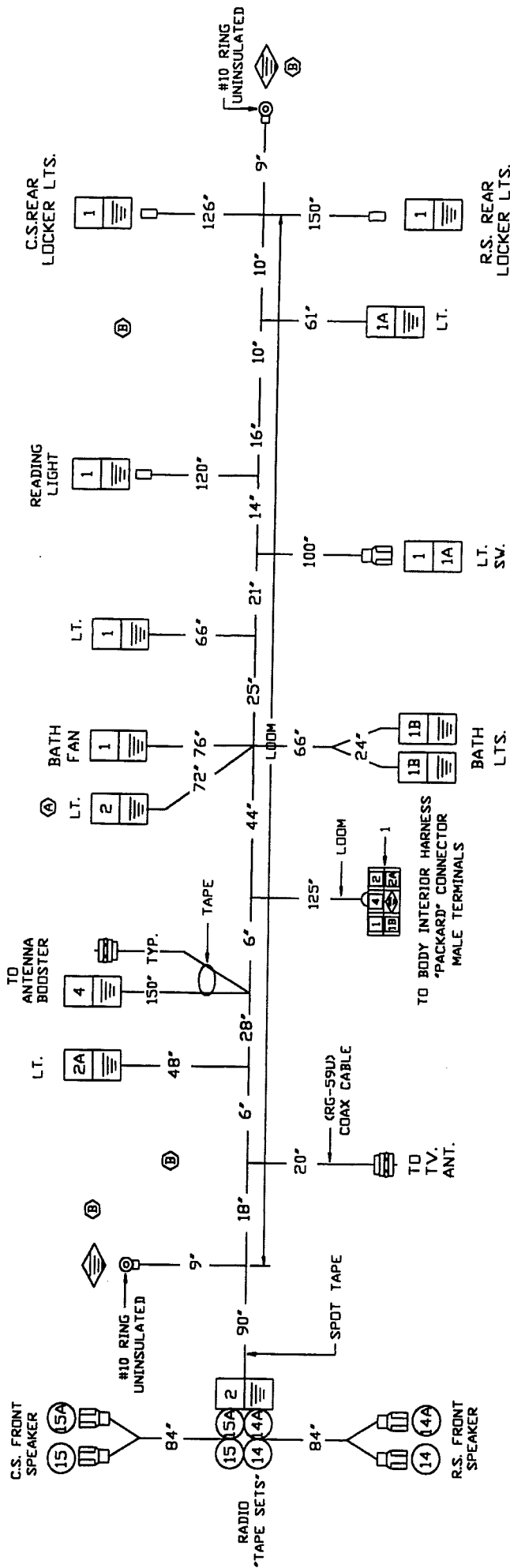

FRONT

REAR

Wire Gauge Chart

□	= 20 Ga Wire	○	= 14 Ga Wire
○	= 18 Ga Wire	◇	= 12 Ga Wire
◇	= 16 Ga Wire	△	= 10 Ga Wire
			= 8 Ga Wire

- NOTE:
1. ALL CONNECTORS ARE WIRE SIDE VIEW.
  2. ALL WIRES TO BE TEV UL/CSA.
  3. GROUND WIRES TO BE WHITE.
  4. ALL TERMINALS ARE INSULATED UNLESS NOTED.

No.	Ga.	Color	Function
1	12	Purple	+12V.
1A	12	Purple/wht.	Bath. Ceiling Lt.
1B	12	Purple/blk.	Bath Light
2	12	Yellow	+12V.
2A	12	Yellow/blk.	Forward Ceiling Lt.
4	12	Brown	+12V.
14	18	Blue	RS Spkr.(Front →)
14A	18	Black	CS Spkr.(Front →)
15	18	Red	CS Spkr.(Front →)
15A	18	Black	CS Spkr.(Front →)

Terminals

□	Spade .110 Female
○	Bullet .180 Male
◇	Bullet .180 Female
◇	Bullet .156 Male
◇	Bullet .156 Female
◇	Ring Connector
◇	Butt Connector
◇	Spade .250 Female
◇	Spade .250 Male
◇	Coax Connector

2	510833-03	TERMINAL MALE 10-12 #2977994	6 EA
1	510837-01	CONNECTOR 6-WAY, MALE, #2977042	1 EA
TOLERANCES			
± 1/16"	DESCRIPTION		
DRAWN BY R.L.A.			
APPROVED BY			
TITLE Airstream			
PRODUCT LINE 25' Safari Tri.			
SCALE None			
DATE 09/26/96			
DRAWING NUMBER 511334-02			
REV. C			B



511335-05

Weight: 23 Lbs.

TO CONTROL PANEL

LET	DATE	E.C.N.	REVISION RECORD	BY
A	10/96	4618	Production Release	RA
B	12/96	4618A	Length And Break-Out Changes	RA
B	3/97	4648F	Move Bdrm. TV #2 Bld.	RA
C	4/97	4654	54" Was 30", Del. 3 & 12 Pin Conn. RA	RA
D	11/97	4688H	Relocate Cir. 3A, 90" Was 96"	RA
E	11/98	4734	Moved Cir. 79	RA

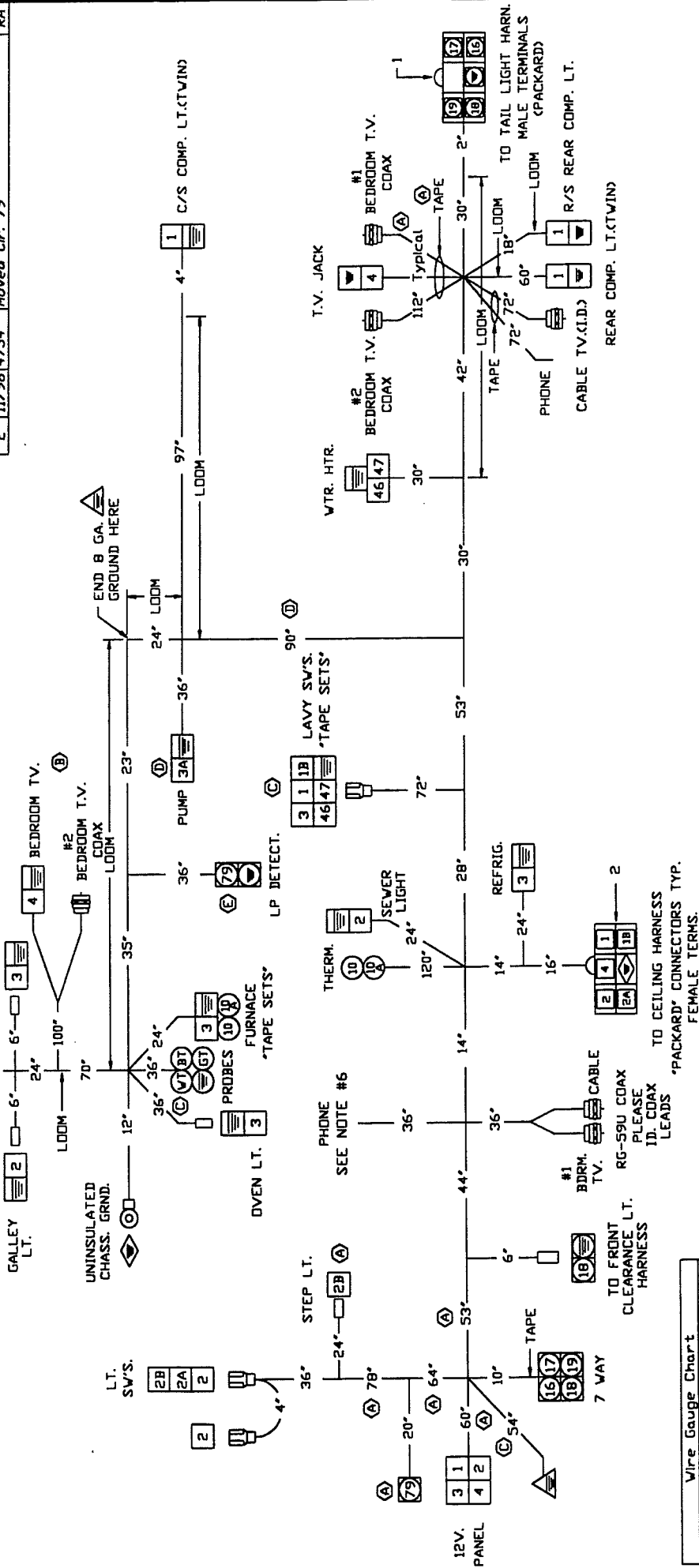

No.	Ga.	Color	Function
1	12	Purple	12V. Feed
1B	12	Purple/blk.	Bath Light
2	12	Yellow	12V. Feed
2A	12	Yellow/blk.	Forward Galbra Lt.
2B	12	Yellow/red	Step Lt.
3	12	Pink	12V. Feed
3A	12	Orange/wht.	Water Pump
3B	12	Green	12V. Feed
3C	12	Blue/wht.	Water Heater
3D	12	Black	12V. Feed
3E	12	Black	12V. Feed
3F	12	Black	12V. Feed
3G	12	Black	12V. Feed
3H	12	Black	12V. Feed
3I	12	Black	12V. Feed
3J	12	Black	12V. Feed
3K	12	Black	12V. Feed
3L	12	Black	12V. Feed
3M	12	Black	12V. Feed
3N	12	Black	12V. Feed
3O	12	Black	12V. Feed
3P	12	Black	12V. Feed
3Q	12	Black	12V. Feed
3R	12	Black	12V. Feed
3S	12	Black	12V. Feed
3T	12	Black	12V. Feed
3U	12	Black	12V. Feed
3V	12	Black	12V. Feed
3W	12	Black	12V. Feed
3X	12	Black	12V. Feed
3Y	12	Black	12V. Feed
3Z	12	Black	12V. Feed

No.	Ga.	Color	Function
1	12	Purple	12V. Feed
1B	12	Purple/blk.	Bath Light
2	12	Yellow	12V. Feed
2A	12	Yellow/blk.	Forward Galbra Lt.
2B	12	Yellow/red	Step Lt.
3	12	Pink	12V. Feed
3A	12	Orange/wht.	Water Pump
3B	12	Green	12V. Feed
3C	12	Blue/wht.	Water Heater
3D	12	Black	12V. Feed
3E	12	Black	12V. Feed
3F	12	Black	12V. Feed
3G	12	Black	12V. Feed
3H	12	Black	12V. Feed
3I	12	Black	12V. Feed
3J	12	Black	12V. Feed
3K	12	Black	12V. Feed
3L	12	Black	12V. Feed
3M	12	Black	12V. Feed
3N	12	Black	12V. Feed
3O	12	Black	12V. Feed
3P	12	Black	12V. Feed
3Q	12	Black	12V. Feed
3R	12	Black	12V. Feed
3S	12	Black	12V. Feed
3T	12	Black	12V. Feed
3U	12	Black	12V. Feed
3V	12	Black	12V. Feed
3W	12	Black	12V. Feed
3X	12	Black	12V. Feed
3Y	12	Black	12V. Feed
3Z	12	Black	12V. Feed

Wire Gauge Chart

□ = 20 Ga Wire    ○ = 14 Ga Wire  
 ○ = 18 Ga Wire    □ = 12 Ga Wire  
 ○ = 16 Ga Wire    ◇ = 10 Ga Wire  
 △ = 8 Ga Wire

#1. ALL CONNECTORS ARE WIRE SIDE VIEW.  
 #2. ALL WIRE TO BE TEV 105° C UL/CSSA.  
 #3. GROUND WIRES TO BE WHITE.  
 #4. HARNESS SHALL CONFORM TO DWG. 951066 SPECIFICATIONS.  
 #5. TELEPHONE CABLE TO BE STANDARD 22 GA. SOLID,  
 (4) CONDUCTOR WITH JACKET FOR TELE. JACK,  
 CONSISTING OF RED, GREEN, YELLOW AND BLACK WIRES.  
 #6. ALL TERMS. ARE INSULATED UNLESS NOTED.

ITEM	PART NUMBER	DESCRIPTION	QTY	UM
5	510834-04	TERMINAL FEMALE 10 #6288913	1	EA
4	510834-03	TERMINAL FEMALE 12 #2965143	5	EA
3	510833-02	TERMINAL MALE 14-16 #2971962	5	EA
2	510837-02	CONNECTOR 6-WAY, FEMALE, #2972044	1	EA
1	510837-01	CONNECTOR 6-WAY, MALE, #2972042	1	EA

TOLERANCES	DRAWN BY
± .1"	R.L.A.
NEXT ASS'Y	APPROVED BY

TITLE	DATE	DRAWING NUMBER	REV.
Harness, Body, Interior	10/01/96	511335-05	C E

ITEM	PART NUMBER	DESCRIPTION	QTY	UM
5	510834-04	TERMINAL FEMALE 10 #6288913	1	EA
4	510834-03	TERMINAL FEMALE 12 #2965143	5	EA
3	510833-02	TERMINAL MALE 14-16 #2971962	5	EA
2	510837-02	CONNECTOR 6-WAY, FEMALE, #2972044	1	EA
1	510837-01	CONNECTOR 6-WAY, MALE, #2972042	1	EA

TOLERANCES	DRAWN BY
± .1"	R.L.A.
NEXT ASS'Y	APPROVED BY

TITLE	DATE	DRAWING NUMBER	REV.
Harness, Body, Interior	10/01/96	511335-05	C E

ITEM	PART NUMBER	DESCRIPTION	QTY	UM
5	510834-04	TERMINAL FEMALE 10 #6288913	1	EA
4	510834-03	TERMINAL FEMALE 12 #2965143	5	EA
3	510833-02	TERMINAL MALE 14-16 #2971962	5	EA
2	510837-02	CONNECTOR 6-WAY, FEMALE, #2972044	1	EA
1	510837-01	CONNECTOR 6-WAY, MALE, #2972042	1	EA

Weight: 23 Lbs.

LET	DATE	E.C.N.	REVISION RECORD	BY
A	4/97	4634	Production Release	RA
B	5/97	4664H	Add Rt. Angle Term. Din. Lt. B.D. RA	RA
C	11/97	4688H	Move Bdrm. & Cable TV Coax B.D. RA	RA
D	1/98	4698	Move Cir. 3A, 90° Was 96°, 60° Was 48°	RA
E	1/98	4698	25° Was 15°	RA
F	11/98	4734	Moved Cir. 79	RA

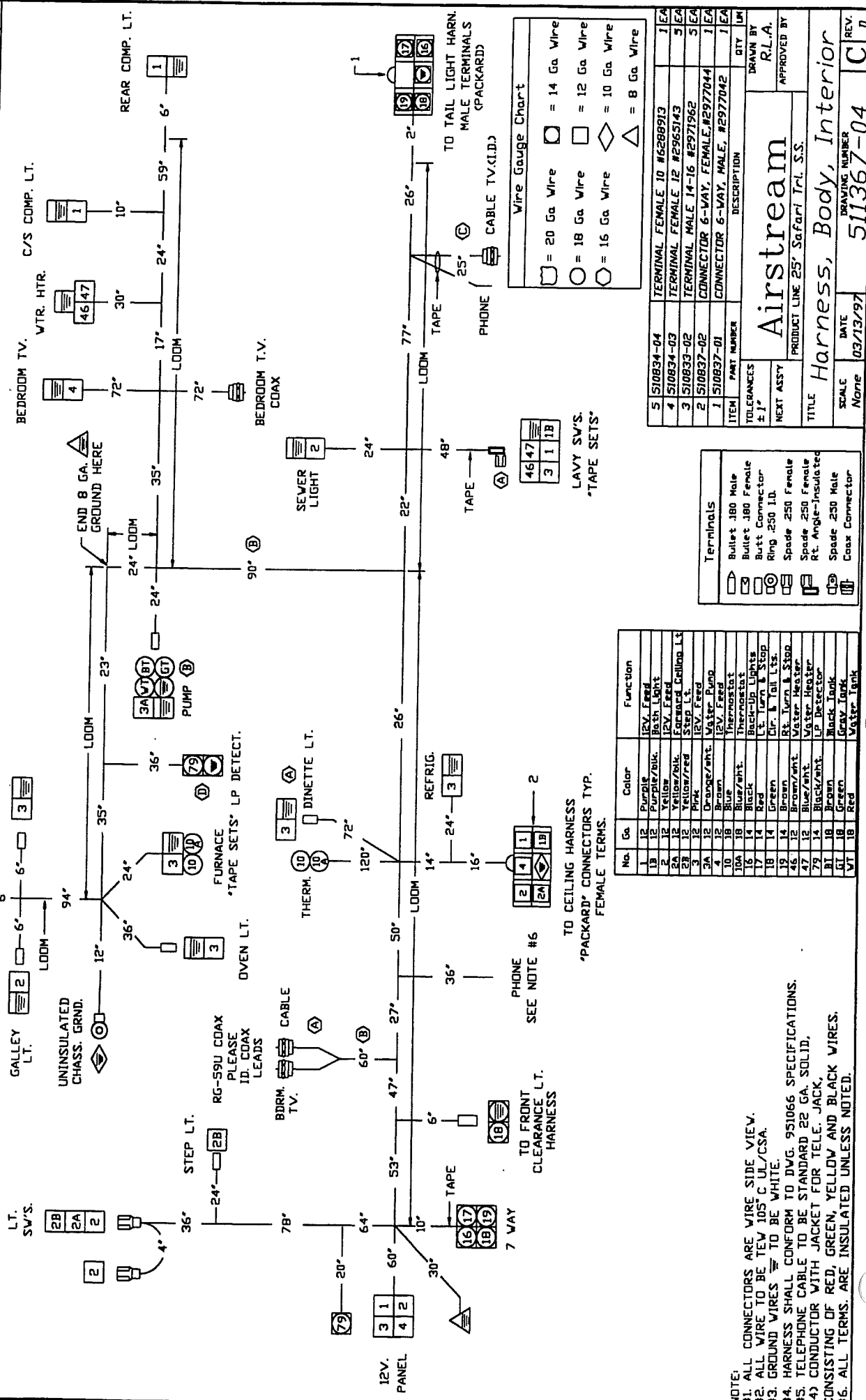

NOTE:  
 #1. ALL CONNECTORS ARE WIRE SIDE VIEW.  
 #2. ALL WIRE TO BE TEW 105' C UL/CSA.  
 #3. GROUND WIRES TO BE WHITE.  
 #4. HARNESS SHALL CONFORM TO DWG. 951066 SPECIFICATIONS.  
 #5. TELEPHONE CABLE TO BE STANDARD 22 GA. SOLID, CONSISTING OF RED, GREEN, YELLOW AND BLACK WIRES.  
 #6. ALL TERMS. ARE INSULATED UNLESS NOTED.

ITEM	PART NUMBER	DESCRIPTION	QTY	U/M
5	510834-04	TERMINAL FEMALE 10 #6288913	1	EA
4	510834-03	TERMINAL FEMALE 12 #2965143	5	EA
3	510833-02	TERMINAL MALE 14-16 #2971962	2	EA
2	510837-02	CONNECTOR 6-WAY, FEMALE, #2977044	1	EA
1	510837-01	CONNECTOR 6-WAY, MALE, #2977042	1	EA

WIRE GAUGE CHART

TO FRONT CLEARANCE LT. HARNESS

TO CEILING HARNESS "PACKARD" CONNECTORS TYP. FEMALE TERMS.

PHONE SEE NOTE #6

TO TAIL LIGHT HARN. MALE TERMINALS "PACKARD"

PHONE CABLE TV (I.D.)

WIRE GAUGE CHART

□ = 20 Ga Wire

○ = 18 Ga Wire

◇ = 16 Ga Wire

△ = 14 Ga Wire

TERMINALS

- Bullet 180 Male
- Bullet 180 Female
- ◇ Butt Connector
- △ Ring 250 I.D.
- Spade 250 Female
- Spade 250 Female Rt. Angle-Insulated
- ◇ Spade 250 Male
- △ Coax Connector

TOLERANCES ± 1/16"

NEXT ASSY

PRODUCT LINE 25' Safari Int. S.S.

SCALE None

DATE 03/13/97

DRAWING NUMBER 511367-04

TITLE Harness, Body, Interior

APPROVED BY R.L.A.

DRAWN BY

**25' SB SAFARI TRAVEL TRAILER, 12V. CALCULATIONS, JAN. 26, 1998**

**CIRCUIT 1, 20 AMP., 12 GA. PURPLE**

CURBSIDE COMPARTMENT LIGHT	1.00
REAR COMP. LIGHT	1.00
2-BULB BEDROOM CEILING LIGHT	2.88
(2) 2-BULB BATH LIGHTS	5.76
#3 2-BULB CEILING LIGHT	2.88
BATH FAN	1.10
(2) 1-BULB BEDROOM LOCKER LIGHTS	<u>1.88</u>
TOTAL	16.50 AMPS.

**CIRCUIT 2, 20 AMP., 12 GA. YELLOW**

CURBSIDE, 2-BULB FRONT LOCKER LIGHT	2.88
STEP LIGHT	1.00
2-BULB GALLEY LOCKER LIGHT	0.90
RADIO	1.67
ROADSIDE, 2-BULB FRT. LOCKER LIGHT	2.88
#1 2-BULB CEILING LIGHT	2.88
SEWER AREA LIGHT	1.00
#2 2-BULB CEILING LIGHT	<u>2.88</u>
TOTAL	16.09 AMPS.

**CIRCUIT 3, 20 AMP., 12 GA PINK**

WATER PUMP	7.00
FURNACE	6.50
RANGE HOOD LIGHT	0.70
RANGE HOOD FAN	1.10
REFER LIGHT	0.50
OPT. OVEN LIGHT	1.00
WATER HEATER IGNITION	<u>1.00</u>
TOTAL	17.80 AMPS.

**CIRCUIT 4, 20 AMP., 12 GA. BROWN**

BREAK-AWAY SWITCH	0.00
HITCH JACK MOTOR (MOMENTARY)	8.00
BEDROOM TV JACK	5.00
FRONT TV JACK/BOOSTER	<u>5.00</u>
TOTAL	18.00 AMPS.

3 AMP. BATTERY CHARGER

Weight: 14 Lbs.

LET	DATE	E.C.N.	REVISION RECORD	BY
	12/97	4693	Production Release	RA

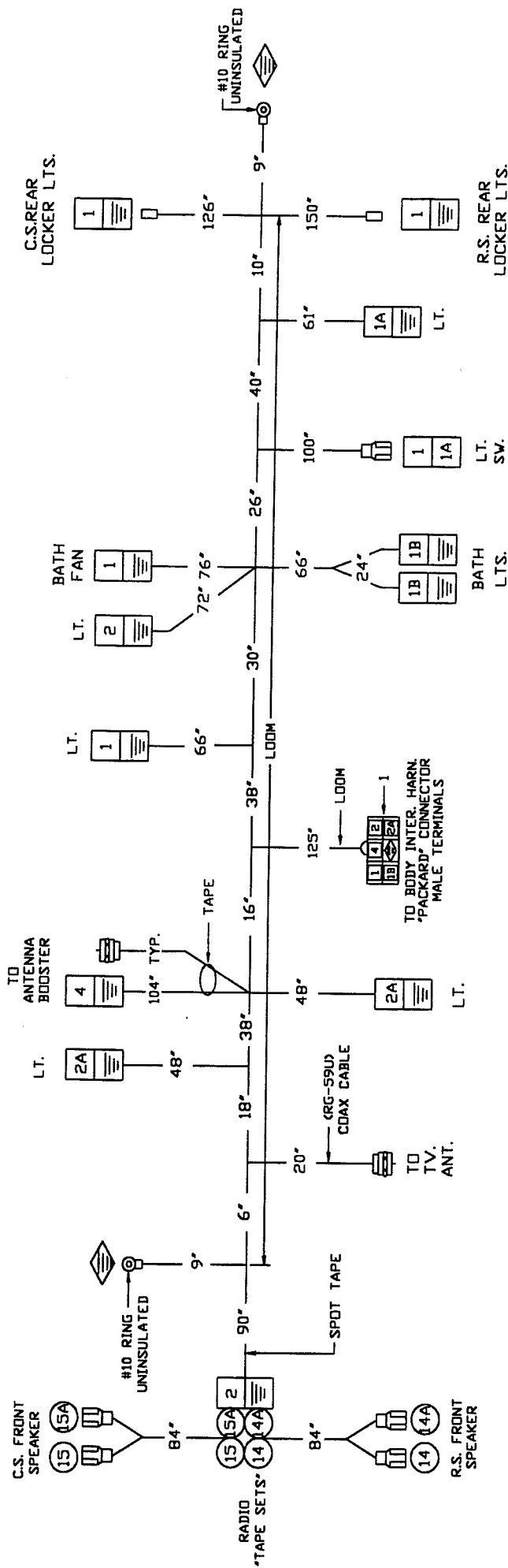

FRONT

REAR

Wire Gauge Chart

□	= 20 Ga Wire	○	= 14 Ga Wire
○	= 18 Ga Wire	□	= 12 Ga Wire
◇	= 16 Ga Wire	△	= 10 Ga Wire
			= 8 Ga Wire

NOTE:  
 1. ALL CONNECTORS ARE WIRE SIDE VIEW.  
 2. ALL WIRES TO BE TEV UL/CSA.  
 3. GROUND WIRES TO BE WHITE.  
 4. ALL TERMINALS ARE INSULATED UNLESS NOTED.

No.	Ga	Color	Function
1	12	Purple	+12V.
1A	12	Purple/whit.	Bdrm. Ceiling L.t.
1B	12	Purple/blk.	Bath Lights
2	12	Yellow	+12V.
2A	12	Yellow/blk.	Forward Ceiling L.t.s.
4	12	Brown	+12V.
14	18	Blue	RS Soker(Front →)
14A	18	Black	RS Soker(Front →)
15	18	Red	CS Soker(Front →)
15A	18	Black	CS Soker(Front →)

Terminals

□	Spade .110 Female
○	Bullet .180 Male
◇	Bullet .180 Female
△	Bullet .156 Female
□	Bullet .156 Male
○	Butt Connector
◇	Ring Connector
△	Spade .250 Female
□	Spade .250 Male
○	Coax Connector

2	510933-03	TERMINAL MALE 10-12 #2977994	6 EA
1	510937-01	CONNECTOR 6-WAY, MALE, #2977042	1 EA
TOLERANCES		DESCRIPTION	QTY UN
NEXT ASSY		DRAWN BY	R.L.A.
TITLE		APPROVED BY	
None		DATE	09/26/97
SCALE		DRAWING NUMBER	511381
		REV.	C

**Airstream**  
 Harness, Ceiling

511382-01

Weight: 24 Lbs.

LET	DATE	E.C.N.	REVISION RECORD	BY
A	12/97	4693	Production Release	RA
	11/98	4734	Moved Cir. 79	RA

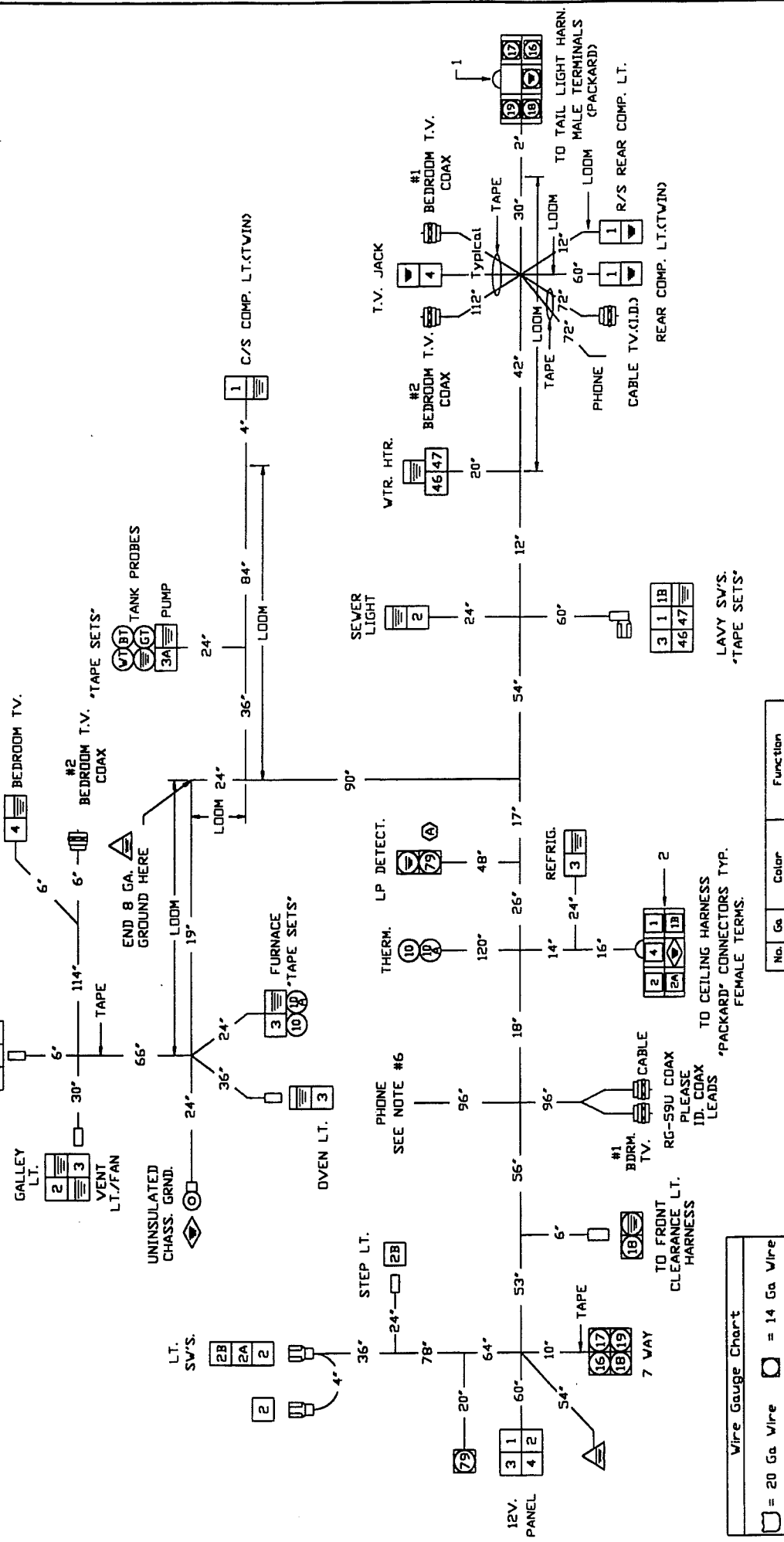

Wire Gauge Chart

[Square]	= 20 Ga. Wire	[Circle]	= 14 Ga. Wire
[Diamond]	= 18 Ga. Wire	[Triangle]	= 12 Ga. Wire
[Circle with horizontal lines]	= 16 Ga. Wire	[Circle with vertical lines]	= 10 Ga. Wire
[Circle with diagonal lines]	= 8 Ga. Wire		

NOTE:  
 #1. ALL CONNECTORS ARE WIRE SIDE VIEW.  
 #2. ALL WIRE TO BE TEV 105°C UL/CSA.  
 #3. GROUND WIRES TO BE WHITE.  
 #4. HARNESS SHALL CONFORM TO DWG. 951066 SPECIFICATIONS.  
 #5. TELEPHONE CABLE TO BE STANDARD 22 GA. SOLID, CONSISTING OF RED, GREEN, YELLOW AND BLACK WIRES.  
 #6. ALL TERMS. ARE INSULATED UNLESS NOTED.

No.	Ga.	Color	Function
1	12	Purple	12V. Feed
1B	12	Purple/black	Bath Light
2	12	Yellow	12V. Feed
2A	12	Yellow/black	Forward Ceiling Lt
3	12	Yellow/red	Step Lt.
3B	12	Pink	12V. Feed
3A	12	Orange/wht.	Water Pump
4	12	Brown	12V. Feed
10	18	Blue	Thermostat
10A	18	Blue/wht.	Thermostat
16	14	Black	Back-Up Lights
17	14	Red	Lt. Turn & Stop
18	14	Green	Lt. Turn & Stop
19	14	Brown	Rt. Turn & Stop
45	12	Brown/wht.	Water Heater
46	12	Blue/wht.	Water Heater
79	14	Black/wht.	LP Detector
BT	18	Brown	Black Tank
GT	18	Green	Gray Tank
VT	18	Red	Water Tank

Terminals

[Square]	Rt. Angle
[Circle]	Spade .250 Female
[Diamond]	Bullet .180 Male
[Circle with horizontal lines]	Bullet .180 Female
[Circle with vertical lines]	Butt Connector
[Circle with diagonal lines]	Ring .250 I.D.
[Circle with dots]	Spade .250 Male
[Circle with cross]	Spade .250 Female
[Circle with asterisk]	Coax Connector

ITEM	PART NUMBER	DESCRIPTION	QTY	UN
5	510834-04	TERMINAL FEMALE 10 #6288913	1	1EA
4	510834-03	TERMINAL FEMALE 12 #2965143	5	5EA
3	510833-02	TERMINAL MALE 14-16 #2971962	5	5EA
2	510837-02	CONNECTOR 6-WAY, FEMALE, #2977014	1	1EA
1	510837-01	CONNECTOR 6-WAY, MALE, #2977042	1	1EA

TOLERANCES  
±.1"

NEXT ASSY

DRAWN BY: R.L.A.  
APPROVED BY:

TITLE: Harness, Body, Interior  
PRODUCT LINE: 27-Safari Trl.

SCALE: None  
DATE: 9/26/97  
DRAWING NUMBER: 511382-01  
REV: C A

**27' SB SAFARI TRAVEL TRAILER, 12V. CALCULATIONS, JAN. 26, 1998**

**CIRCUIT 1, 20 AMP., 12 GA. PURPLE**

CURBSIDE COMPARTMENT LIGHT	1.00
REAR COMP. LIGHT	1.00
2-BULB BEDROOM CEILING LIGHT	2.88
(2) 2-BULB BATH LIGHTS	5.76
#3 2-BULB CEILING LIGHT	2.88
BATH FAN	1.10
(2) 1-BULB BEDROOM LOCKER LIGHTS	<u>1.88</u>
TOTAL	16.50 AMPS.

**CIRCUIT 2, 20 AMP., 12 GA. YELLOW**

CURBSIDE, 2-BULB FRONT LOCKER LIGHT	2.88
STEP LIGHT	1.00
2-BULB GALLEY LOCKER LIGHT	0.90
RADIO	1.67
ROADSIDE, 2-BULB FRT. LOCKER LIGHT	2.88
#1 2-BULB CEILING LIGHT	2.88
SEWER AREA LIGHT	1.00
#2 2-BULB CEILING LIGHT	<u>2.88</u>
TOTAL	16.09 AMPS.

**CIRCUIT 3, 20 AMP., 12 GA PINK**

WATER PUMP	7.00
FURNACE	6.50
RANGE HOOD LIGHT	0.70
RANGE HOOD FAN	1.10
REFER LIGHT	0.50
OPT. OVEN LIGHT	1.00
WATER HEATER IGNITION	<u>1.00</u>
TOTAL	17.80 AMPS.

**CIRCUIT 4, 20 AMP., 12 GA. BROWN**

BREAK-AWAY SWITCH	0.00
HITCH JACK MOTOR (MOMENTARY)	8.00
BEDROOM TV JACK	5.00
FRONT TV JACK/BOOSTER	<u>5.00</u>
TOTAL	18.00 AMPS.

3 AMP. BATTERY CHARGER

LET	DATE	E.C.N.	REVISION RECORD	BY
A	11/97		PRODUCTION RELEASE	I.C.
			ADD 20A GFI BRK.	I.C.

WESTINGHOUSE TT 120 ELGMM 120 VAC  
CLASS CTL ENCLOSED PANELBOARD

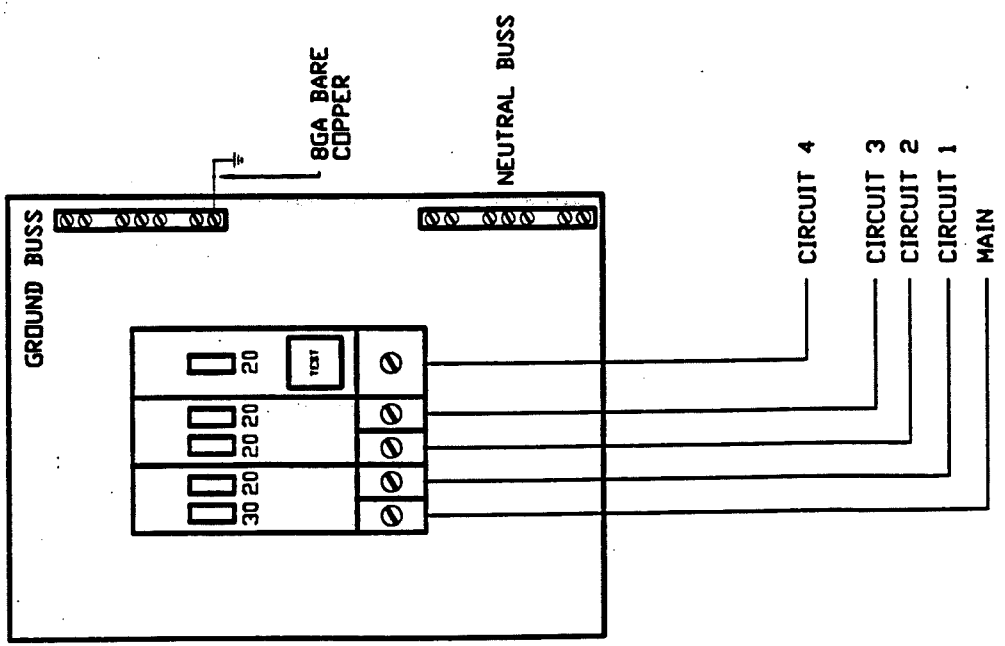

- MAIN**
- CIRCUIT 1, 20 AMP HACR BREAKER, 12-2 ROMEX W/GROUND, AIR CONDITIONER.
  - CIRCUIT 2, 20 AMP HACR BREAKER, 12-2 ROMEX W/GROUND, BEDROOM, LIVING AREA, AND CONVERTER.
  - CIRCUIT 3, 20 AMP HACR BREAKER, 12-2 ROMEX W/GROUND, MICROWAVE OVEN OR DEDICATED ROADSIDE RECEPT.
  - CIRCUIT 4, 20 AMP GFI BREAKER, 12-2 ROMEX W/GROUND, BATH, REFER, GALLEY, AND OUTSIDE RECEPTS.

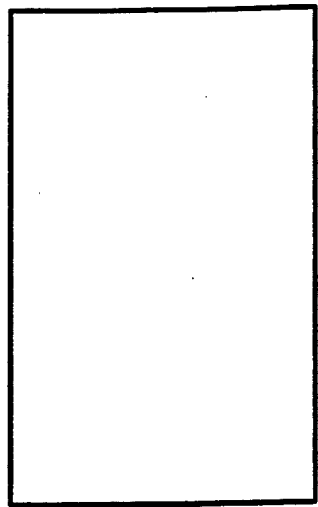

ITEM	PART NUMBER	DESCRIPTION	QTY	UM
TOLERANCES				
±				
NEXT ASS'Y				
DRAWN BY		J.C.		
APPROVED BY				
PRODUCT LINE		BAMBI & SAFARI TRLS.		
TITLE <b>30 AMP. BREAKER PANEL</b>				
SCALE	DATE	DRAWING NUMBER	REV.	
NONE	9/5/96	952585	B	A

952599

LET DATE	E.C.N.	REVISION RECORD	BY
4/97		PRODUCTION RELEASE	TC

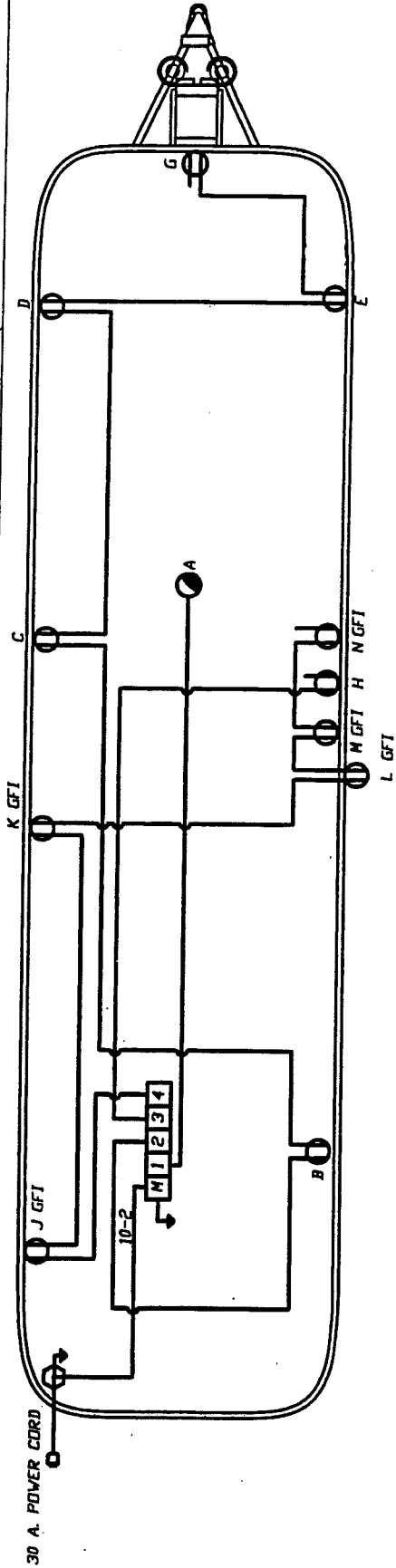

- CIRCUIT 1, 20 AMP. HACR BREAKER, 12-2 ROMEX W/GRD.**  
 A. AIR CONDITIONER 16.0 AMPS.  
**CIRCUIT 2, 20 AMP. HACR BREAKER, 12-2 ROMEX W/ GRD.**  
 B. BEDROOM RECEPT 1.0 AMPS.  
 C. DINETTE/CREDENZA RECEPT 1.0 AMPS.  
 D. ROADSIDE LIVING AREA RECEPT 1.0 AMPS.  
 E. CURBSIDE LIVING AREA RECEPT 1.0 AMPS.  
 G. CONVERTER RECEPT 8.0 AMPS.  
**TOTAL 12.00 AMPS.**

- CIRCUIT 3, 20 AMP. HACR BREAKER, 12-2 ROMEX W/GRD.**  
 H. MICROVAVE RECEPT 12.0 AMPS.  
**CIRCUIT 4, 20 AMP. GFI BREAKER, 12-2 ROMEX W/ GRD.**  
 J. BATH RECEPT. 1.0 AMPS.  
 K. REFER RECEPT. 2.7 AMPS.  
 L. OUTSIDE RECEPT 1.0 AMPS.  
 M. GALLEY RECEPT. 1.0 AMPS.  
 N. GALLEY RECEPT. 1.0 AMPS.  
**TOTAL 6.7 AMPS.**

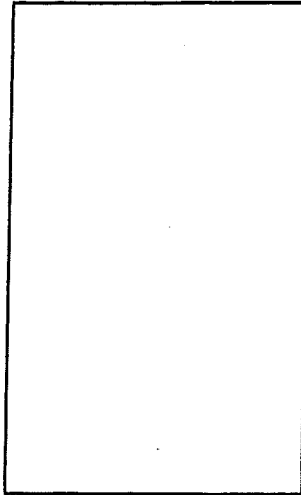

ITEM	PART NUMBER	DESCRIPTION	QTY	UM
TOLERANCES				
±				
NEXT ASS'Y				
DRAWN BY		T.C.		
APPROVED BY				
PRODUCT LINE		23 & 25 C. SAFARI TRL		
TITLE 120 Volt LAYOUT USA				
SCALE	DATE	DRAWING NUMBER	REV.	
1=32	4/1/97	952599	B	



LET	DATE	E.C.N.	REVISION RECORD	BY
	9/96		PRODUCTION RELEASE	TC

952584

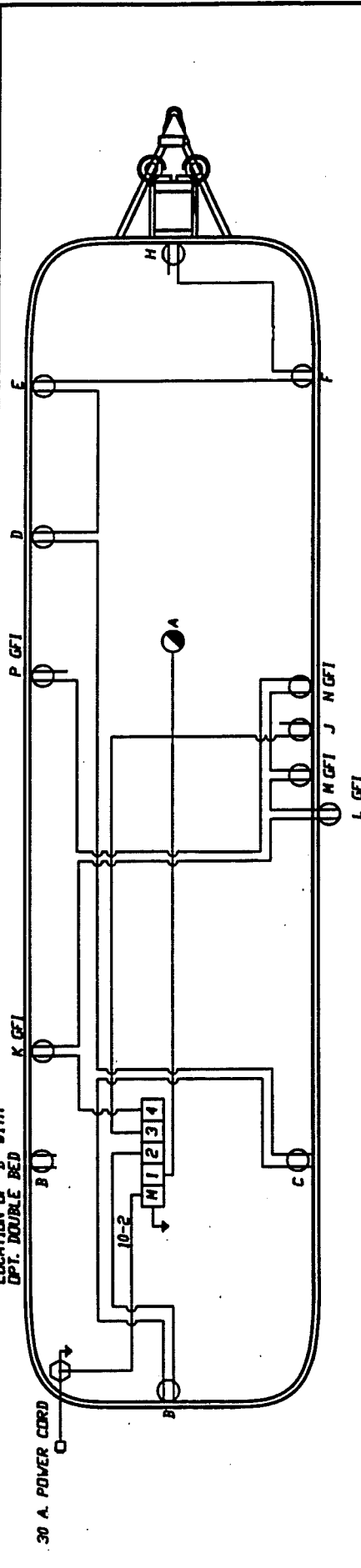

- CIRCUIT 1. 20 AMP. HACR BREAKER, 12-2 ROMEX V/GRD.  
A. AIR CONDITIONER 16.0 AMPS.
- CIRCUIT 2. 20 AMP. HACR BREAKER, 12-2 ROMEX V/ GRD.  
B. BEDROOM RECEPT 1.0 AMPS.  
C. BEDROOM TV RECEPT. 0.63 AMPS.  
D. CREWENGA RECEPT. 1.0 AMPS.  
E. ROADSIDE LIVING AREA RECEPT 1.0 AMPS.  
F. CURBSIDE LIVING AREA RECEPT 1.0 AMPS.  
H. CONVERTER RECEPT 8.0 AMPS.  
TOTAL 12.63 AMPS.
- CIRCUIT 3. 20 AMP. HACR BREAKER, 12-2 ROMEX V/GRD.  
J. MICROWAVE RECEPT 12.0 AMPS.
- CIRCUIT 4. 20 AMP. GFI BREAKER, 12-2 ROMEX V/ GRD.  
K. BATH RECEPT. 1.0 AMPS.  
L. OUTSIDE RECEPT. 1.0 AMPS.  
M. GALLEY RECEPT. 1.0 AMPS.  
N. GALLEY RECEPT. 1.0 AMPS.  
P. REFER RECEPT. 2.7 AMPS.  
TOTAL 6.7 AMPS.

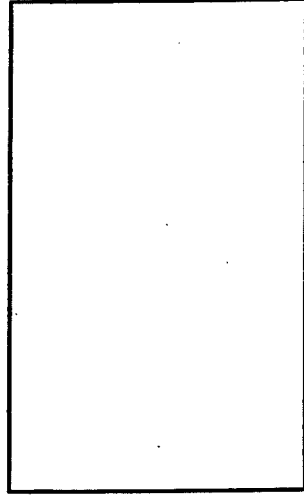

ITEM	PART NUMBER	DESCRIPTION	QTY	UM
TOLERANCES		Airstream	DRAWN BY T.C.	
±			APPROVED BY	
NEXT ASS'Y		PRODUCT LINE 25 SB SAFARI IRL.		
TITLE		120 Volt Lay-out		
SCALE	DATE	DRAWING NUMBER	REV.	
1-32	10/28/96	952584	B	

952618

LET DATE	E.C.N.	REVISION RECORD	BY
1/99	4744	PRODUCTION RELEASE	TC

30 AMP. POWER CORD

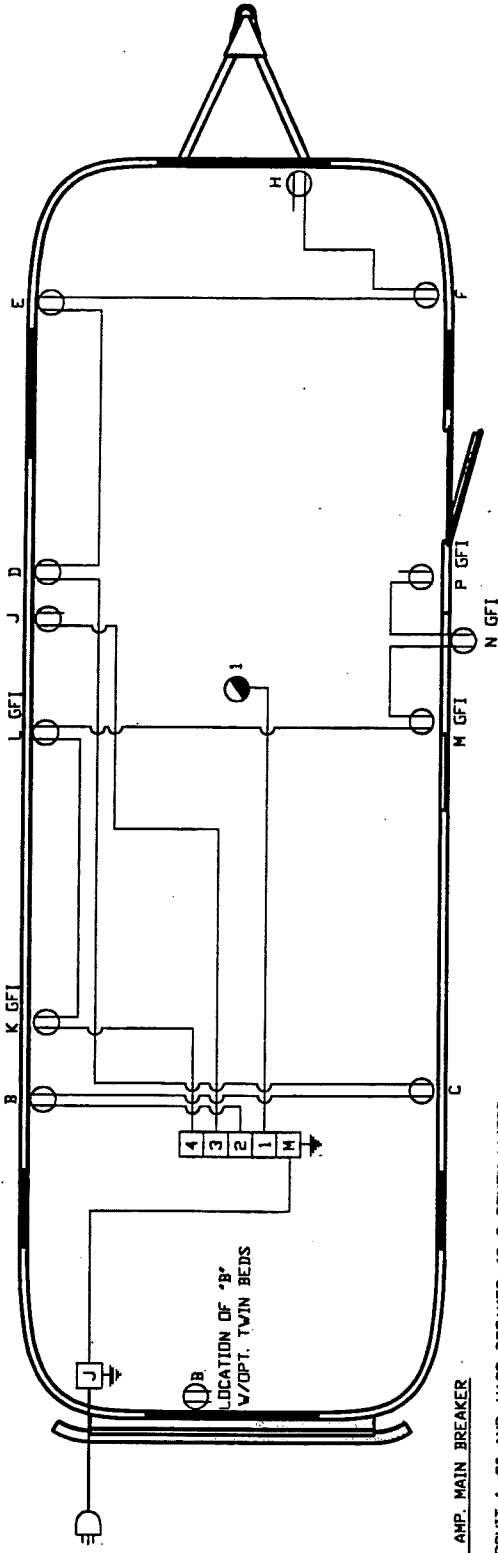

30 AMP. MAIN BREAKER

CIRCUIT 1. 20 AMP HACR BREAKER, 12-2 ROMEX W/GRD.  
A. AIR CONDITIONER 16.0 AMPS.

CIRCUIT 2. 20 AMP HACR BREAKER, 12-2 ROMEX W/GRD.  
B. ROADSIDE BEDROOM RECEPT 1.0 AMPS.  
C. CURBSIDE BEDROOM RECEPT 1.0  
D. PANTRY AREA RECEPT 1.0  
E. ROADSIDE LIVING AREA RECEPT 1.0  
F. CURBSIDE LIVING AREA RECEPT 1.0  
H. CONVERTER 8.0  
TOTAL 13.0 AMPS.

CIRCUIT 3. 20 AMP HACR BREAKER, 12-2 ROMEX W/GRD.  
J. MICROWAVE OVEN RECEPT 12.0 AMPS.

CIRCUIT 4. 20 AMP HACR BREAKER, 12-2 ROMEX W/GRD.  
K. BATHROOM RECEPT 1.0 AMPS.  
L. REFER RECEPT 1.0 AMPS.  
M. GALLEY RECEPT 1.0 AMPS.  
N. OUTSIDE RECEPT 1.0 AMPS.  
P. GALLEY ENDPANEL RECEPT 1.0 AMPS.  
TOTAL 5.0 AMPS.

ITEM	PART NUMBER	DESCRIPTION	QTY	UM
TOLERANCES				
±				
NEXT ASSY				
TITLE	110 V. LAYOUT USA			
SCALE	1=8	DATE	12/11/97	REV.
		DRAWING NUMBER	952618	B

**Airstream**  
FIRST USAGE: 27' SB SAFARI  
APPROVED BY: TC

## APPLIANCES AND EQUIPMENT

### AIR CONDITIONER

Manufacturer: Dometic Sales Corporation  
2320 Industrial Parkway  
P. O. Box 490  
Elkhart, IN 46515  
Phone: 219-295-5228

**Note:** Review the air conditioning literature supplies in your Owner's Packet before proceeding.

The roof air conditioner used on Airstream trailers is one of the most popular on the market today. In your Owner's Packet is a set of literature covering all operating and maintenance instructions. If the literature is misplaced please contact the air conditioner manufacturer or your Airstream dealer for replacement.

The voltage to the air conditioner is critical. We commonly refer to 110 or 120 volts, but a check with a volt meter may find voltage much lower. Your air conditioner will probably not function if the current drops below 105 volts. Low voltage is usually associated with older or poorly maintained trailer parks, but many people have found their homes, built only twenty or thirty years ago, may not be capable of operating the air conditioner on some receptacles. Parking your trailer so the power cord can be plugged into a receptacle close to the fuse or circuit breaker box can alleviate the problem. Avoid extension cords and adapters whenever possible. If an extension cord must be used it should be as short and heavy as possible to provide the most current to the air conditioner.

If high temperatures are expected you should make an effort to park in a shaded area. Starting the air conditioner early in the morning also helps. It is much easier to hold a comfortable temperature than it is to lower the temperature after the interior of the trailer is already hot.

## **FURNACE**

**Manufacturer:** Hydro Flame Corporation  
1874 South Pioneer Road  
Salt Lake City, UT 84104  
Phone: 801-972-4621

The manufacturer of the furnace in your trailer has been well known in the RV industry for many years. The furnace burns LP gas, and is powered by 12 volt current from the battery or power converter when plugged into city power. Operating instructions are located in your Owners Packet. If they should become misplaced, new literature can be ordered direct from the manufacturer or your Airstream dealer. The manufacturer also offers a detailed service guide for your furnace.

**WARNING:** Carefully read all the manufacturer's instructions prior to operating. **NEVER** store flammable material next to the furnace.

**If warranty service is required use only a service location recommended by the furnace manufacturer or your Airstream dealer.**

## RANGE

Manufacturer: Maytag Customer Service  
Maytag Customer Assistance  
P. O. Box 2370  
Cleveland, TN 37320-2370  
Phone: 1-800-544-5513

People using gas ranges in their home will find little difference in the operation of the range in the trailer. Other customers, used to electric ranges may be a little apprehensive at first; but, will quickly gain confidence. The basic operation of the gas ranges have been the same for many years, but please be sure to read all the directions furnished by the manufacturer and located in the Owner's Packet. Excellent service and parts manuals are available from the manufacturer.

**WARNING - The operation manual for the range is titled "Maytag RV Cooking Appliances". If this has not been provided with your trailer, contact the manufacturer listed at the top of the page to obtain. Their manual contains specialized warnings and cautions that should be reviewed prior to operating the appliance.**

## MICROWAVE OVENS

Only federally certified technicians are permitted to service microwave ovens. For this reason the only service instructions contained in this manual are for removal of the complete oven. If you have a microwave problem, please contact the appropriate manufacturer.

Magic Chef  
28812 Phillips Street  
Elkhart, Indiana 46514  
219-264-9578

Litton  
2530 North 2nd Street  
Minneapolis, Minnesota 55411  
605-336-5377

Samsung Electronics America, Inc.  
Service Division  
1 Samsung Place  
Ledgewood, NJ 07852  
1-800-SAMSUNG

Sharp Electronics Corporation  
10 Sharp Plaza  
Paramus, New Jersey 07652  
800-447-4700

Quasar  
Division of Matsushia Elec. Corp.  
1325 Pratt Blvd.  
Elkgrove Village, Illinois 60007  
201-348-9090

Dometic Sales Corporation  
2320 Industrial Parkway  
P.O. Box 490  
Elkhart, IN 46515  
Phone: 219-295-5228

## REFRIGERATOR

Manufacturer: Dometic Sales Corporation  
2320 Industrial Parkway  
P. O. Box 490  
Elkhart, Indiana 46514  
Phone: 219-295-5228

Review all Dometic Literature supplied in your Owner's Packet or stored in the refrigerator prior to operating.

In an absorption refrigerant system ammonia is liquefied in the finned condenser coil at the top rear of the refrigerator. The liquid ammonia then flows into the evaporator (inside the freezer section) and is exposed to a circulating flow of hydrogen gas, which causes the ammonia to evaporate, creating a cold condition in the freezer.

The tubing in the evaporator section is specifically sloped to provide a continuous movement of liquid ammonia, flowing downward by gravity, through this section. If the refrigerator is operated out-of-level when the vehicle is not moving, liquid ammonia will accumulate in portions of the evaporator tubing. This will slow the circulation of hydrogen and ammonia gas, or in severe cases, completely block it, resulting in a loss of cooling.

Any time the vehicle is parked for several hours with the refrigerator operating, the vehicle should be leveled to prevent this loss of cooling. The vehicle needs to be leveled only so it is **comfortable to live in** (no noticeable sloping of floor or walls).

When the vehicle is moving the leveling is not critical, as the rolling and pitching movement of the vehicle will pass to either side of level, keeping the liquid ammonia from accumulating in the evaporator tubing.

## OPERATION

The refrigerator requires 12 volt current to operate even if running on LP or 110 volt modes. The 12 volt is used to power the circuit board that directs the refrigerator functions. When running in a mode such as LP, it means the heat source, by far the largest power requirement, to evaporate the ammonia is being provided by an LP gas burner.

**WARNING: Most LP gas appliances used in recreational vehicles are vented to the outside of the vehicle. When parked close to a gasoline pump, it is possible that gasoline fumes could enter this type of appliance and ignite the burner flame, CAUSING A FIRE OR AN EXPLOSION.**

## **WATER HEATER**

Manufacturer: Atwood Mobile Products  
4750 Hiawatha Drive  
P. O. Box 1205  
Rockford, Illinois 61105  
Phone: 815-877-7461

**Note:** Review the water heater literature supplied in your Owner's Packet before proceeding.

**CAUTION:** Hydrogen gas can be produced in a hot water system served by this heater that has not been used for a long period of time (generally two weeks or more). Hydrogen gas is extremely flammable. To reduce the risk of injury under these conditions, it is recommended that the hot water faucet be opened for several minutes at the kitchen sink before using any electrical appliance connected to the hot water system. If hydrogen is present there will probably be an unusual sound such as air escaping through the pipe as the water begins to flow. There should be no smoking or open flame near the faucet at the time it is open.

### **Electronic Ignition**

The switch used to light your electronic ignition water heater is located in the bathroom above the lavatory top. When the switch is turned on, the red light will come on indicating the "try" mode is in effect. Normally the burner will ignite in just a few seconds, and the light will go out. If your LP system hasn't been used for some time, the system may go into safety lock-out (about 20 seconds) before the air is all expelled from the lines. Turning the switch off for 30 seconds, then back on, reinstates the "try" mode.

### **Principal of Operation**

When the switch is turned on, power is supplied to the thermostat (located inside the junction box at the back of the water heater). When the thermostat senses the water in the tank requires heat (below 120°F), its contacts close and complete the circuit to the circuit board. This will energize the coils in the dual solenoid gas valve, allowing gas to flow out of the main burner orifice, mix with air at the ventura (air adjusting slots), then flow out the end of the main burner.

Simultaneously the coil on the circuit board provides a high voltage current to reach the spark probe at the main burner. This ignites the gas. When the flame is sensed by the probe, current is conducted to the relay and the valve remains energized. Sparking ceases when the electrode to ground current path is altered by the presence of flame. The water heating process begins. When the water in the tank drops below 120°F, the process will automatically repeat itself.



## **SAFETY**

If your water system is full and cold and the water heater is ignited the system can see pressures as high as 120 psi before the relief valve starts to open. Since the water system normally operates in the 40 psi range the water expanding does pose unusual stress on the system. This normally does not cause any problems, but the stress is easily alleviated. As the water is heating just open any faucet and run as little as a cup of water. Just removing this small amount of water reduces the pressure built up significantly.

For fun, watch the sequence of events your family goes through when you park the trailer and ignite the water heater. More than likely someone will run water and relieve the pressure without even realizing it.

## **TV ANTENNA**

Manufacturer: Winegard Company  
3000 Kirkwood Street  
Burlington, Iowa 52601  
Phone: 800-843-4741

### **Raising Antenna to Operating Position**

Turn elevating crank in "UP" direction until some resistance to turning is noted. Antenna is now in operating position. Check to make sure switch on front TV jack is on.

### **Rotating Antenna**

Make sure antenna is in "UP" position. Pull down on directional handle with both hands until it disengages ceiling plate and rotate for best picture and sound on television set.

### **Lowering Antenna to Travel Position**

Rotate antenna until pointer on directional handle aligns with pointer on ceiling plate.

**WARNING: Antenna must be in "down" position while traveling to prevent damage.**

Turn elevating crank in the "Down" direction until resistance is noted. Antenna is now locked in travel position.

### **Checking Operation**

1. Tune TV receiver to nearest station and rotate antenna for lowering Antenna best picture and sound.
2. Turn off switch on power supply. Picture on TV receiver should be considerably degraded with power off.

### **DO'S**

1. Do check parking location for obstructions before raising antenna.
2. Do carefully raise, lower and rotate - if difficult, check for cause.
3. Do rotate slowly when selecting station and check fine tuning on TV set to make sure it is properly adjusted.
4. Do lower antenna before moving vehicle.

### **DON'TS**

1. Don't force elevating crank up or down. Check for cause of trouble.
2. Don't rotate directional handle hard against stops.
3. Don't travel with lift in up position.
4. Don't leave lift part way up or down.
5. Don't apply sealing compound or paint over top of base plate or anywhere on lift.

## SPECIFICATIONS

*Note: All weights were made on prototype vehicles. Your production trailer may vary slightly. More information on weighing and loading your trailer can be found under "Weight Rating" in the forward section of this manual.*

SPECIFICATIONS	23	25C	25A/B	27
Length - Exterior	23' 11"	25' 11"	25' 11"	27' 11"
Width - Exterior	8' 5 1/2"	8' 5 1/2"	8' 5 1/2"	8' 5 1/2"
Width - Interior	8' 1"	8' 1"	8' 1"	8' 1"
Height - Exterior w/AC	9' 7"	9' 7"	9' 7"	9' 7 1/2"
Height - Interior w/AC	6' 3 1/2"	6' 3 1/2"	6' 3 1/2"	6' 3 1/2"
* Hitch Ball Height	17 3/4"	17 3/4"	17 3/4"	17 3/4"
Hitch Weight (w/o options)	500#	680#	680#	730#
Fresh Water (gal.)	39	39	39	39
Grey Water (gal.)	39	39	39	37
Black Water (gal.)	23	23	33	39
Tire Size	ST205/75R14	ST205/75R14	ST205/75R14	ST225/75R15

### Tire inflation (PSI) cold

ST205/75R14 50 psi

ST225/75R15 50 psi

### Alignment

Toe In            0-1/8" - all models

Camber            0-1 1/2 degree positive - all models

### \* Hitch Ball Height

The proper height will vary according to the weight you carry and the tires you use. However, checking the height on your trailer is relatively easy:

1. With trailer on fairly level ground measure from ground to bottom of frame, front and rear.
2. Adjust front jack until measurements are equal.
3. Now measure from ground to the inside top of ball coupler. This figure is the hitch height. The hitch ball is then usually set 1/2" to 1" higher, according to the spring rate of your tow vehicle, to allow for it to settle when the trailer is hitched up.

# NOTES

## NOTES

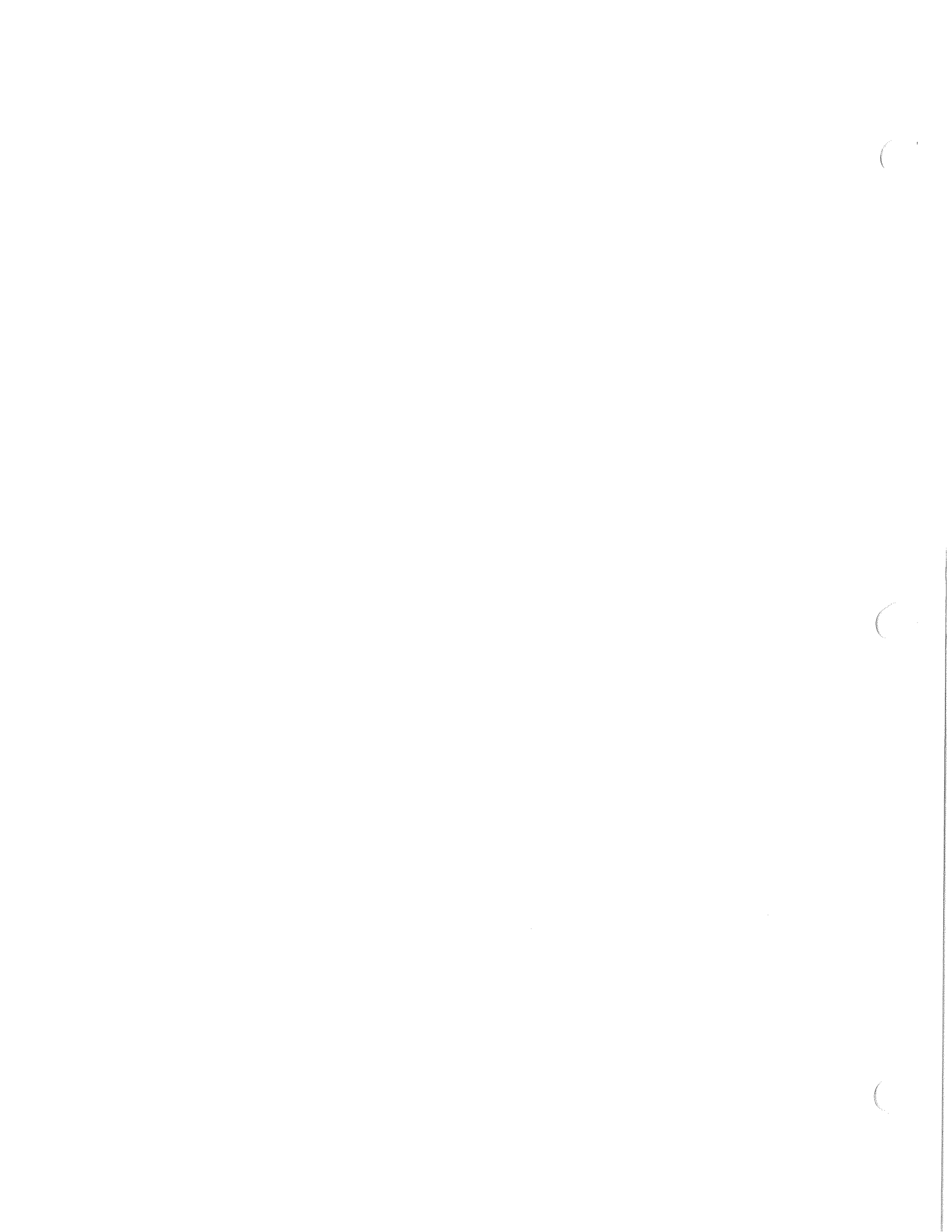

***AIRSTREAM, INC.***

P.O. Box 629  
419 West Pike Street  
Jackson Center, OH 45334-0629  
(937) 596-6111  
FAX: (937) 596-6092