

**MODELS**

G-106 T

G-110 T

G-110 M

G-117 M

G-130 M

**BOWEN**

*Gas*

**WATER HEATERS**

*Operating and service*  
**MANUAL**

**HATWOOD BOWEN CO.**

## GENERAL

Your new Bowen Gas Water Heater is simple to operate and is built to give long years of trouble-free performance. However, you will achieve maximum results if you will first take a few minutes time to read through this manual. The following operating and service suggestions will increase the utility value of your heater and better maintain its operating efficiency.

## PRINCIPLE OF OPERATION

A burning pilot flame playing on the tip of a pilot (thermocouple) actually generates a minute electrical current (15 to 30 millivolts). This tiny current is transmitted from the safety pilot to the thermostat valve through a wire leading from the pilot tip. The wire terminates in a small magnetic assembly "built into" the thermostat valve. When lighting the pilot (as described in operating instructions on pages 3 and 4) a plunger which incorporates the master valve seat and a metal disc is depressed manually to open the valve seat and simultaneously set the metal disc on the magnet. After the pilot has been burning for approximately one minute, the heat is sufficient to generate the current which flows to the magnet, the pilot current will hold the metal disc down and master valve seat open. Now by turning the dial to "ON" and setting the temperature dial to the desired temperature, the main gas burner will come on and automatically cycle the burner to maintain the temperature setting of the thermostat. The pilot now is holding the metal disc down and the master valve seat open, and gas is allowed to pass through the temperature dial and pilot adjustment seat. The thermostat now opens and closes by actuation from the element (rod extending into the tank and water) as the water is heated or becomes cool. Gas is being metered to the pilot through the pilot adjustment seat and the unit will, therefore, continue to operate automatically. If the pilot flame is extinguished, the thermocouple (pilot tip) will cool, stop generating its tiny electrical current, and the magnetic field will fail to hold the metal disc down and it will be released under the spring tension to close the master valve seat. The gas will now be totally shut off to both the burner and pilot. (Known as 100% shut off).



SEE INSTRUCTIONS FOR LIGHTING OR  
RELIGHTING EASY TO FOLLOW STEP BY  
STEP WITH ILLUSTRATIONS. PAGES 3 & 4

# YOUR BOWEN GAS WATER HEATER ("G" SERIES EXCEPT MODEL "G"-110T & "G"-106T)

IS EQUIPPED WITH EITHER A MAXITROL OR MINNEAPOLIS-HONEYWELL REGULATOR

If it is a Maxitrol regulator, follow instructions in service manual, page 7, paragraph 6 and 7 and refer to illustration on page 6.

If it is a Minneapolis-Honeywell regulator, follow instructions and refer to illustrations appearing on this page.

## ADJUSTMENTS

Adjust the outlet pressure as follows:

**BEFORE STARTING, TURN OFF THE GAS TO THE APPLIANCE MANIFOLD.**

1. Connect a properly-sized manometer or other accurate pressure gage at the test-gage tapping furnished by the appliance manufacturer downstream from all gas controls.

2. Turn on the gas and light the burner(s).

3. Unscrew and remove the regulator cap (V5172A and B) Fig. 2, or the changeover mechanism (V5172C), Fig. 3.

4. Turn the adjusting screw slowly until the manometer indicates the pressure required. (See paragraph 6, page 7 of Service Manual). Turn Clockwise to increase pressure; counterclockwise to decrease pressure.

5. Replace the cap or changeover mechanism, turn off the gas, disconnect the manometer, and plug the test-gage tapping.

### PRESSURE REGULATOR CONVERSION (V5172C only)

To change the regulator from LP to natural gas depress the regulator convertor with screwdriver and turn counterclockwise (Fig. 3). To change from natural to LP, depress and turn clockwise

NOTE: Be sure system is operating properly before leaving job.

### REGULATOR AS INSTALLED

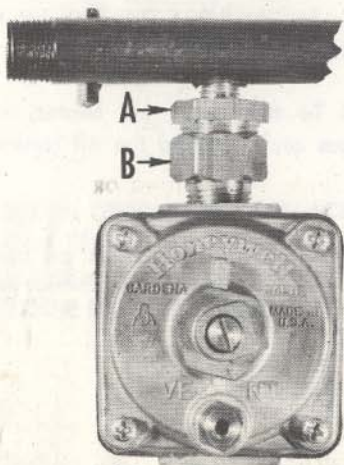
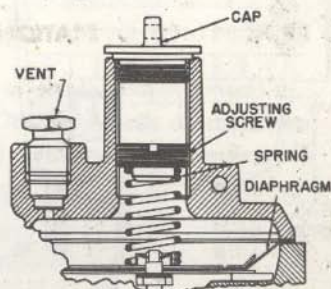
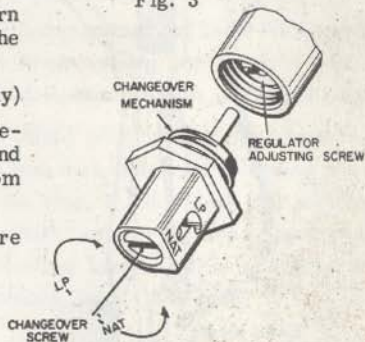

Fig. 2



Cross-Section of V5172A or B.

Fig. 3



Pressure Regulator Changeover (V5172C).

## ★ INSTRUCTIONS TO DISASSEMBLE ★

1. Hold half union **A** with wrench (Do not turn)
2. Turn **B** with wrench while holding **A** stationary. clockwise

OPERATING INSTRUCTIONS FOR UNITS EQUIPPED  
WITH MINNEAPOLIS-HONEYWELL CONTROLS

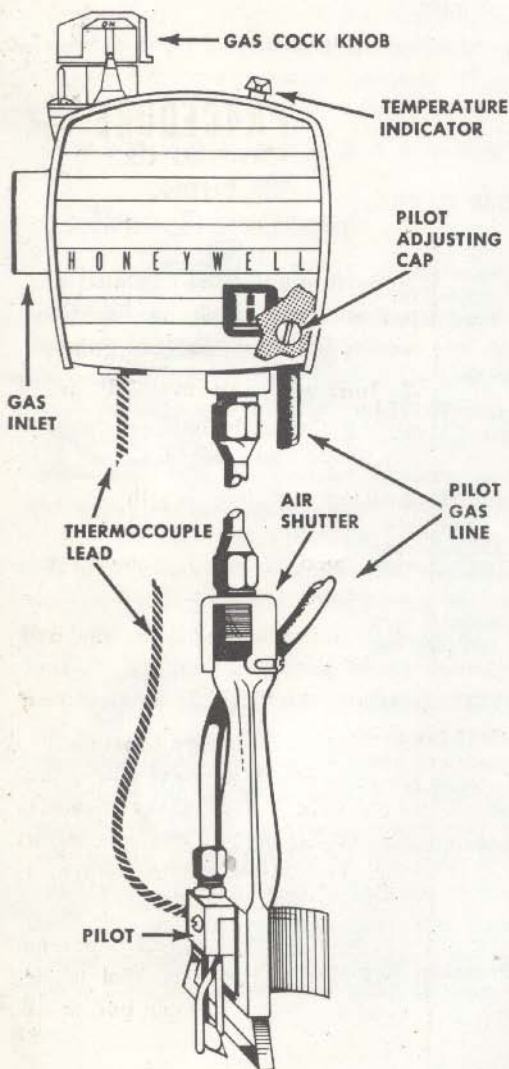

## PROCEDURE FOR LIGHTING OR RELIGHTING

- 1 Be sure the heater is filled with water and that all air has been vented from gas line. (See Page 5).
- 2 Turn gas cock knob to "Off" position and temperature indicator to lowest temperature position.
- 3 Wait sufficient length of time to allow gas which may have accumulated in burner compartment to escape. (Approximately 5 minutes).
- 4 Turn gas cock knob to pilot.
- 5 Depress the knob, light the pilot burner, and hold the knob down for about 1 minute.
- 6 Turn the gas cock knob to ON.
- 7 Set the lever indicator for the desired water temp.
- 8 To shut down the heater, turn gas cock knob to the off position.

FIGURE (2)

**NOTE:** For instructions on how to adjust pilot flame, see Figure 4, Page 5.

OPERATING INSTRUCTIONS FOR UNITS EQUIPPED  
WITH GENERAL CONTROLS

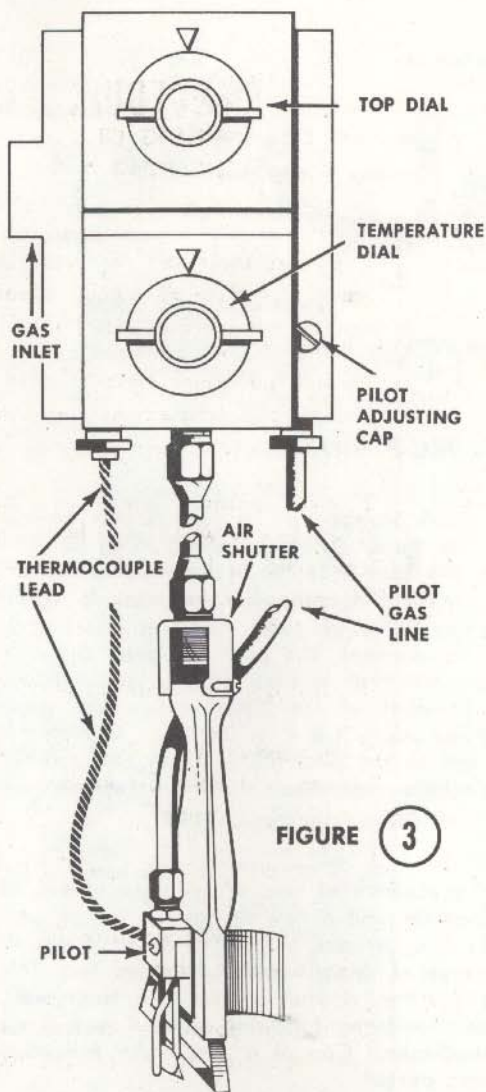

**PROCEDURE FOR  
LIGHTING OR  
RELIGHTING**

- 1 Be sure that heater is filled with water and that all air has been vented from gas line. (See Page 5).
- 2 Turn top dial to "Off" position, and temperature dial to lowest temperature position.
- 3 Wait sufficient length of time to allow gas which may have accumulated in burner compartment to escape. (Approx. 5 min.)
- 4 Turn top dial to "Light Pilot" and continue turning until dial "Stops." Hold in this position while lighting.
- 5 Allow pilot to burn approximately one minute before releasing dial from stop. If pilot does not remain ignited, repeat above operations allowing longer period before releasing from DIAL STOP.
- 6 Turn top dial to "On" position and turn temperature dial to desired position. The main burner will ignite.
- 7 To shut down heater, turn top dial to "Off."

**WHEN ORDERING REPLACEMENT  
CONTROLS BE SURE TO GIVE  
NAME AND MODEL NUMBER OF  
YOUR PRESENT CONTROL.**

**NOTE: For instructions on how  
to adjust pilot flame, see  
Figure 4, Page 5.**

## SERVICE INSTRUCTIONS

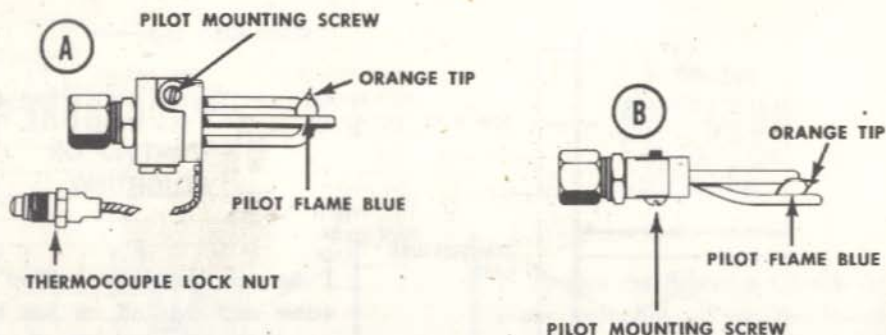

FIGURE

4

### GENERAL MC-3 PILOT

#### 1 PILOT FLAME ADJUSTMENT

If the pilot flame does not have a small orange tip the pilot is not getting enough gas. (See Figure 4-A above). The flame should be about  $\frac{1}{4}$  of an inch in vertical height when the water in the tank is cold and the burner is off and a flame  $\frac{1}{4}$  to  $\frac{3}{8}$  of an inch in horizontal length when the tank is warm. (See Figure 4-B above). A large orange flame indicates excessive gas supply resulting in short pilot life and early replacement. The pilot has been properly adjusted at the factory and should operate with a blue orange tipped flame enveloping the pilot thermocouple. Removal of the "pilot adjustment cap" will reveal the pilot adjustment screw. (See pages 3 & 4 for location). Turning this screw clock-wise reduces the flow of gas to the pilot (blue flame) and counter clock-wise the gas supply is increased (orange flame). Always replace the "pilot adjustment cap" to prevent gas leakage.

#### 2 GAS LINE VENTING

Most failures to light are caused by the absence of gas, or presence of air, at the pilot port. This usually happens when the unit is new or has run out of gas. Upon restoration of the gas supply, the line, or lines, are full of air. It is recommended that appliances such as the range or space heater be lighted first. This assures a supply of gas in the main gas line. If your control is a Honeywell, venting of the gas line may be accomplished by following steps 4 and 5 on page 3, for an extended period. The General Control is vented by following steps 4 and 5, page 4, for an extended period.

#### 3 AIR SHUTTER ADJUSTMENT

(See Figure 5-B). All fuels depend upon air (oxygen) to give them proper burning characteristics. This water heater is required to burn varying types of gases and consequently the air requirements vary. A yellow smoking flame indicates a lack of air and a noisy hard blue flame indicates an excess of air. The air shutter is rotated around the main burner orifice holder and is held in place by a small shutter adjustment screw. Loosen the screw for adjustment.

A good method of adjusting the air shutter is to rotate the shutter closed far enough for yellow tipping to occur on the main burner, (not pilot) and then slowly open the air shutter until all signs of yellow tipping are gone. When proper adjustment has been obtained, tighten screw holding air shutter.

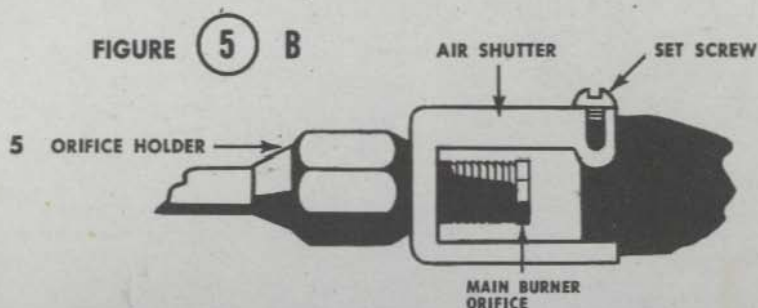

- 4 BURNER & PILOT ASSEMBLY REMOVAL IN CASE OF CLEANING OR REPLACEMENT**
- A.** It is conceivable that upon removal of the burner and pilot assembly, damage could mis-align the component parts. Such malalignment could easily render the unit inoperative or unstable. Care should always be taken to handle these parts with extreme care.
- B.** Remove lower panel by turning the slot headed nuts one-half turn.

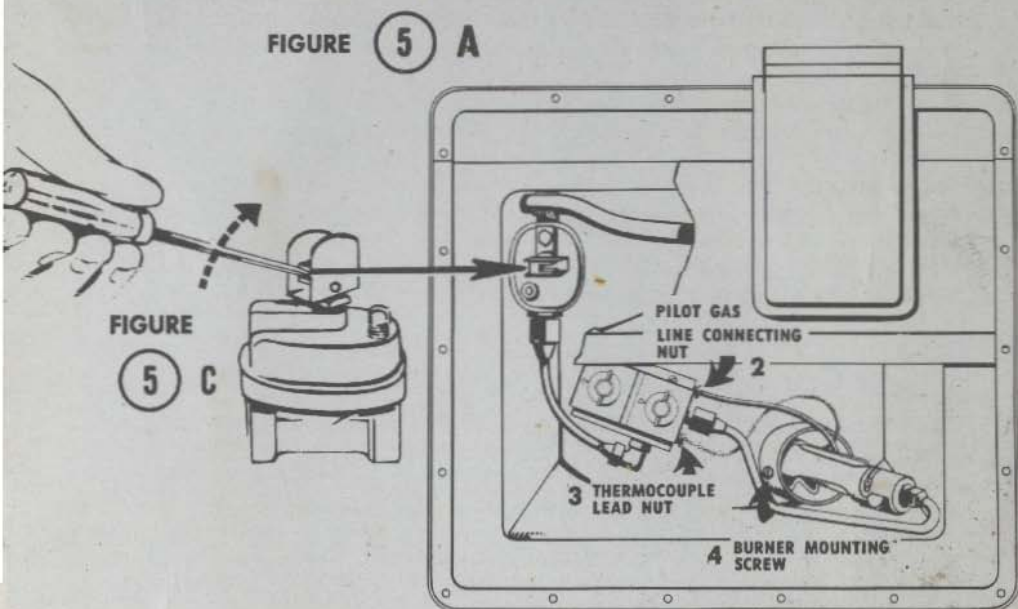

- C.** Turn off the gas supply.
- D.** With a wrench, unscrew the pilot (#2) and thermocouple (#3) nuts where they are joined to the thermostat. (See Figure 5-A). (Do not remove gas tube at the pilot).

